

Large-Type Edition

The University of the State of New York

REGENTS HIGH SCHOOL EXAMINATION

PHYSICAL SETTING
EARTH SCIENCE

Friday, January 24, 2020 — 9:15 a.m. to 12:15 p.m., only

The possession or use of any communications device is strictly prohibited when taking this examination. If you have or use any communications device, no matter how briefly, your examination will be invalidated and no score will be calculated for you.

Use your knowledge of Earth science to answer all questions in this examination. Before you begin this examination, you must be provided with the *2011 Edition Reference Tables for Physical Setting/Earth Science*. You will need these reference tables to answer some of the questions.

You are to answer all questions in all parts of this examination. You may use scrap paper to work out the answers to the questions, but be sure to record your answers on your answer sheet and in your answer booklet. A separate answer sheet for Part A and Part B–1 has been provided to you. Follow the instructions from the proctor for completing the student information on your answer sheet. Record your answers to the Part A and Part B–1 multiple-choice questions on this separate answer sheet. Record your answers for the questions in Part B–2 and Part C in your separate answer booklet. Be sure to fill in the heading on the front of your answer booklet.

All answers in your answer booklet should be written in pen, except for graphs and drawings, which should be done in pencil.

When you have completed the examination, you must sign the declaration printed on your separate answer sheet, indicating that you had no unlawful knowledge of the questions or answers prior to the examination and that you have neither given nor received assistance in answering any of the questions during the examination. Your answer sheet and answer booklet cannot be accepted if you fail to sign this declaration.

Notice ...

A four-function or scientific calculator and a copy of the *2011 Edition Reference Tables for Physical Setting/Earth Science* must be available for you to use while taking this examination.

DO NOT START THIS EXAMINATION UNTIL THE SIGNAL IS GIVEN.

Part A

Answer all questions in this part.

Directions (1–35): For each statement or question, choose the word or expression that, of those given, best completes the statement or answers the question. Some questions may require the use of the 2011 Edition Reference Tables for Physical Setting/Earth Science. Record your answers on your separate answer sheet.

1 What are two pieces of evidence that support the Big Bang Theory?

- (1) red shift of light and cosmic background radiation
- (2) red shift of light and the different shapes of galaxies
- (3) planetary motion and cosmic background radiation
- (4) planetary motion and the different shapes of galaxies

2 The diagram below compares the relative diameters of two planets in our solar system.

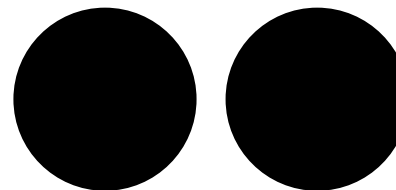

Which two planets have diameters that most closely resemble this comparison?

- (1) Uranus and Neptune
- (2) Jupiter and Saturn
- (3) Earth and Mars
- (4) Mercury and Venus

3 The motion of a Foucault pendulum provides evidence that Earth

- (1) varies in distance from the Sun
- (2) spins on its axis
- (3) is tilted on its axis
- (4) travels around the Sun

4 Which factor is a primary cause of seasonal changes on Earth?

- (1) change in Earth's distance from the Sun
- (2) change in the rate of Earth's rotation
- (3) wobble of Earth's axis
- (4) tilt of Earth's axis

5 The diagram below represents the location of gyres in the Pacific Ocean. A gyre is a circular pattern of flowing ocean currents.

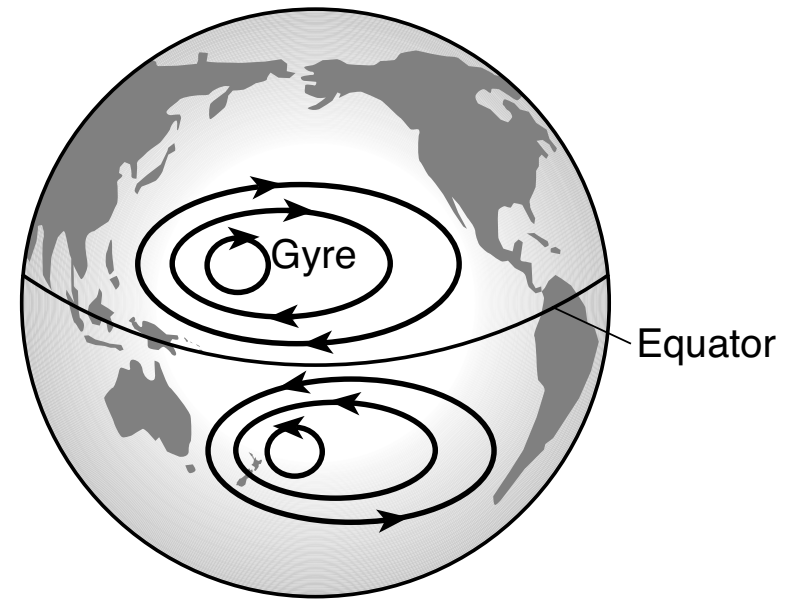

Planet Earth, Understanding Science and Nature, Time Life Inc.

The clockwise direction of flow of these currents in the Northern Hemisphere, and the counterclockwise direction of flow in the Southern Hemisphere are the result of

- (1) the Coriolis effect
- (2) the Doppler effect
- (3) Earth's magnetism
- (4) the Moon's magnetism

6 Which changes in surface water movement are likely to occur when vegetation is removed from the side of a hill?

- (1) infiltration decreases and runoff decreases
- (2) infiltration decreases and runoff increases
- (3) infiltration increases and runoff decreases
- (4) infiltration increases and runoff increases

7 During which phase change will two grams of water release 668 joules of heat energy?

- (1) melting
- (2) freezing
- (3) vaporization
- (4) condensation

8 The chart below describes some components of the solar system.

Object	Description
X	chunk of rock and ice orbiting from the outer solar system to near the Sun
Y	streak of light seen when a space rock enters Earth's atmosphere and starts burning up
Z	rocky/metallic object orbiting the Sun between Mars and Jupiter

Letters X, Y, and Z identify which components of our solar system?

- (1) X = asteroid; Y = meteor; Z = comet
- (2) X = asteroid; Y = meteor; Z = moon
- (3) X = comet; Y = meteor; Z = asteroid
- (4) X = comet; Y = moon; Z = meteor

9 The time-exposure photograph shown below was taken by an observer in the Northern Hemisphere to record the apparent paths of stars.

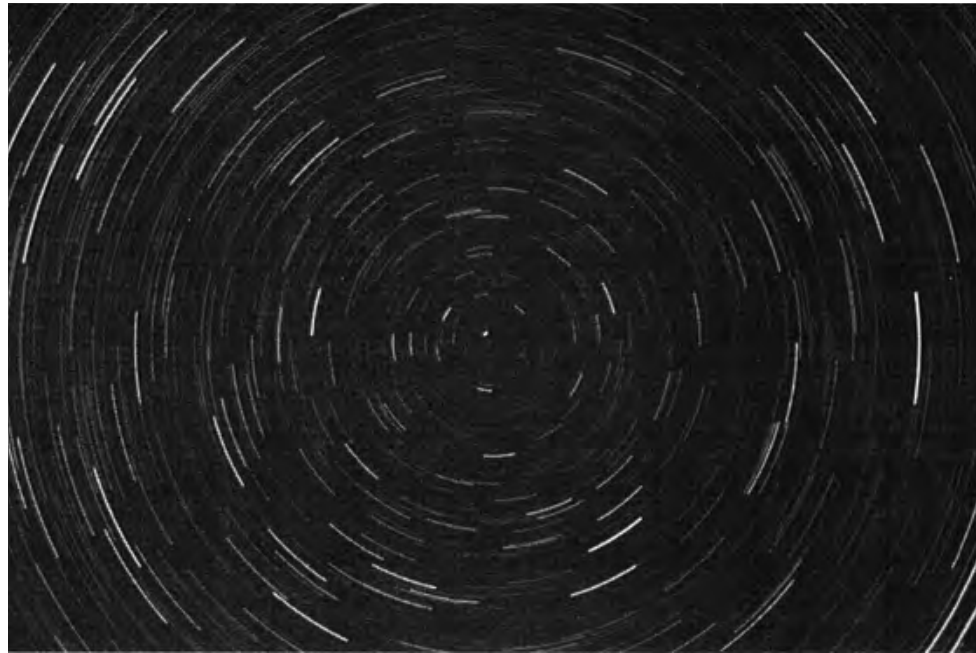

<http://dianajuncher.dk/>

The name of the bright star near the center that the other stars appear to be circling is

(1) *Polaris*

(2) *Alpha Centauri*

(3) *Betelgeuse*

(4) *Deneb*

10 The map below shows the average annual snowfall, in inches, for western New York State.

Average Season Snowfall in Inches

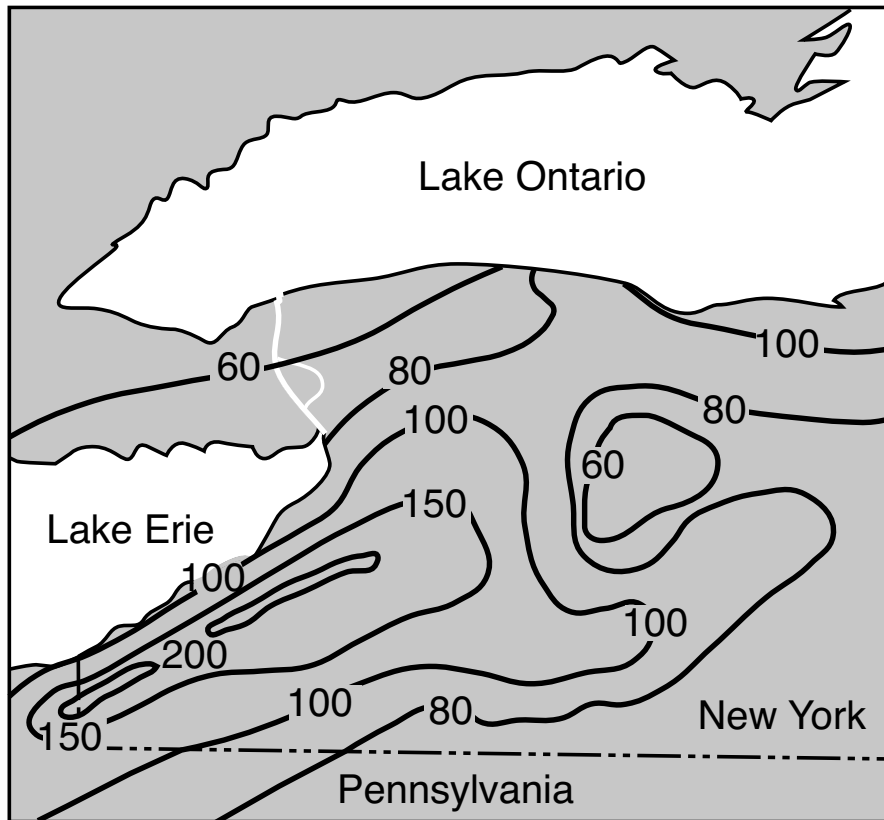

According to the map, which of these cities receives the greatest average annual snowfall?

- (1) Buffalo
- (2) Jamestown
- (3) Niagara Falls
- (4) Elmira

11 Which current has a warming effect on the climate of the southeast coast of Africa?

- (1) Guinea Current
- (2) Falkland Current
- (3) Benguela Current
- (4) Agulhas Current

12 Geologic history is divided into eras, periods, and epochs based on the

- (1) type of rock deposited at different times throughout history
- (2) half-life of radioactive isotopes found in rocks
- (3) inferred movements of Earth's landmasses
- (4) fossil evidence found in bedrock

- 13 The map below shows two locations, labeled *A* and *B*, separated by a mountain range. The locations are at the same elevation. The arrow represents the direction of prevailing winds.

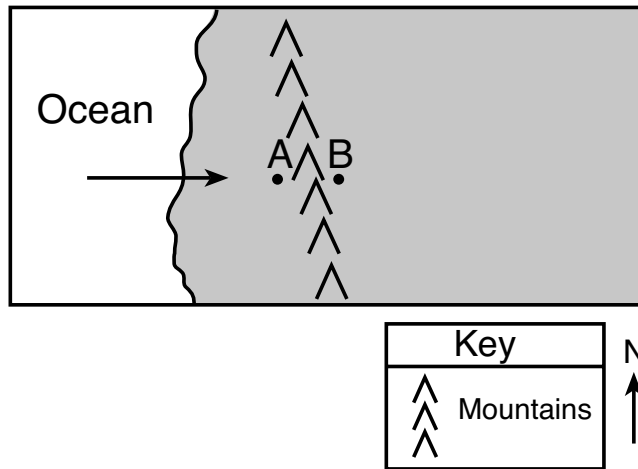

Compared to the climate at location *A*, the climate at location *B* is most likely

- (1) warmer and drier (3) cooler and drier
(2) warmer and wetter (4) cooler and wetter

- 14 Which important geologic event in New York State occurred just after the Grenville Mountains were starting to erode?
- (1) Pangaea began to break up.
(2) The Iapetus Ocean began to open.
(3) The Catskill Delta formed.
(4) The Taconic Mountains were eroded.
- 15 Scientists infer that oxygen first began to enter Earth's atmosphere after the appearance of
- (1) the earliest grasses
(2) the earliest flowering plants
(3) coal-forming forests
(4) oceanic cyanobacteria
- 16 Which mantle hot spot is correctly matched to its overlying tectonic plate?
- (1) Tasman Hot Spot–Pacific Plate
(2) Canary Island Hot Spot–Eurasian Plate
(3) St. Helena Hot Spot–South American Plate
(4) Yellowstone Hot Spot–North American Plate

17 The weather map below shows air-pressure readings given in millibars. Points A, B, C, and D are locations on Earth's surface.

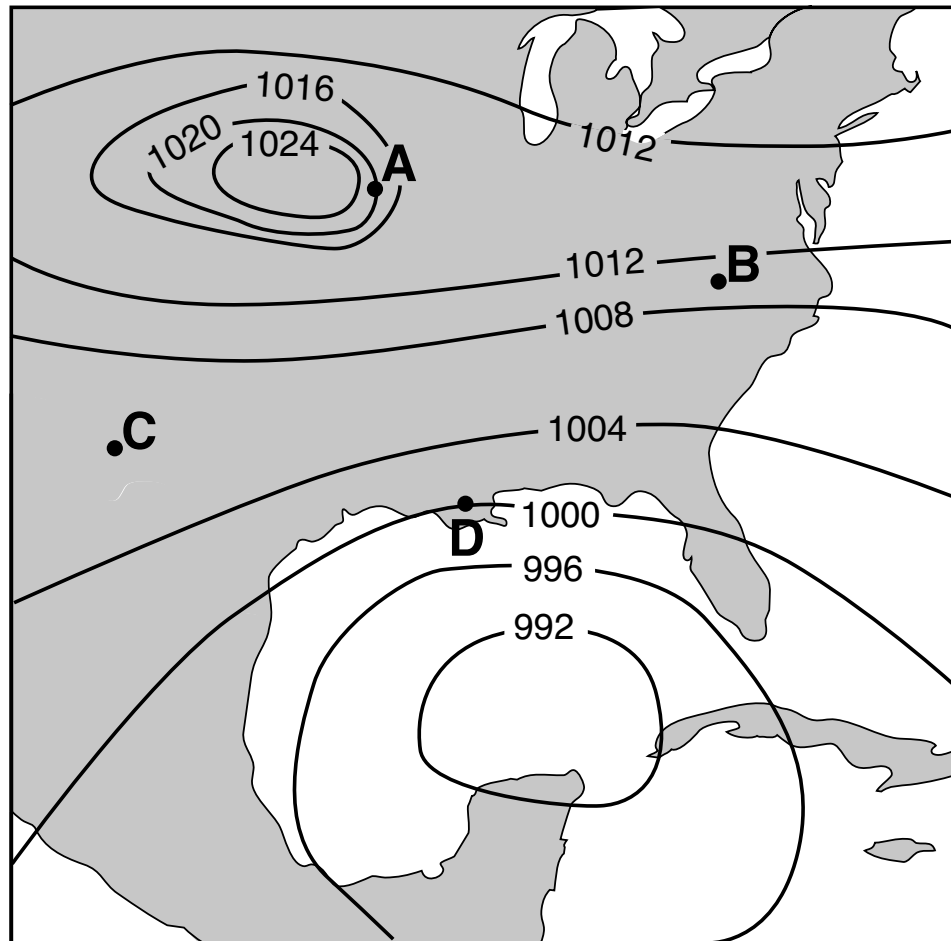

At which location is surface wind speed the *lowest*?

- (1) A
- (2) B
- (3) C
- (4) D

18 The diagram below shows a weather instrument used to determine relative humidity.

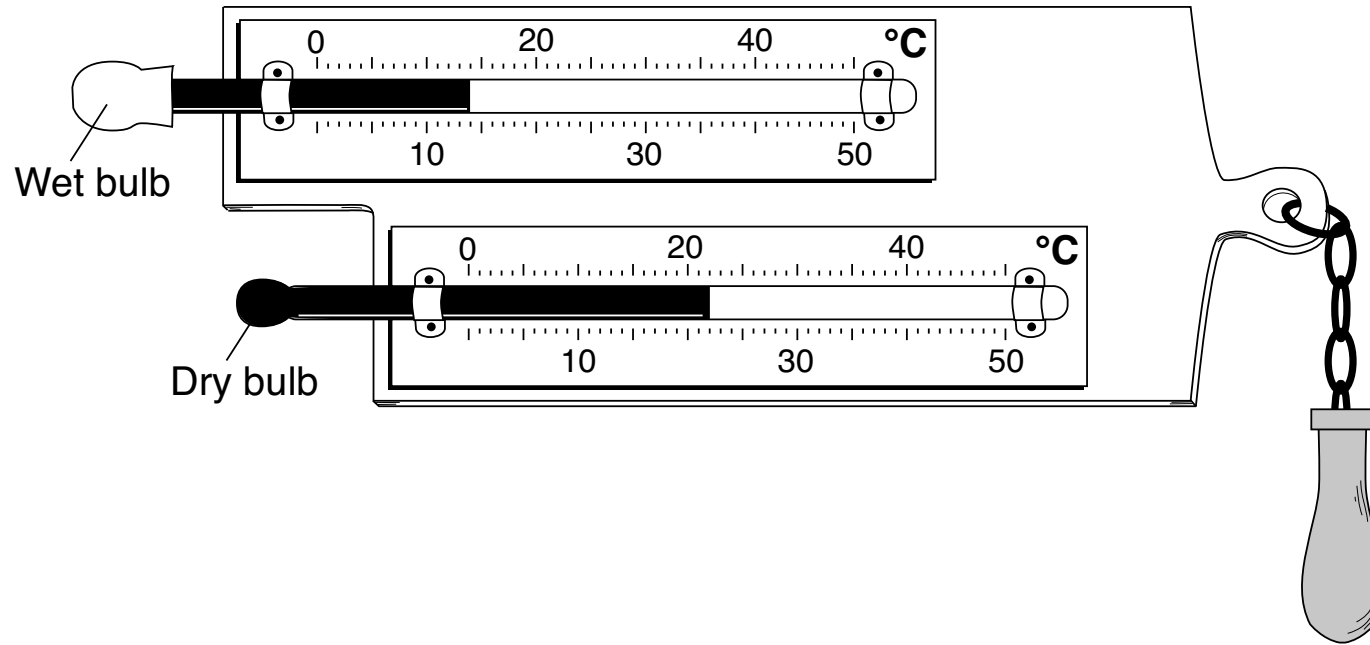

What is the relative humidity?

- (1) 40%
- (2) 36%
- (3) 8%
- (4) 4%

19 The diagram below shows the locations of the two major jet streams in Earth's atmosphere.

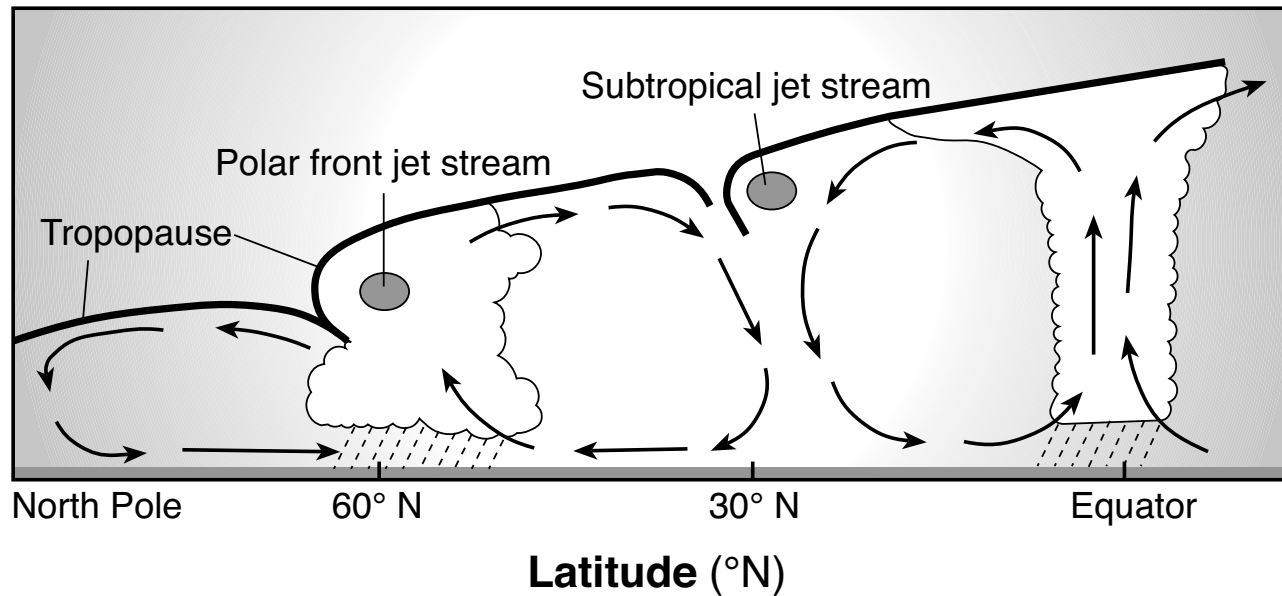

Compared to the subtropical jet stream, the polar front jet stream is at a

- (1) lower latitude and lower altitude
- (2) lower latitude and higher altitude
- (3) higher latitude and lower altitude
- (4) higher latitude and higher altitude

20 The graph below shows the average global temperature changes before and after Mount Pinatubo's eruption in the Philippines. Sulfur from volcanic eruptions, like Mount Pinatubo's, forms sulfuric acid particles in the upper atmosphere.

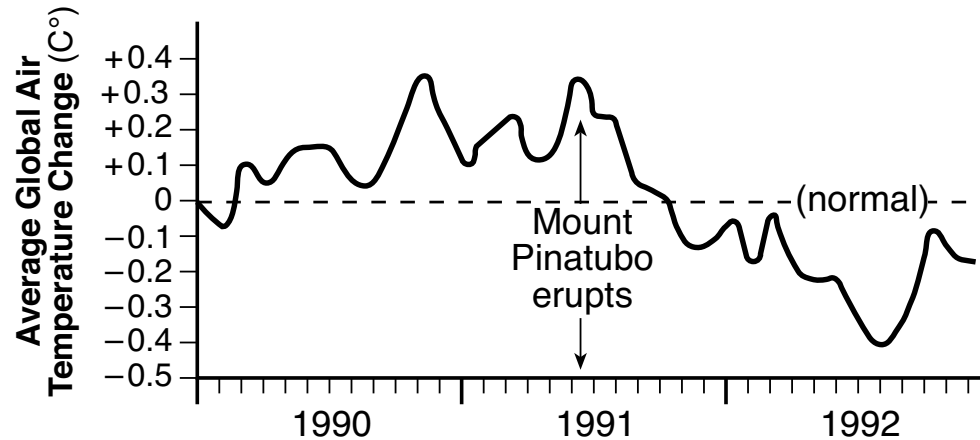

Adapted from: Aherns, C. Donald, *Essentials of Meteorology: An Invitation to the Atmosphere*

According to the graph, these atmospheric particles appear to have caused global air temperatures to

- (1) generally decrease for one year
- (2) decrease, but then increase to normal levels in one year
- (3) generally increase for one year
- (4) increase, but then decrease to normal levels in one year

21 The map below shows the location of the Chicxulub crater, which was formed when a massive asteroid impacted Earth 65.5 million years ago.

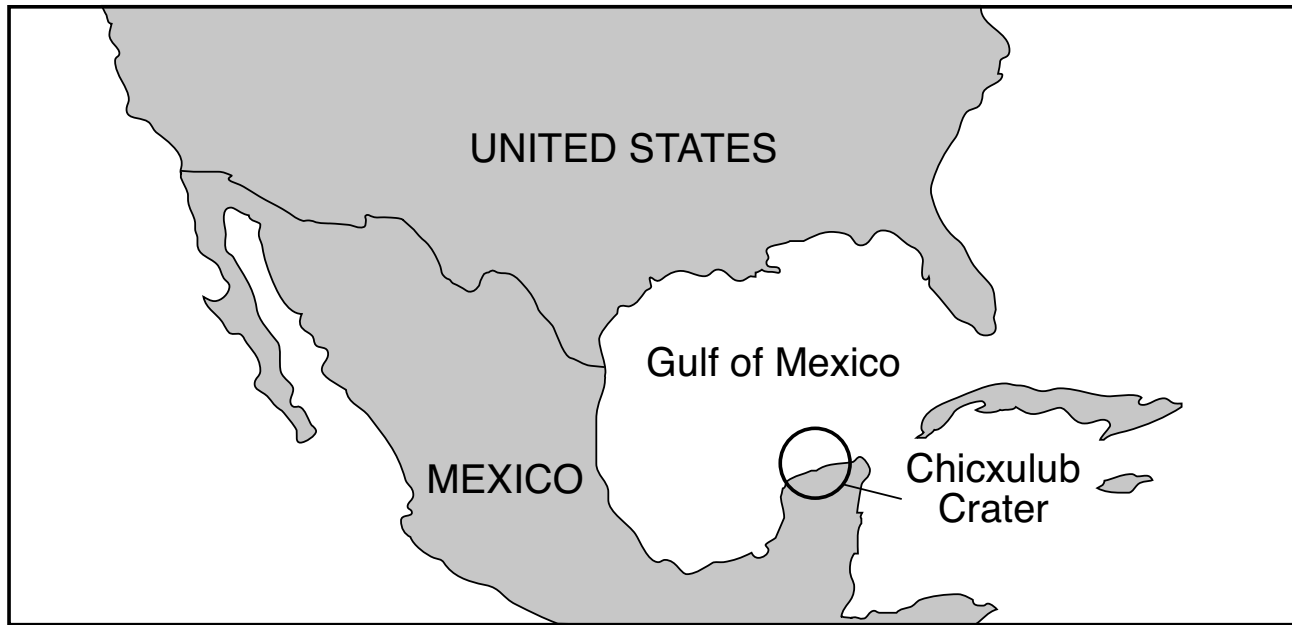

Scientists infer that this impact contributed to the extinction of

- (1) trilobites
- (2) gastropods
- (3) many land plants
- (4) placoderm fish

22 The cross section below represents the boundaries of the Pacific Plate, the Juan de Fuca Plate, and the North American Plate. The numbers show the age of the sea floor, in millions of years, at locations on the Pacific Plate. Letter X represents a location on the ocean floor surface.

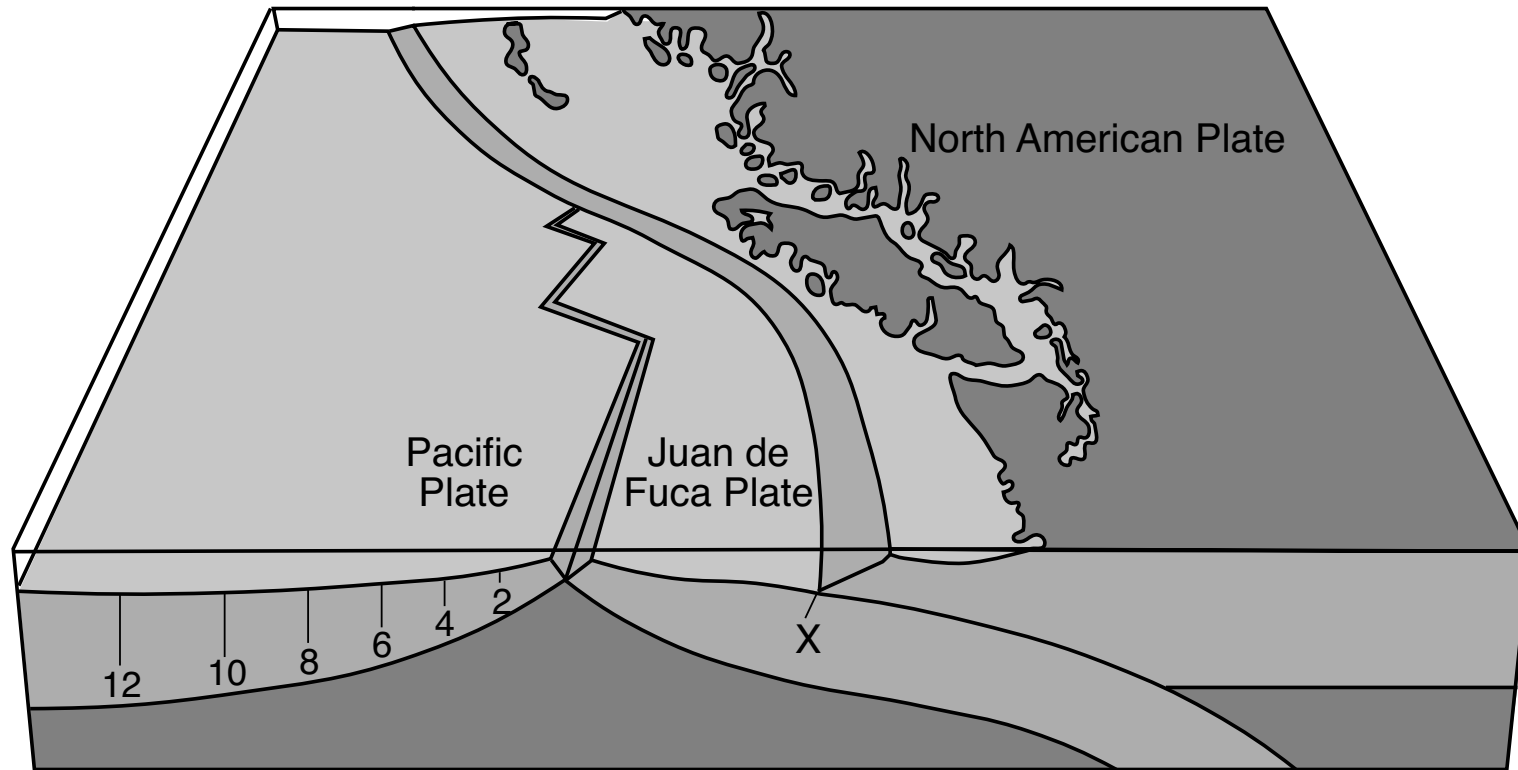

Adapted from: <http://mountainculturegroup.com/>

What is the most probable age of the ocean floor at location X, if the Pacific Plate and the Juan de Fuca Plate are moving at the same rate?

- (1) 10 million years
- (2) 8 million years
- (3) 6 million years
- (4) 4 million years

23 A cross section of Earth's crust is represented below. Index fossils are present in some of the rock layers.

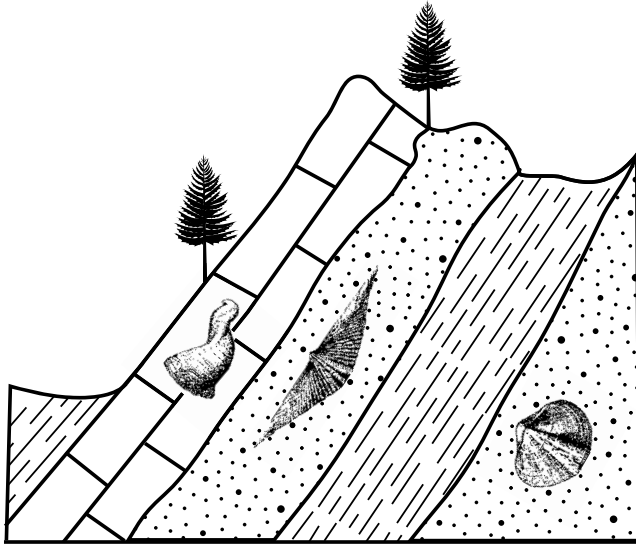

These rock layers indicate evidence of past crustal movement based on the principle of

- (1) down-warping
- (2) crosscutting
- (3) original horizontality
- (4) contact metamorphism

24 The map below shows the continent of Australia. Letters *A* and *B* indicate locations on Earth's crustal surface.

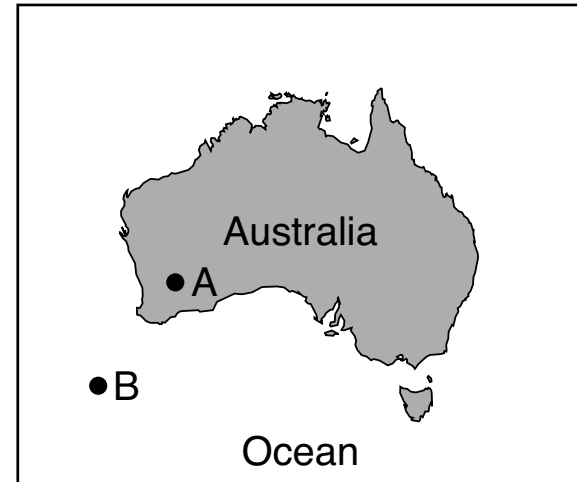

Compared to the crust at *A*, the crust at *B* is

- (1) thinner and less dense
- (2) thinner and more dense
- (3) thicker and less dense
- (4) thicker and more dense

25 Why are *P*-waves received, but *S*-waves are *not* received by seismic stations located on the opposite side of Earth from an earthquake epicenter?

- (1) *S*-waves travel slower than *P*-waves.
- (2) *S*-waves travel faster than *P*-waves.
- (3) Earth's inner core absorbs *S*-waves.
- (4) Earth's outer core absorbs *S*-waves.

26 The Tug Hill region of New York State is geologically classified as a plateau because this region has relatively

- (1) high elevation and deformed bedrock
- (2) low elevation and deformed bedrock
- (3) high elevation and horizontal bedrock
- (4) low elevation and horizontal bedrock

27 What is the approximate minimum stream velocity required to transport the smallest particles of sand?

- (1) 1.0 cm/s
- (2) 0.7 cm/s
- (3) 0.3 cm/s
- (4) 0.1 cm/s

28 Which agent of erosion is primarily responsible for the formation of the barrier islands along the south shoreline of Long Island, New York?

- (1) wave action
- (2) wind
- (3) glacial ice
- (4) mass movement

29 A glacial moraine is best described as

- (1) unsorted sediment directly deposited by a glacier
- (2) sorted sediment deposited as the glacier melts
- (3) a body of water formed by a retreating glacier
- (4) an elongated hill composed of sand and formed by a retreating glacier

30 Which medium-grain-sized metamorphic rock is composed mostly of the same mineral as the sedimentary rock limestone?

- (1) gneiss
- (2) marble
- (3) quartzite
- (4) schist

31 Which diagram below best represents the surface features developed in a humid climate?

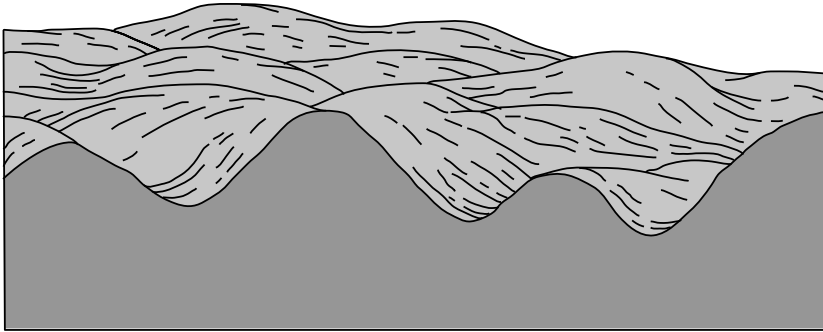

(1)

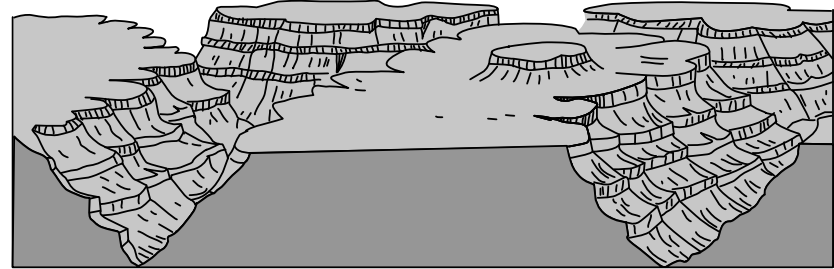

(3)

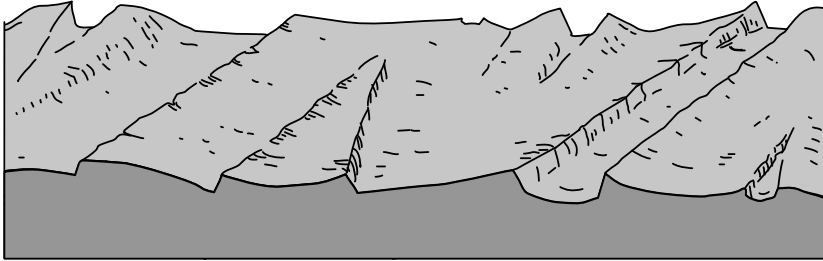

(2)

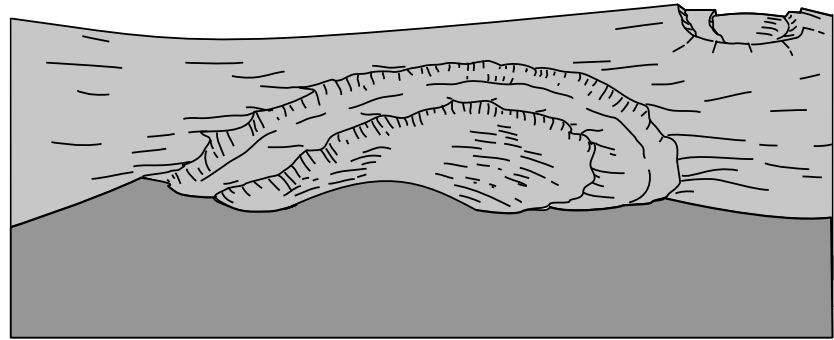

(4)

32 The block diagram below represents a section of a meandering stream. The arrows show the direction of stream flow.

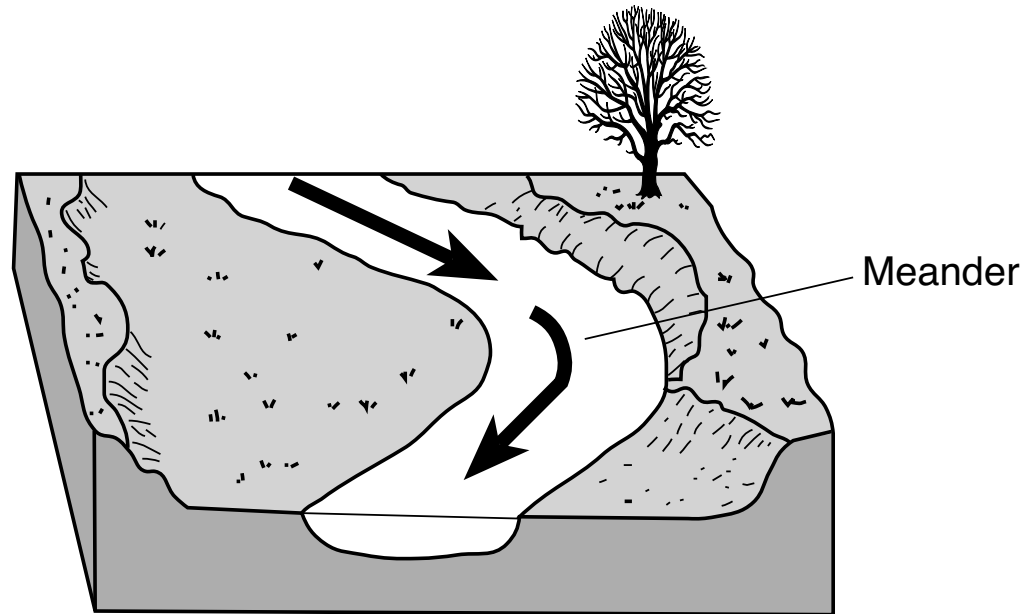

The streambank on the outside of this meander is steeper than the streambank on the inside of this meander because the water on the outside of this meander is moving

- (1) slower, causing more deposition
- (2) slower, causing more erosion
- (3) faster, causing more deposition
- (4) faster, causing more erosion

33 What is the texture of an igneous rock formed from magma that cooled slowly deep underground?

- (1) nonvesicular and coarse
- (2) nonvesicular and glassy
- (3) vesicular and fine
- (4) vesicular and very coarse

34 The photograph below shows a portion of a roadway in the mountains that was destroyed due to a landslide.



<http://fijisun.com.fj>

Which two factors most likely caused this landslide?

- | | |
|---|--|
| (1) wind action and meandering streams | (3) gravity and sand blasting of bedrock |
| (2) wind action and movement of glacial ice | (4) gravity and saturated soil |

35 The two photographs below and the arrow between them show conglomerate and the processes that changed the conglomerate to rock X.

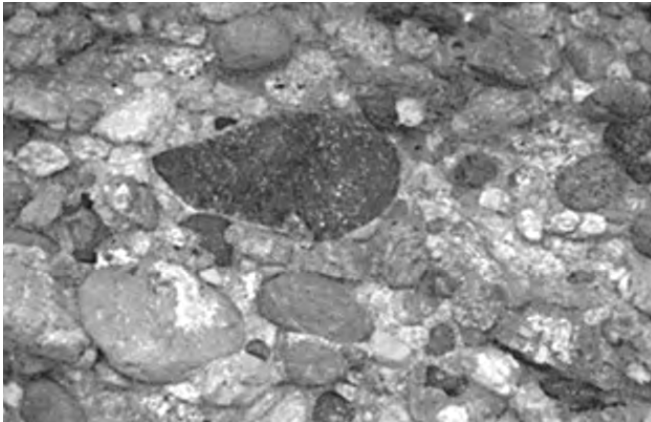

Conglomerate

→
Heat
and
pressure

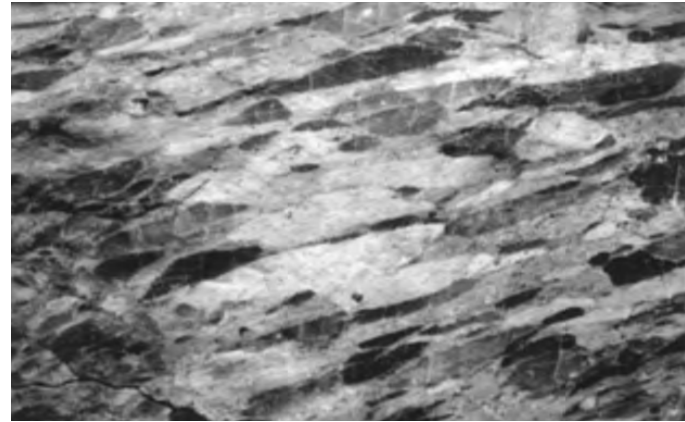

Rock X

Rock X is most likely

- (1) breccia
- (2) slate

- (3) metaconglomerate
 - (4) vesicular basalt
-

Part B-1

Answer all questions in this part.

Directions (36–50): For each statement or question, choose the word or expression that, of those given, best completes the statement or answers the question. Some questions may require the use of the 2011 Edition Reference Tables for Physical Setting/Earth Science. Record your answers on your separate answer sheet.

GO RIGHT ON TO THE NEXT PAGE ⇨

Base your answers to questions 36 through 38 on the passage and mineral table below and on your knowledge of Earth science. The table shows some properties of four minerals that display fluorescence.

Fluorescent Minerals

All minerals have the ability to reflect visible light. Only about 15% of minerals have an interesting physical property known as fluorescence. These minerals have the ability to temporarily absorb a small amount of electromagnetic energy and, an instant later, release a small amount of energy of a different wavelength. This change in wavelength causes a temporary color change of the mineral in the eye of an observer. The color change of fluorescent minerals is most spectacular when the minerals are placed in darkness and exposed to electromagnetic energy shorter than visible light.

A former zinc mine in New Jersey is one of the most famous sources of fluorescent minerals in the entire world. Zincite and willemite were two of the zinc ores mined there. It was later discovered that more than 91 minerals in this region displayed fluorescence under shortwave electromagnetic energy.

Mineral	Hardness	Color Under Visible Light	“Fluorescent” Color	Composition
Calcite	3	clear-white-variable	bright orange	CaCO ₃
Celestine	3 to 3.5	colorless-variable	yellow and/or white/blue	SrSO ₄
Willemite	5.5	pink-tan	bright green	Zn ₂ SiO ₄
Zincite	4	yellow-orange	yellow	ZnO

36 Which two forms of electromagnetic energy are used to produce the most spectacular fluorescence when placed in darkness?

- (1) microwaves and x rays
- (2) microwaves and infrared
- (3) ultraviolet and x rays
- (4) ultraviolet and infrared

37 Which two minerals can have the same fluorescent color?

- (1) calcite and celestine
- (2) calcite and zincite
- (3) celestine and willemite
- (4) celestine and zincite

38 The mineral zincite will scratch

- (1) calcite, but will not scratch celestine and willemite
 - (2) willemite, but will not scratch calcite and celestine
 - (3) calcite and celestine, but will not scratch willemite
 - (4) willemite and celestine, but will not scratch calcite
-

Base your answers to questions 39 and 40 on the diagram below and on your knowledge of Earth science. The diagram represents the lines of latitude and longitude on Earth. Points A through E represent locations on Earth.

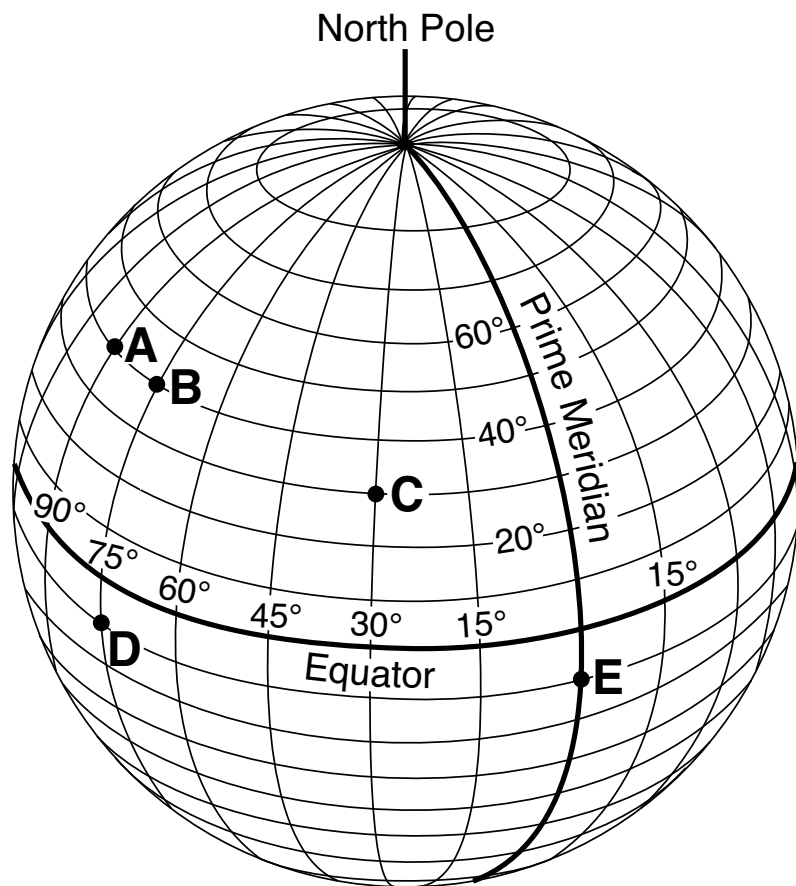

39 Which two locations have the same solar time?

- (1) A and B
- (2) B and D

- (3) C and E
- (4) D and E

40 From which location would an observer *never* see *Polaris* in the nighttime sky?

- (1) A
- (2) B

- (3) C
- (4) D

Base your answers to questions 41 through 43 on the diagram below and on your knowledge of Earth science. The diagram represents the inferred origin and evolution of most stars.

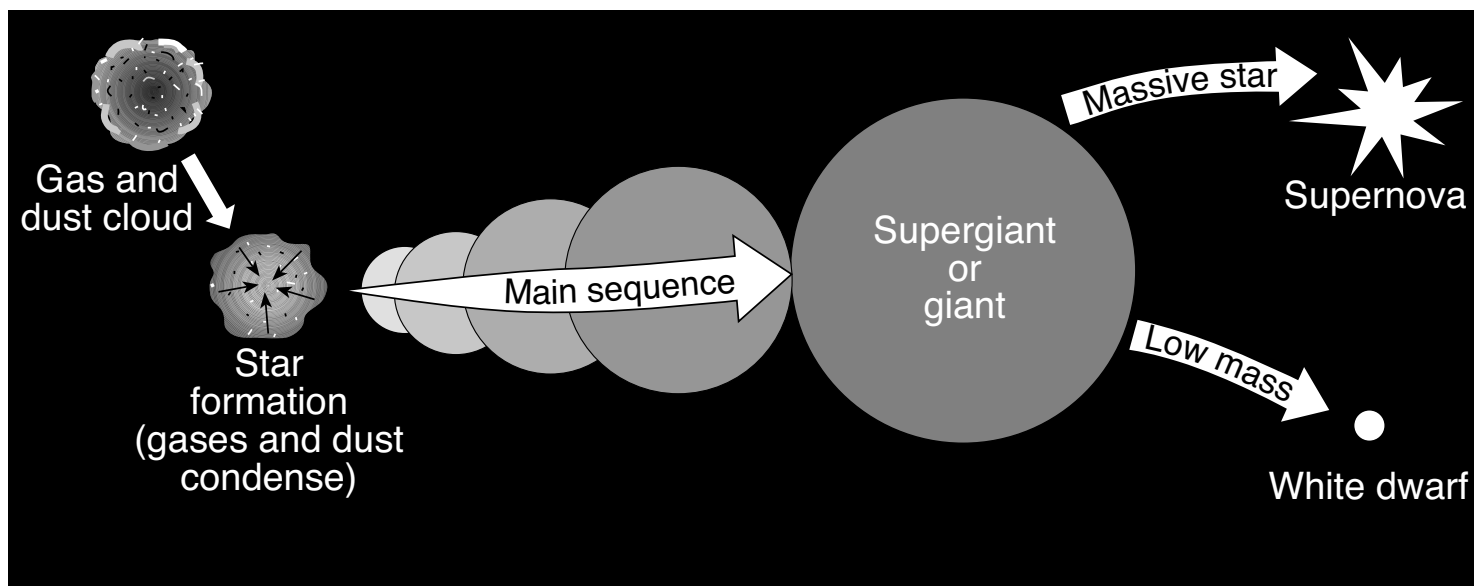

41 What causes the gas and dust cloud to condense and become a star?

- (1) density
- (2) friction
- (3) gravity
- (4) outgassing

42 Which star is most likely to become a supernova?

- (1) Sun
- (2) *Deneb*
- (3) *Pollux*
- (4) *Barnard's Star*

43 Which process produces large amounts of energy in a star by combining lighter elements into a heavier element?

- (1) convection
- (2) radiation
- (3) radioactive decay
- (4) nuclear fusion

Base your answers to questions 44 and 45 on the table below and on your knowledge of Earth science. The table shows the disintegration products and half-lives of five commonly used radioactive isotopes.

Radioactive Decay Data

Radioactive Isotope	Disintegration	Half-Life (years)
Carbon-14	$^{14}\text{C} \longrightarrow ^{14}\text{N}$	5.7×10^3
Potassium-40	$^{40}\text{K} \begin{cases} \longrightarrow ^{40}\text{Ar} \\ \longrightarrow ^{40}\text{Ca} \end{cases}$	1.3×10^9
Uranium-235	$^{235}\text{U} \longrightarrow ^{207}\text{Pb}$	7.1×10^8
Uranium-238	$^{238}\text{U} \longrightarrow ^{206}\text{Pb}$	4.5×10^9
Rubidium-87	$^{87}\text{Rb} \longrightarrow ^{87}\text{Sr}$	4.9×10^{10}

44 Which radioactive isotope takes the greatest amount of time to disintegrate?

- (1) potassium-40
- (2) uranium-235

- (3) uranium-238
- (4) rubidium-87

45 Which graph below represents the amount of potassium-40 and the amount of argon-40 and calcium-40 over four half-lives?

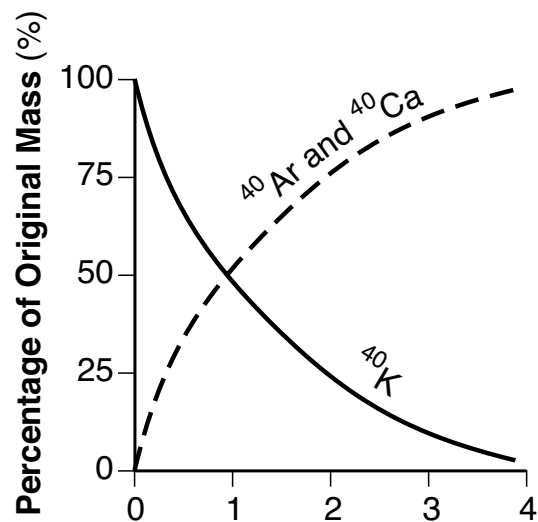

(1)

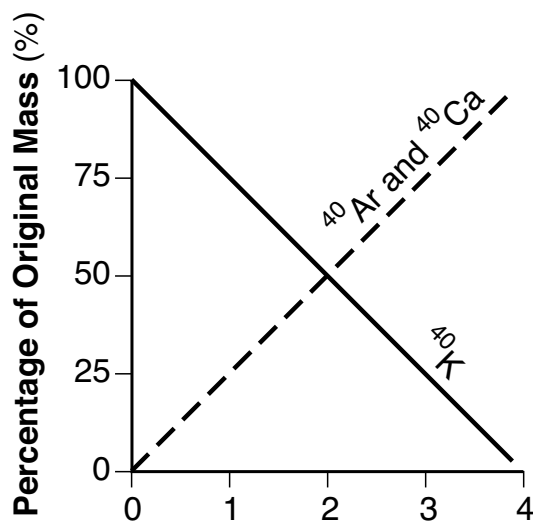

(3)

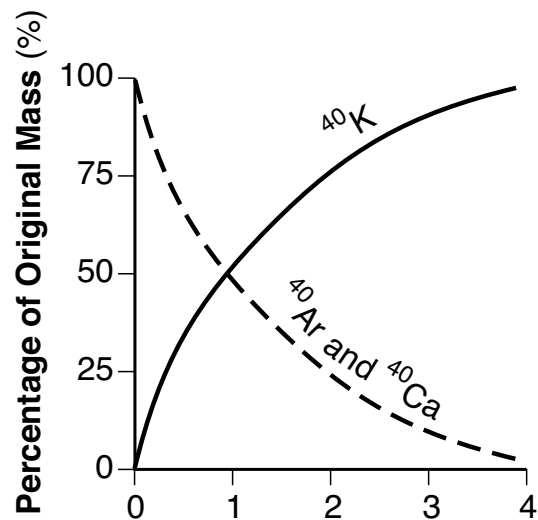

(2)

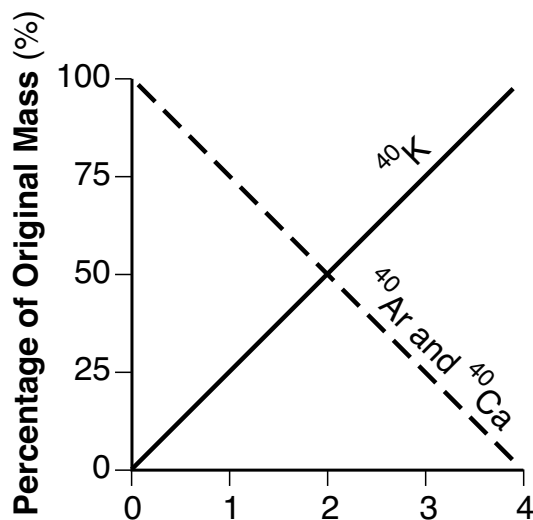

(4)

Base your answers to questions 46 through 48 on the cross section below and on your knowledge of Earth science. The arrows on the cross section represent the air movement along a weather front between two different air masses. The air masses are labeled.

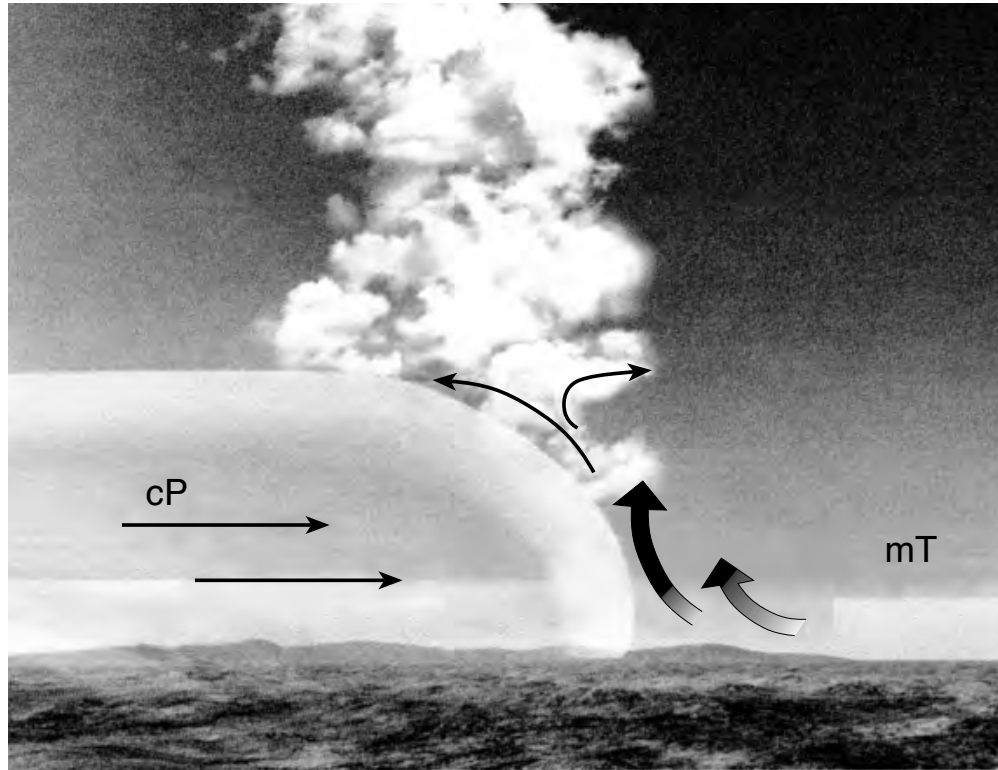

46 Which type of front is represented by this cross section?

- (1) warm
- (2) cold

- (3) stationary
- (4) occluded

47 Clouds are forming along the front because the rising air is

- (1) contracting and warming, causing evaporation
- (2) contracting and cooling, causing evaporation
- (3) expanding and warming, causing condensation
- (4) expanding and cooling, causing condensation

48 Which statement best describes the difference in air temperature and humidity between the cP and mT air masses?

- (1) The mT air mass is warmer and more humid.
 - (2) The mT air mass is cooler and less humid.
 - (3) The cP air mass is warmer and less humid.
 - (4) The cP air mass is cooler and more humid.
-

Base your answers to questions 49 and 50 on the diagram below and on your knowledge of Earth science. The diagram represents twelve positions of Earth in its orbit around the Sun and twelve constellations that can be seen in the midnight sky by an observer looking south in New York State at different times of the year. The approximate locations of the constellations in relation to Earth's orbit are shown.

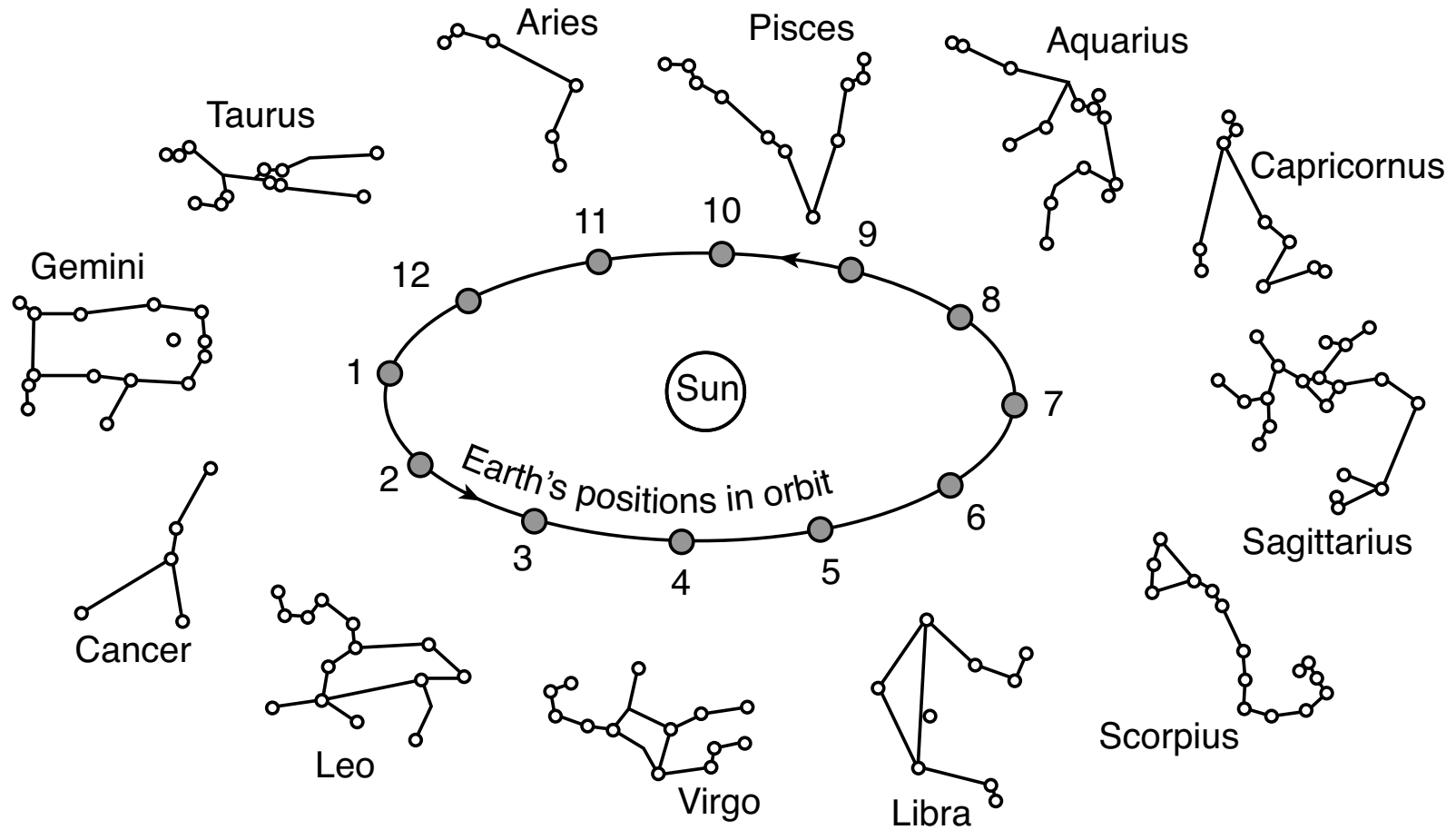

(Not drawn to scale)

- 49 Which motion causes observers on Earth to see different constellations at different times of the year?
- (1) Earth revolves around the constellations.
 - (2) Earth revolves around the Sun.
 - (3) The constellations revolve around Earth.
 - (4) The constellations revolve around the Sun.
- 50 At position 5, an observer on Earth sees a full Moon (the fully lighted side of the Moon) at midnight. At this time, the full Moon would appear closest to the constellation
- (1) Aries
 - (2) Capricornus
 - (3) Libra
 - (4) Scorpius
-

GO RIGHT ON TO THE NEXT PAGE ⇨

Part B-2

Answer all questions in this part.

Directions (51–65): Record your answers in the spaces provided in your answer booklet. Some questions may require the use of the *2011 Edition Reference Tables for Physical Setting/Earth Science*.

Base your answers to questions 51 and 52 on the diagram below and on your knowledge of Earth science. The diagram represents three containers, *A*, *B*, and *C*, which have the same volume and are filled to the same level with uniform-sized beads. The beads are held in place by a screen across the bottom of each container.

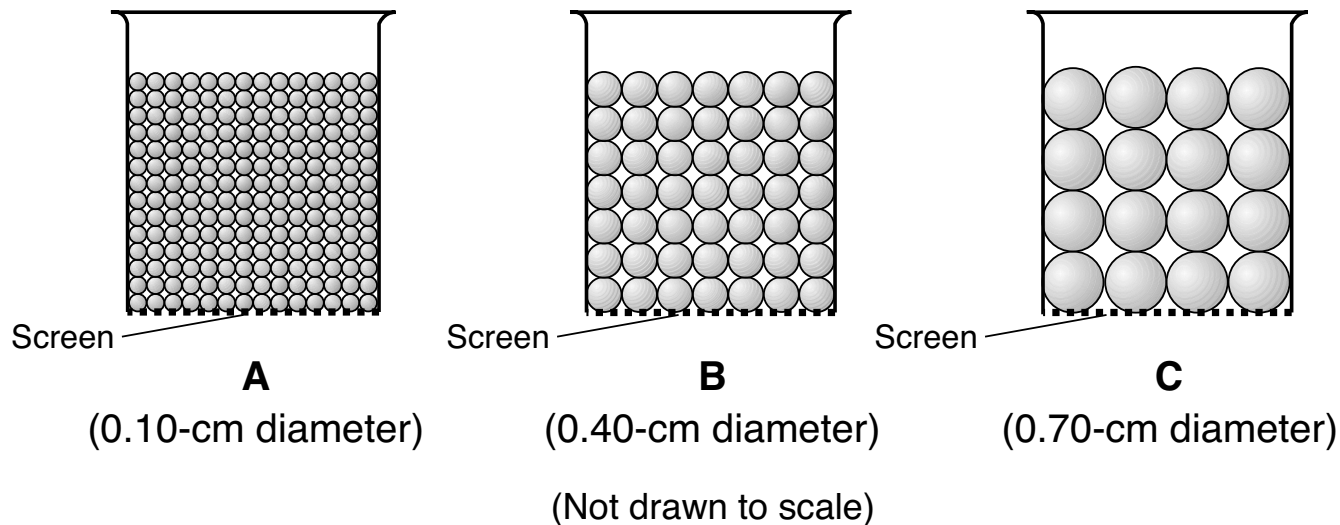

- 51 Draw a line on grid 1 *in your answer booklet* to show the general relationship between bead size and capillarity. Draw a line on grid 2 *in your answer booklet* to show the general relationship between bead size and permeability. [1]
- 52 Describe one way to prepare a fourth container of beads, filled to the same level as shown in *A*, *B*, and *C*, that would reduce porosity. [1]

Base your answers to questions 53 and 54 on the ocean tide diagram below and on your knowledge of Earth science. The diagram represents a north pole (NP) view of Earth and the Moon's orbital position during a spring tide. Spring tides occur when the Sun, Earth, and Moon are aligned, producing high tides that are extremely high and low tides that are extremely low. Point A indicates another position of the Moon in its orbit.

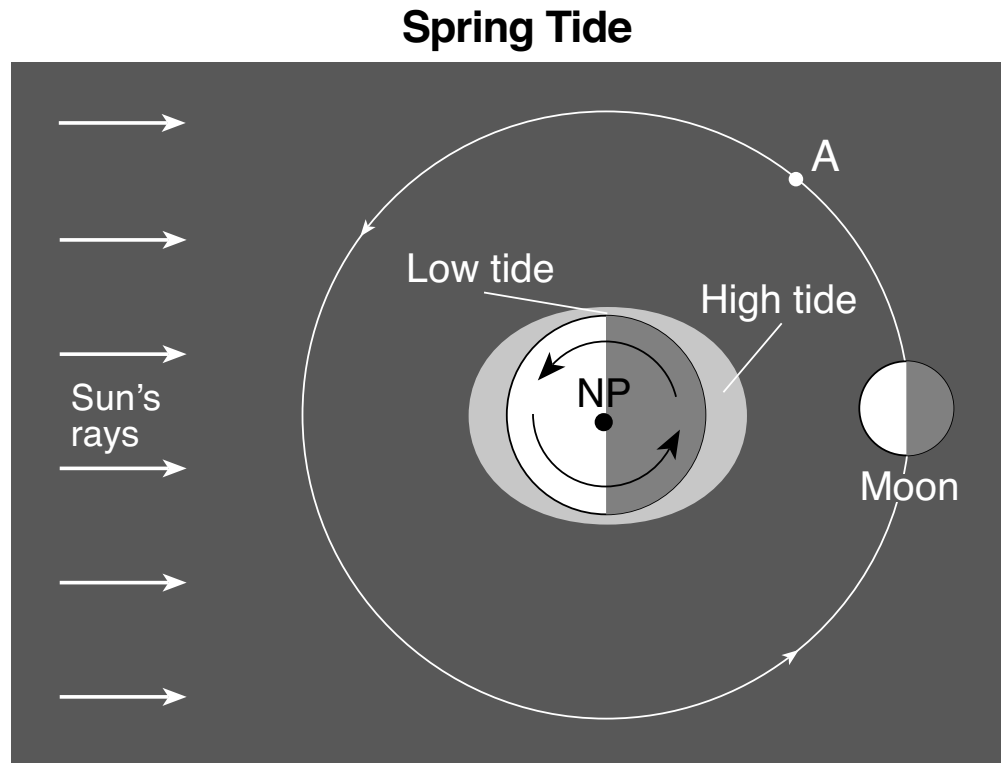

(Not drawn to scale)

- 53 On the diagram *in your answer booklet*, place an **X** on the Moon's orbit to indicate the Moon's position when the next spring tide will occur. [1]
- 54 On the diagram *in your answer booklet*, shade the portion of the Moon that is in darkness, as viewed from New York State, when the Moon is located at position A. [1]

Base your answers to questions 55 through 57 on the map *in your answer booklet* and on your knowledge of Earth science. The map shows a portion of the continent of North America and some of the major rivers. The Rio Grande and the Mississippi River are labeled. Points *A* and *B* represent locations along the Mississippi River. Point *C* represents a location along a river in New York State (NY) that is part of the Mississippi River watershed.

- 55 On the map *in your answer booklet*, place an **X** on the tributary that is located farthest south and flows into the Mississippi River. [1]
- 56 Describe the change in shape and change in size of sediments as they are transported in the Mississippi River from point *A* to point *B*. [1]
- 57 Identify the name of the New York State landscape region where the river at point *C* is located. [1]
-

Base your answers to questions 58 through 61 on the passage below, graph on the next page, and on your knowledge of Earth science. The graph shows changes in the amount of chlorofluorocarbon production, in tons per year (T/y), by some countries over a 10-year period.

CFCs and Ozone

CFCs (chlorofluorocarbons) are chemicals that threaten to destroy stratospheric ozone. CFCs were first manufactured in 1928 to be used as chilling agents in refrigerators. In later years, they were used for cleaning electrical circuit boards and to make foam for insulation. Unfortunately, scientists found that these chemicals escaped into the atmosphere and rose to the stratosphere. In the stratosphere, intense ultraviolet (UV) radiation broke the CFCs down, producing chlorine, a gas that reacts with and destroys ozone. In 1974, two scientists identified the depletion of stratospheric ozone from the release of CFCs. After this discovery, 27 countries agreed to reduce production of CFCs, because ozone in the stratosphere protects all life from the Sun's most damaging UV rays.

GO RIGHT ON TO THE NEXT PAGE ⇨

Production of Chlorofluorocarbons in Selected Countries, 1986-1996

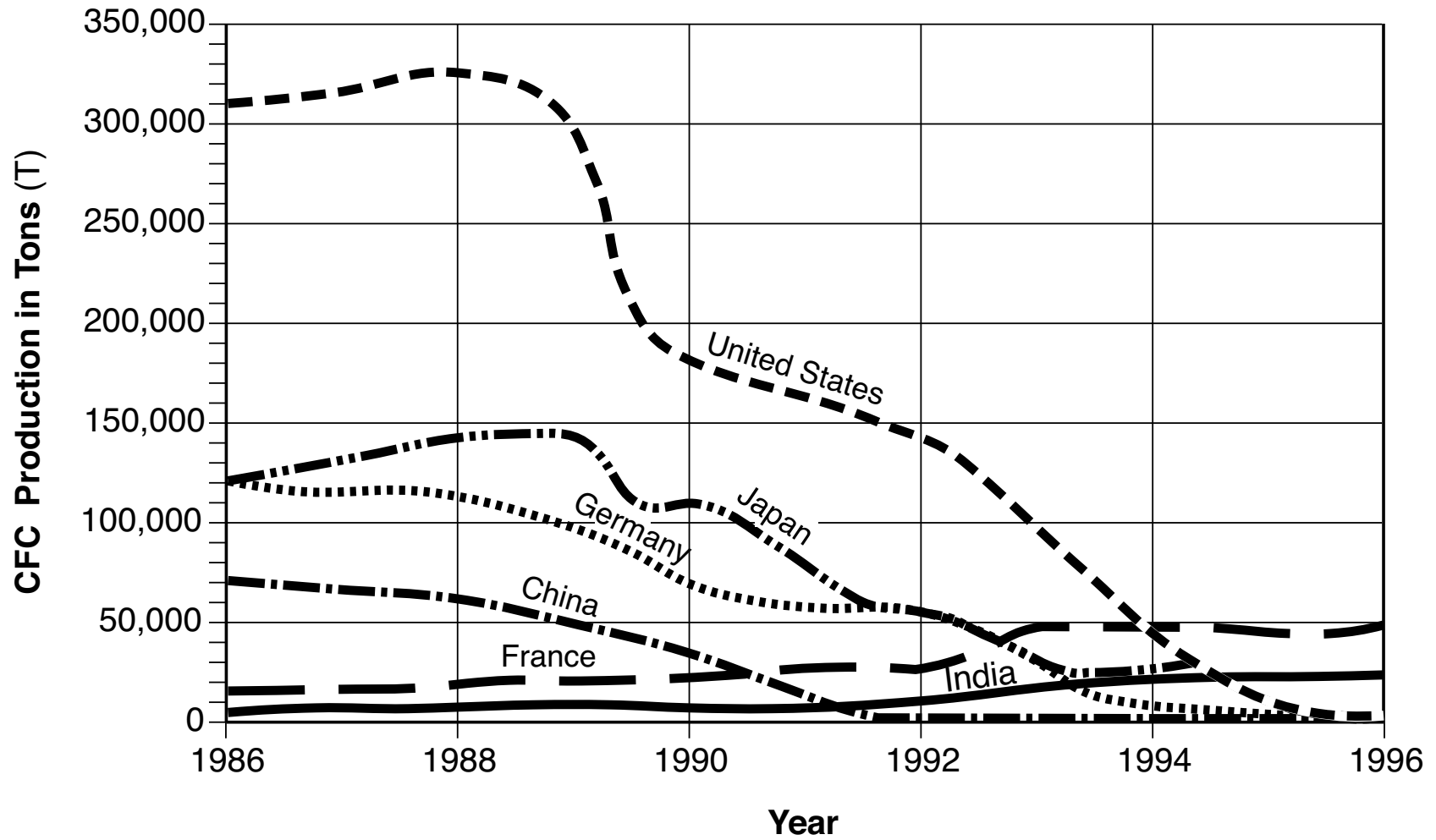

- 58 Write the chemical symbol for the element produced by the breakdown of CFCs. Describe *one* environmental impact that results from this element being released into Earth's stratosphere. [1]
- 59 Identify the name of the atmospheric temperature zones directly below and directly above the atmospheric layer in which intense UV radiation breaks down CFCs. [1]
- 60 Calculate the approximate rate, in tons per year (T/y), at which the United States *decreased* CFC production in the 8 years between 1988 and 1996. [1]
- 61 Based on the graph, identify the *two* countries that began to decrease CFC production as early as 1986. [1]
-

Base your answers to questions 62 through 65 on the diagram below and on your knowledge of Earth science. The diagram represents the formation of coal and other fossil fuels in the environment.

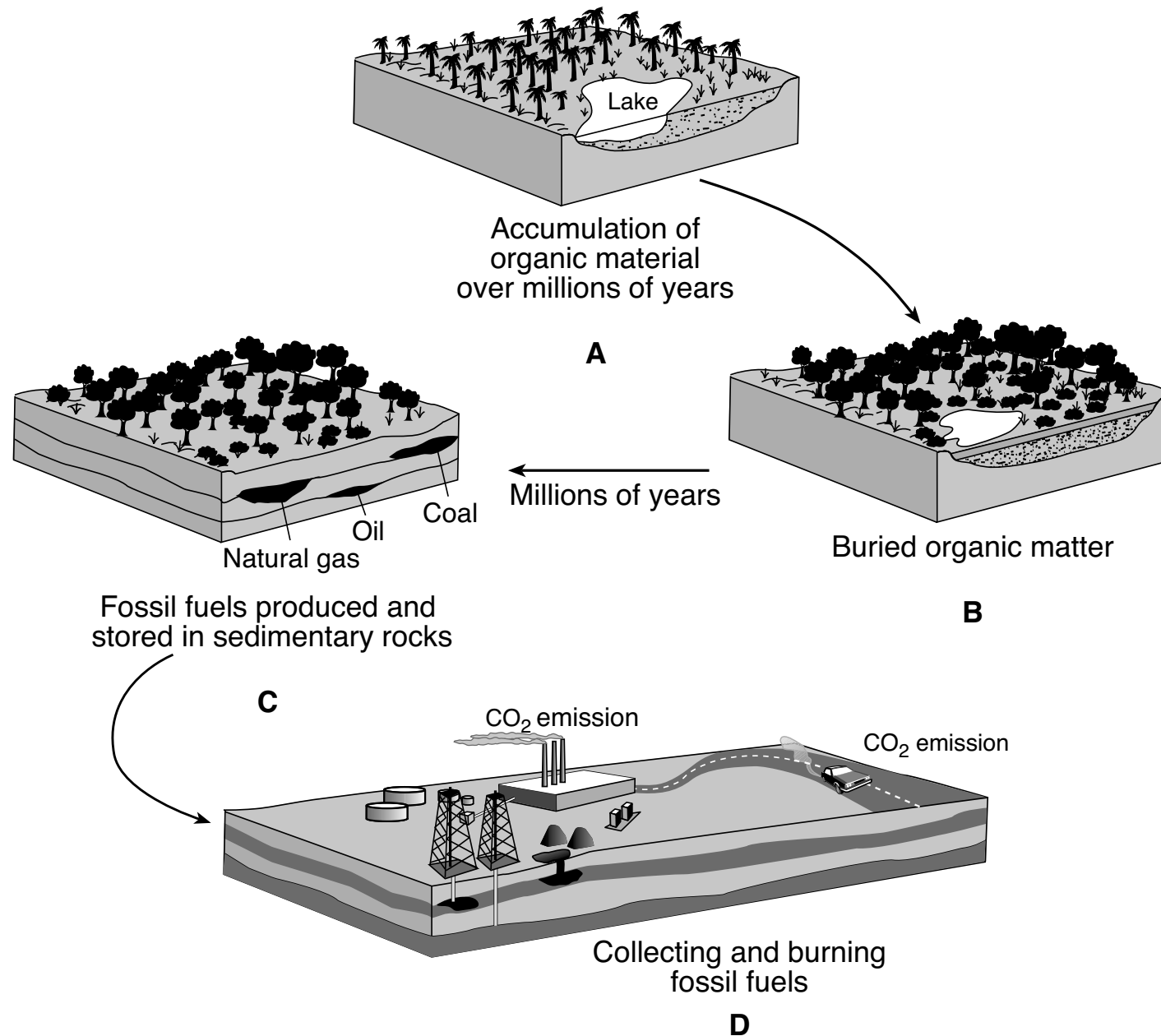

Adapted from: Wright, Richard and Nebel, Bernard. *Environmental Science, Learning System Edition*

- 62 Identify the geologic time period in which the extensive coal-forming forests represented in diagram *A* were most abundant. [1]
- 63 Identify *one* process that changed the buried organic matter of diagram *B* into coal. [1]
- 64 Identify the primary chemical element found in coal. [1]
- 65 The burning of fossil fuels, represented in *D*, produces the greenhouse gas carbon dioxide (CO_2), which is associated with air pollution and global warming. Other than CO_2 , identify *one* other major greenhouse gas. [1]
-

Base your answers to questions 66 through 68 on the topographic map below and on your knowledge of Earth science. Points *A*, *B*, *C*, *D*, and *X* represent surface locations on the map. Lines *AB* and *CD* are reference lines.

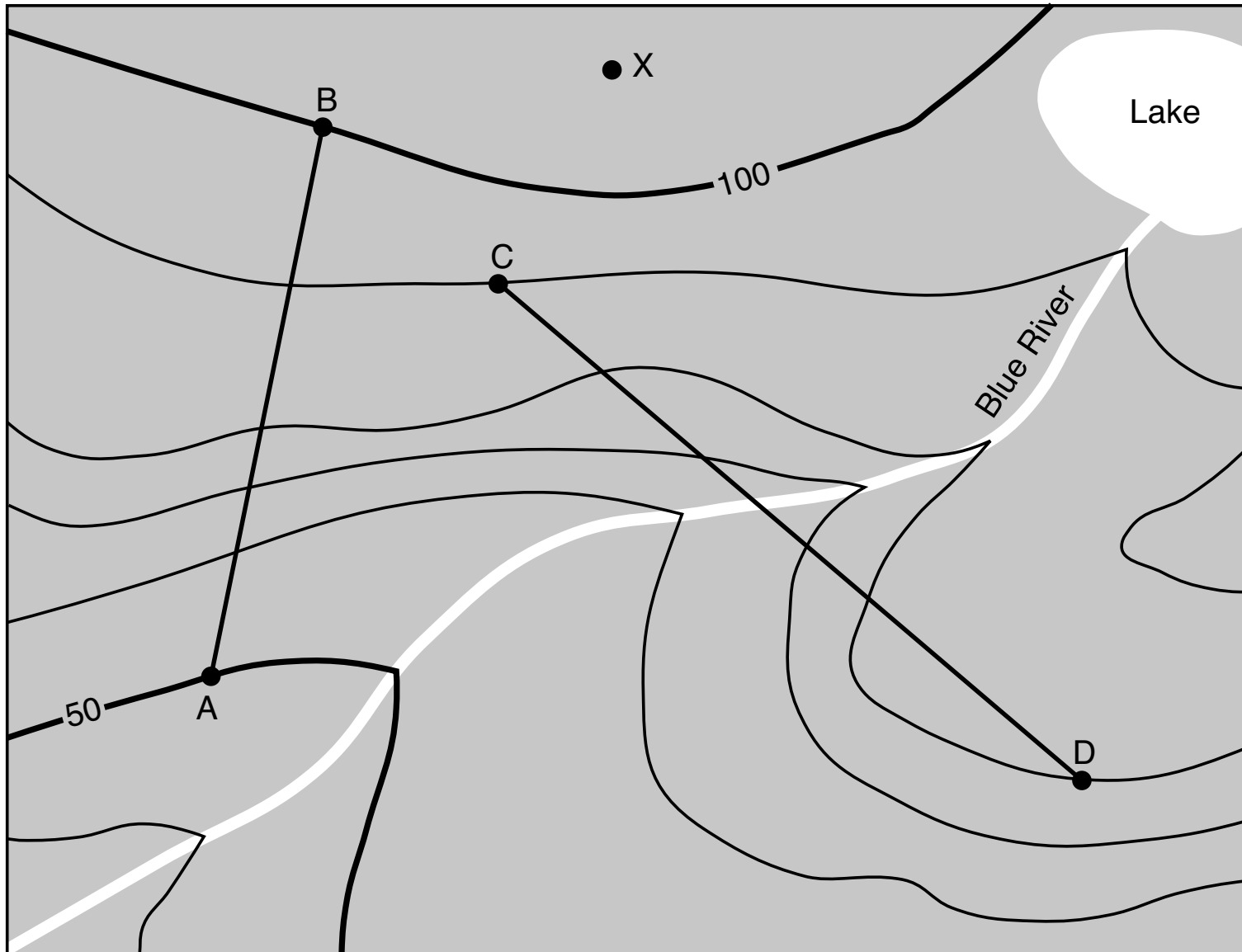

Contour interval = 10 meters

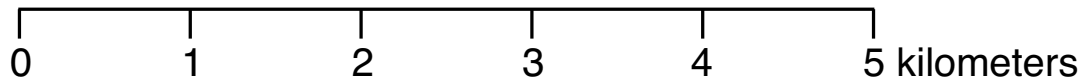

66 Calculate the gradient along the reference line from *A* to *B*. Include units with your answer. [1]

67 On the grid *in your answer booklet*, construct a topographic profile along line *CD* by plotting the elevation of each contour line that crosses line *CD*. Connect *all six* plots with a line to complete the profile. [1]

68 Determine *one* possible elevation of point *X*. [1]

GO RIGHT ON TO THE NEXT PAGE ⇨

Base your answers to questions 69 through 71 on the diagram below and on your knowledge of Earth science. The diagram represents a side view of Earth. The North Pole and some latitudes are labeled. The dashed line represents Earth's axis.

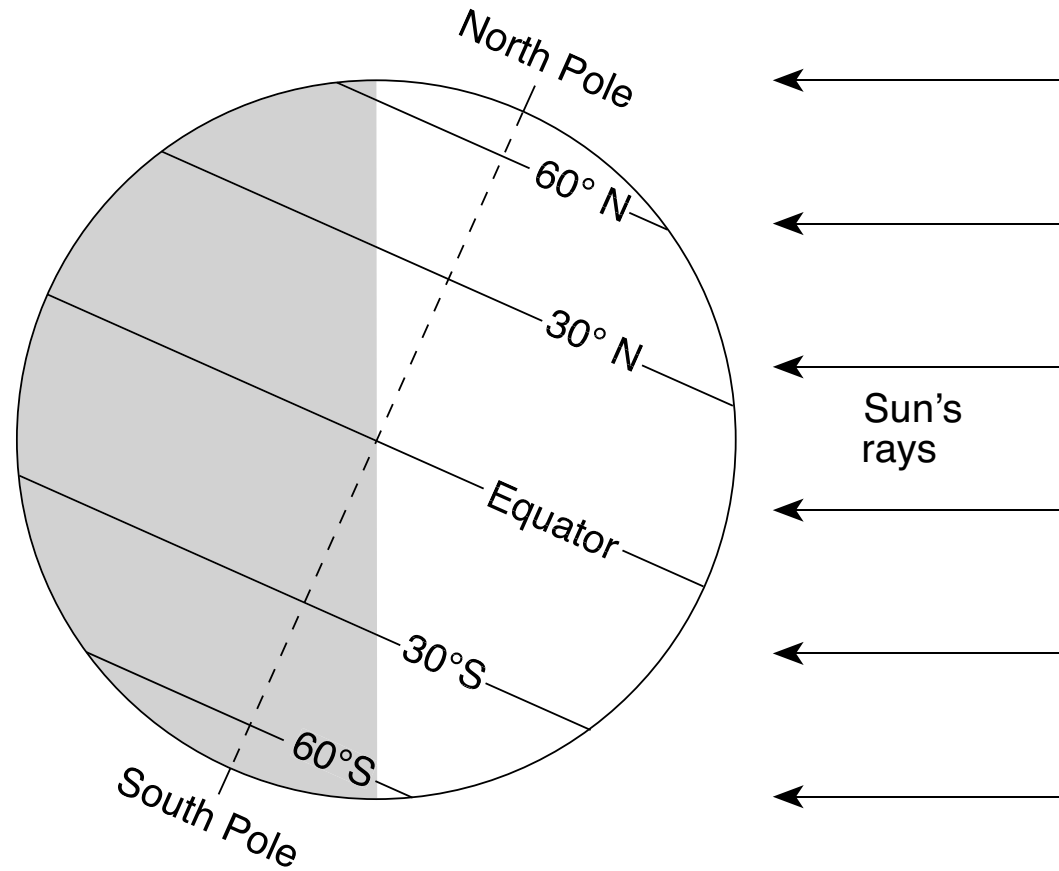

- 69 Identify the season that is just beginning in the Northern Hemisphere when Earth is in this position. [1]
- 70 State the number of hours of daylight that would be experienced at the Equator three months after the date represented by this diagram. [1]
- 71 State the general relationship between latitude and the duration of insolation on this day from the Equator to 60° N. [1]
-

GO RIGHT ON TO THE NEXT PAGE ⇨

Base your answers to questions 72 through 75 on the passage and map below and on your knowledge of Earth science. The map shows the location of a major earthquake that occurred in 2010 off the west coast of Chile, in South America. The star  represents the location of the earthquake epicenter.

On February 27, 2010, a strong earthquake with a magnitude of 8.8 occurred off the west coast of South America near the city of Concepción in central Chile. There was tremendous damage to the region and loss of life, as buildings collapsed. Tremors were felt as far north as Ica, Peru, 2400 kilometers away. The earthquake triggered a tsunami that damaged several coastal towns. Tsunami warnings were issued to 53 countries, including the United States, where damage was reported. This earthquake is ranked as one of the highest in magnitude ever recorded by a seismograph. Chile has experienced some of the strongest earthquakes in the past, including a 1960 earthquake that had a magnitude of 9.5, the highest ever recorded.

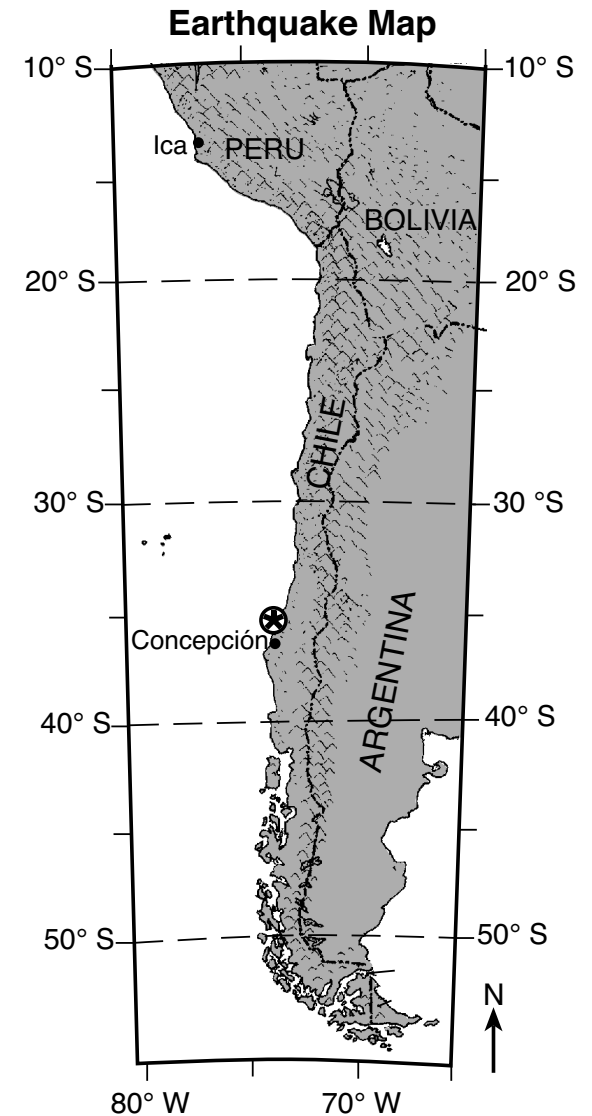

- 72 On the block diagram of the tectonic plate boundary *in your answer booklet*, draw *two* arrows, one in each box, to indicate the general direction that each plate moved in relation to each other, causing the 2010 Chile earthquake to occur. [1]
- 73 Identify the name of the oceanic tectonic plate located along the west coast of South America where this earthquake occurred. [1]
- 74 Determine the *P*-wave travel time, in minutes and seconds, from this earthquake's epicenter to the tremors that were felt in Ica, Peru. [1]
- 75 Describe *one* action that coastal residents should have taken in response to the tsunami warnings that would have reduced loss of life. [1]
-

Base your answers to questions 76 through 78 on the data table below, on the map in your answer booklet, and on your knowledge of Earth science. The table lists storm data for Hurricane Matthew, which occurred in the fall of 2016. Air pressure, wind speed, and storm location are shown for the hurricane's center at the same time each day. The map shows the location of Hurricane Matthew from September 28 to October 4.

Hurricane Matthew Data

Date	Air Pressure (mb)	Wind Speed (mph)	Location of Storm Center
Sept. 28	1008	60	13° N, 61° W
Sept. 29	995	70	14° N, 66° W
Sept. 30	968	115	14° N, 71° W
Oct. 1	946	145	13° N, 74° W
Oct. 2	946	140	14° N, 75° W
Oct. 3	941	140	16° N, 75° W
Oct. 4	949	145	19° N, 74° W
Oct. 5	962	120	22° N, 75° W
Oct. 6	940	140	25° N, 78° W
Oct. 7	946	120	29° N, 81° W
Oct. 8	967	75	33° N, 79° W
Oct. 9	984	75	35° N, 74° W

76 On the map *in your answer booklet*, complete the path of Hurricane Matthew by plotting the location of the storm center for October 5 through October 9. Draw a line to connect *all five* of these plots to the October 4 plot to complete the path. [1]

77 Identify the *two* consecutive dates between which the greatest *decrease* in air pressure occurred. [1]

78 The table below shows the Saffir-Simpson Scale, which is used to classify hurricanes.

Saffir-Simpson Scale

Classification of Hurricane	Wind Speed (mph)
Category 1	74-95
Category 2	96-110
Category 3	111-129
Category 4	130-156
Category 5	≥157

Identify the greatest wind speed of Hurricane Matthew listed on the data table, and identify the classification of Hurricane Matthew based on this wind speed. [1]

Base your answers to questions 79 through 81 on the diagrams below and on your knowledge of Earth science. The diagrams represent three sedimentary rock outcrops labeled I, II, and III, found in the northeastern United States. The outcrops have *not* been overturned. Some rock layers contain New York State index fossils. One unconformity has been labeled X.

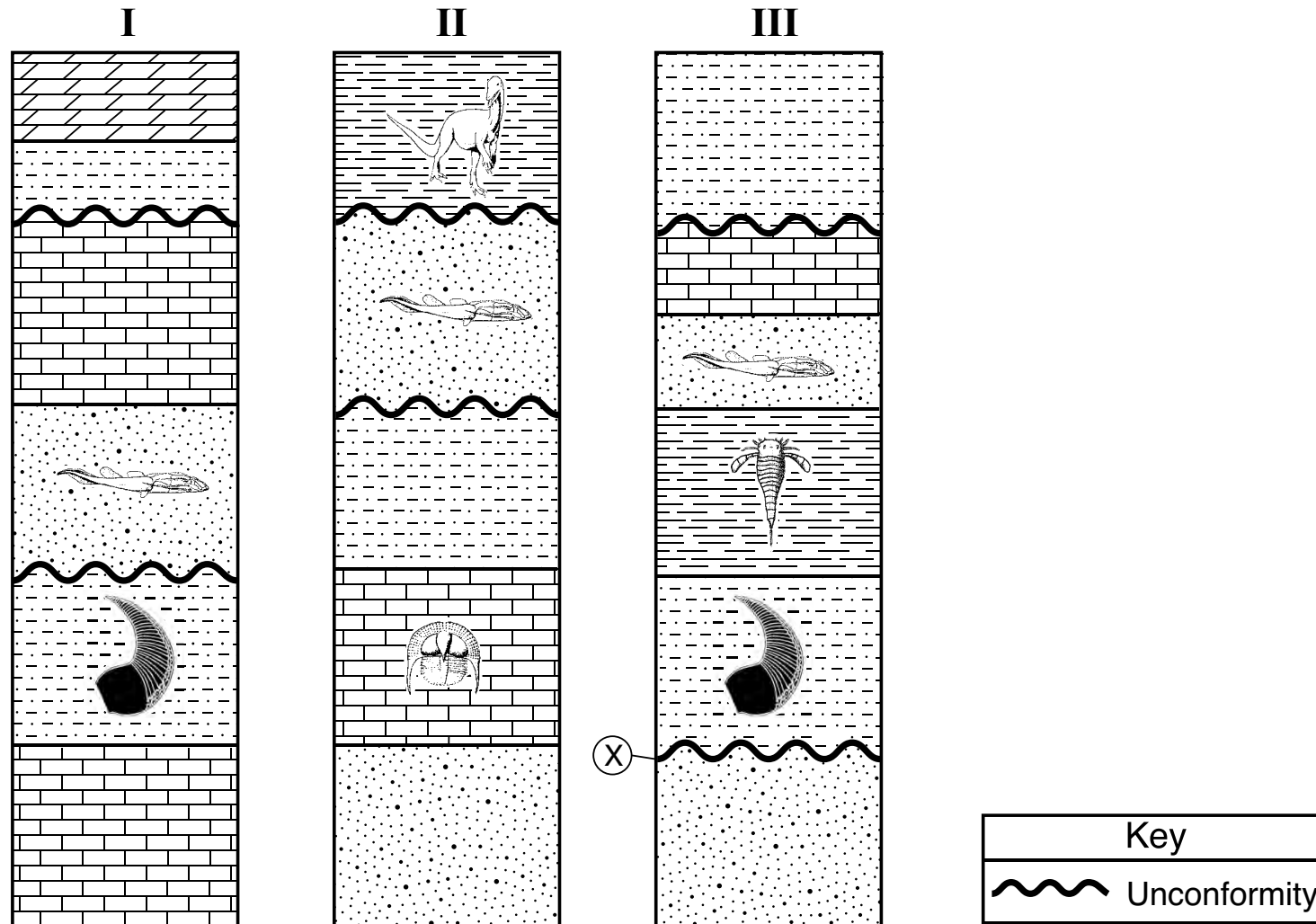

- 79 Identify the names of the *two* index fossils found in these rock layers that represent organisms that could have been alive at the same time. [1]
- 80 Good index fossils are often abundant or easily identified. Describe *one* other characteristic of these fossils that makes them index fossils. [1]
- 81 Identify, by name, the sedimentary rock layer that is missing from rock outcrop III due to the formation of unconformity X. [1]
-

GO RIGHT ON TO THE NEXT PAGE ⇨

Base your answers to questions 82 through 85 on the information and data table below and on your knowledge of Earth science. The table shows data for the six planets in the *Kepler-11* star system.

Kepler-11 is one of many star systems discovered by space satellites. Scientists find this system unusual because of its small size and its six planets, identified by letters *b* through *g*, that orbit relatively close to its central star. The central star, *Kepler-11*, has a surface temperature of 5663 K and a luminosity of 1.0.

Planet	Mean Distance from Star (million km)	Period of Revolution (days)	Eccentricity of Orbit	Equatorial Diameter (km)	Density (g/cm³)
Kepler-11b	13.7	10.3	0.045	45,869	1.70
Kepler-11c	16.0	13.0	0.026	73,151	0.66
Kepler-11d	23.2	22.7	0.004	79,528	1.28
Kepler-11e	29.1	32.0	0.012	106,780	0.58
Kepler-11f	37.5	46.7	0.013	63,456	0.69
Kepler-11g	69.7	118.4	0.150	84,847	1.20

- 82 Describe the relationship between a planet's mean distance from this star and the period of revolution. [1]
- 83 The diagram *in your answer booklet* represents the scaled distances of Mercury, Venus, and Earth from the Sun. Place an **X** on the line to indicate where *Kepler-11c* would be located if it were in our solar system. [1]
- 84 Identify the *two* planets in our solar system that have an orbital shape most similar to the orbital shape of *Kepler-11b*. [1]
- 85 Identify the star located on the *Characteristics of Stars* graph on the *Physical Setting/Earth Science Reference Tables* that has the most similar surface temperature and luminosity as the *Kepler-11 star*. [1]
-

