

Large-Type Edition

The University of the State of New York

REGENTS HIGH SCHOOL EXAMINATION

PHYSICAL SETTING EARTH SCIENCE

Thursday, August 17, 2023 — 8:30 to 11:30 a.m., only

The possession or use of any communications device is strictly prohibited when taking this examination. If you have or use any communications device, no matter how briefly, your examination will be invalidated and no score will be calculated for you.

Use your knowledge of Earth science to answer all questions in this examination. Before you begin this examination, you must be provided with the *2011 Edition Reference Tables for Physical Setting/Earth Science*. You will need these reference tables to answer some of the questions.

You are to answer all questions in all parts of this examination. You may use scrap paper to work out the answers to the questions, but be sure to record your answers on your answer sheet and in your answer booklet. A separate answer sheet for Part A and Part B–1 has been provided to you. Follow the instructions from the proctor for completing the student information on your answer sheet. Record your answers to the Part A and Part B–1 multiple-choice questions on this separate answer sheet. Record your answers for the questions in Part B–2 and Part C in your separate answer booklet. Be sure to fill in the heading on the front of your answer booklet.

All answers in your answer booklet should be written in pen, except for graphs and drawings, which should be done in pencil.

When you have completed the examination, you must sign the declaration printed on your separate answer sheet, indicating that you had no unlawful knowledge of the questions or answers prior to the examination and that you have neither given nor received assistance in answering any of the questions during the examination. Your answer sheet and answer booklet cannot be accepted if you fail to sign this declaration.

Notice ...

A four-function or scientific calculator and a copy of the *2011 Edition Reference Tables for Physical Setting/Earth Science* must be available for you to use while taking this examination.

DO NOT START THIS EXAMINATION UNTIL THE SIGNAL IS GIVEN.

Part A

Answer all questions in this part.

Directions (1–35): For *each* statement or question, choose the word or expression that, of those given, best completes the statement or answers the question. Some questions may require the use of the *2011 Edition Reference Tables for Physical Setting/Earth Science*. Record your answers on your separate answer sheet.

- 1 Which two factors caused Earth and the other planets to become layered during the formation of our solar system?
- (1) gravity and densities of materials making up the planet
 - (2) gravity and percent of water in the planet's composition
 - (3) distance from the Moon and densities of materials making up the planet
 - (4) distance from the Moon and percent of water in the planet's composition

- 2 The photograph below shows an object, labeled A, that was observed in the night sky for several weeks.



What is the celestial object labeled A?

- (1) a meteor
- (2) an asteroid
- (3) a galaxy
- (4) a comet

3 The latitudes of the Tropic of Cancer and the Tropic of Capricorn are determined by Earth's

- (1) rotation
- (2) axial tilt
- (3) surface ocean currents
- (4) average surface air temperature

4 The Coriolis effect can best be used to explain the

- (1) cyclic time pattern of ocean tides
- (2) direction of convection currents in the asthenosphere
- (3) deflection of winds to the right in the Northern Hemisphere
- (4) movement of air in a straight path from low pressure to high pressure

5 What is Earth's approximate rate of revolution?

- (1) $1^\circ/\text{hour}$
- (2) $1^\circ/\text{day}$
- (3) $15^\circ/\text{hour}$
- (4) $15^\circ/\text{day}$

6 At a location in the Northern Hemisphere, a camera was placed outside at night with the lens pointing at a group of stars. The shutter was left open for a few hours, resulting in the image of star trails shown below.

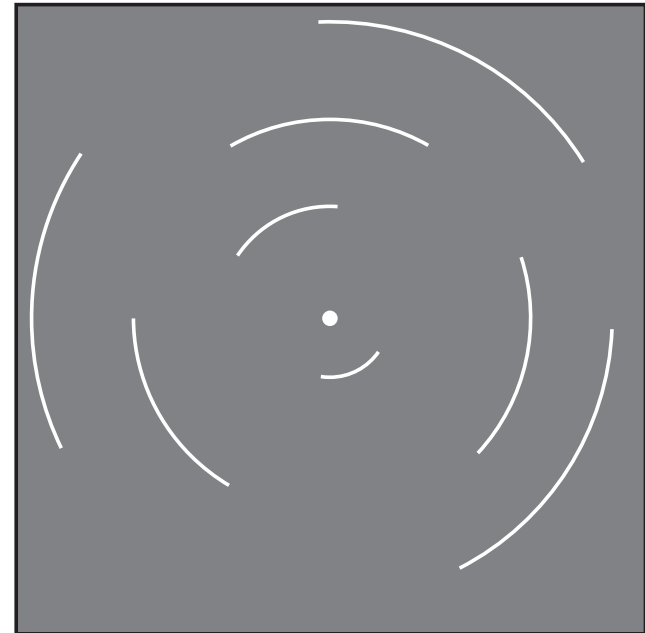

The star at the center of the image did not leave a trail because the star is

- (1) too far away to observe its movement
- (2) too massive to move in space
- (3) not luminous enough to leave a trail
- (4) centered over Earth's axis

7 Which table best lists the differences between a terrestrial planet and a Jovian planet in our solar system?

(1)

Terrestrial Planet	Jovian Planet
mainly rocky in composition	mainly gaseous in composition
small in size	large in size

(2)

Terrestrial Planet	Jovian Planet
mainly gaseous in composition	mainly rocky in composition
small in size	large in size

(3)

Terrestrial Planet	Jovian Planet
mainly rocky in composition	mainly gaseous in composition
large in size	small in size

(4)

Terrestrial Planet	Jovian Planet
mainly gaseous in composition	mainly rocky in composition
large in size	small in size

8 The names and appearances of four Moon phases viewed by an observer in New York State in June are shown below.

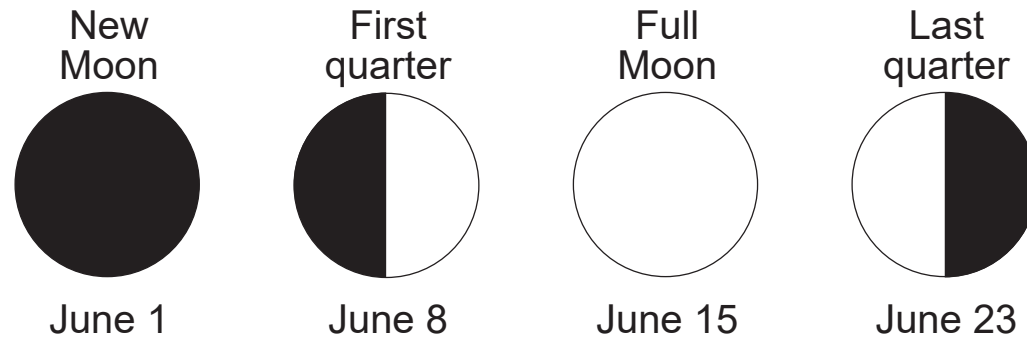

Which diagram best represents the Moon's appearance on June 3?

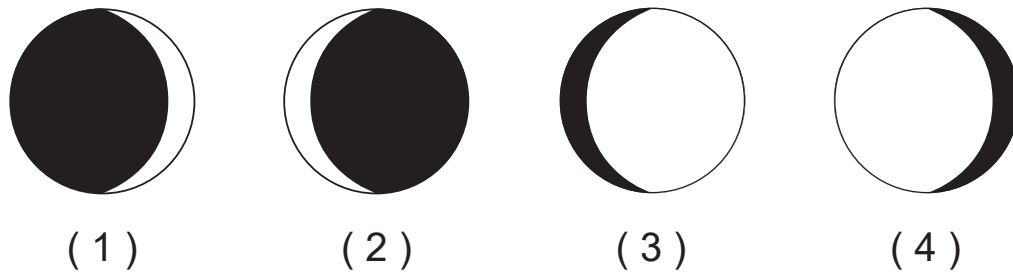

9 Which graph most accurately represents the approximate percentage of Earth's surface covered by the hydrosphere?

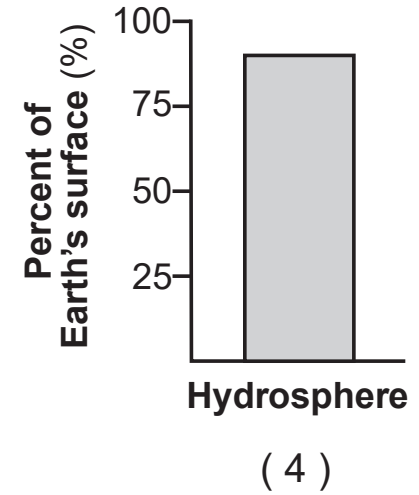
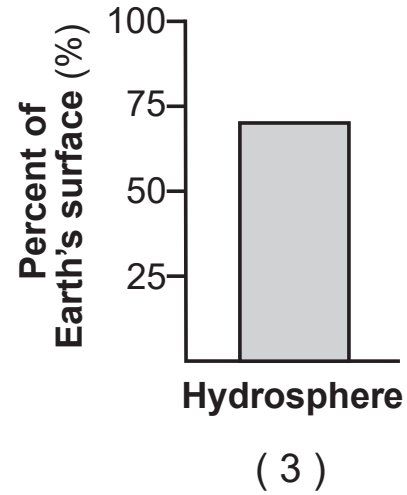
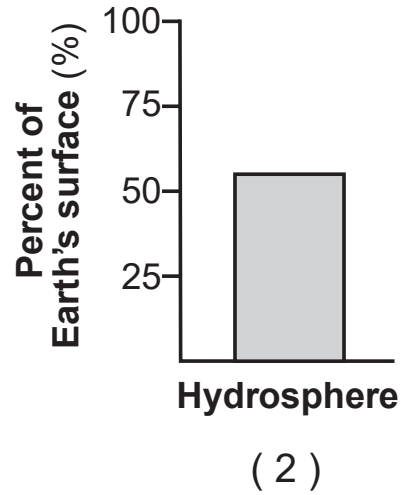
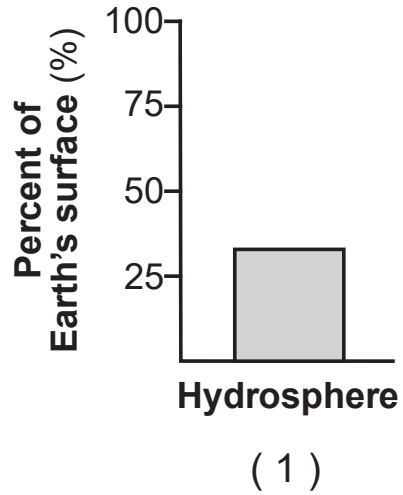

10 Which diagram shows the correct position of Polaris in the night sky as seen by an observer at Watertown, NY?

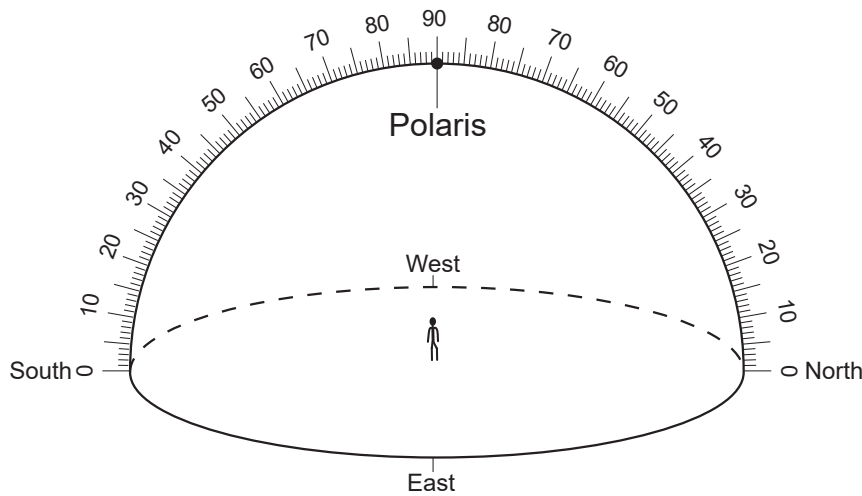

(1)

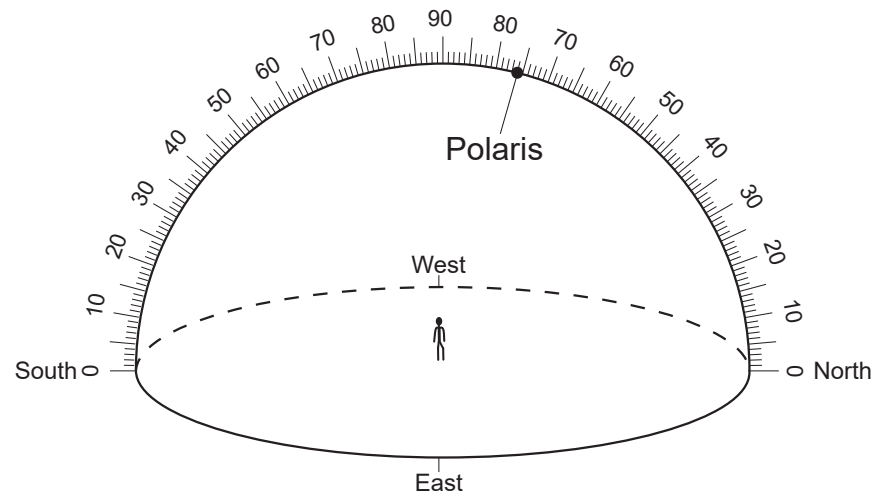

(3)

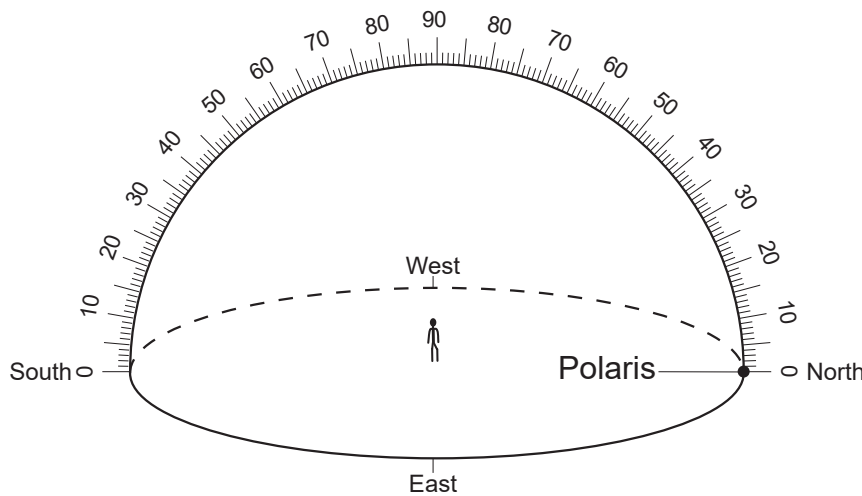

(2)

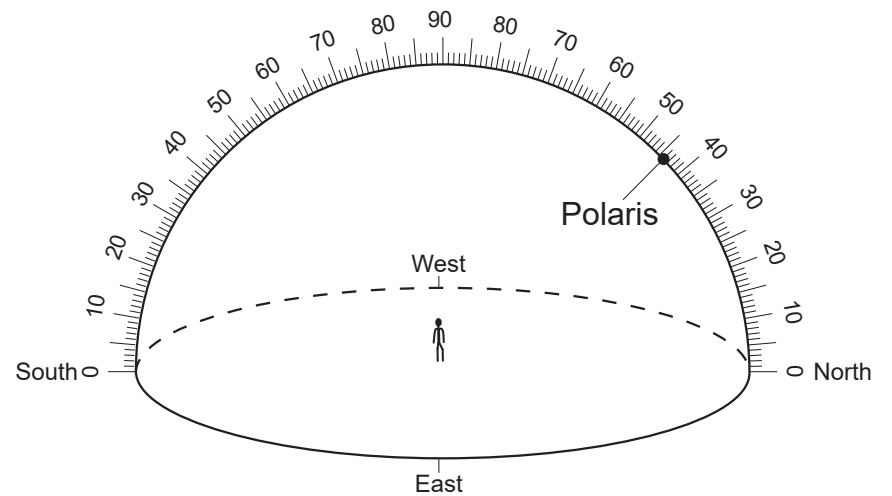

(4)

11 Which process transports groundwater upward through the soil to the surface, where it quickly evaporates during a dry season?

- (1) capillarity
- (2) convection
- (3) infiltration
- (4) saturation

12 The diagram below represents four cylinders of particles, labeled 1 through 4. Cylinders 1 through 3 each contain equal volumes of round particles of uniform size. Cylinder 4 contains round mixed-size particles. Sizes of particles are indicated for each cylinder.

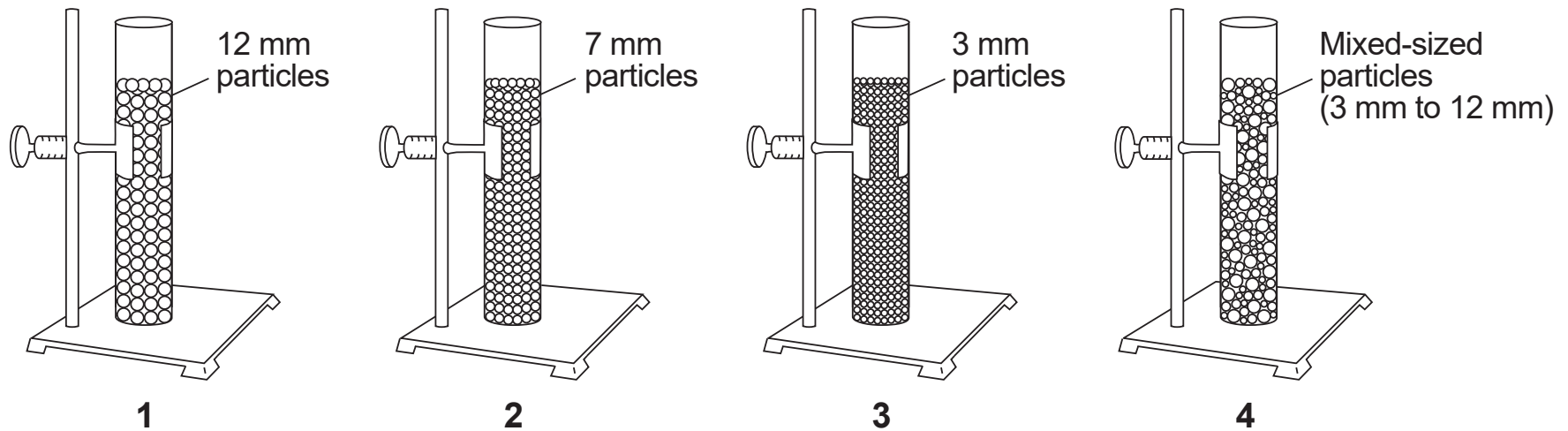

(Not drawn to scale)

Which cylinder contains the particles with the *lowest* porosity?

- (1) 1
- (2) 2
- (3) 3
- (4) 4

13 Which factor is responsible for the circulation of convection currents occurring in the hydrosphere, troposphere, and mantle?

- (1) radioactive decay
- (2) solar radiation

- (3) density differences
- (4) planetary winds

14 The arrows on the two maps below show how the monsoon winds blow over India during the summer and winter seasons.

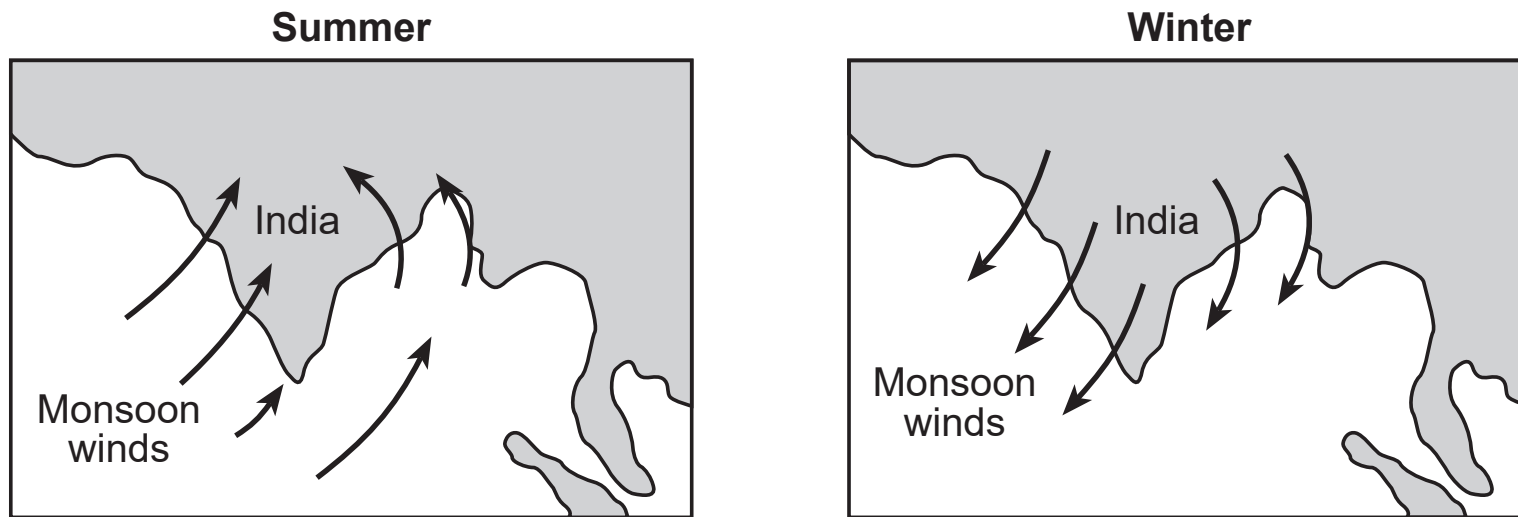

Compared to the amount of rainfall that India receives during the summer monsoon season, the amount of rainfall that India receives during the winter monsoon season is

- (1) less because winds blow from the water to the land
- (2) less because winds blow from the land to the water
- (3) more because winds blow from the water to the land
- (4) more because winds blow from the land to the water

Base your answers to questions 15 and 16 on the map below and on your knowledge of Earth science. The map shows the location of the polar front jet stream during winter. This winter weather pattern brings extremely cold air from the far north into the United States.



15 Which map shows the type of air mass and the direction of polar front jet stream flow associated with this winter weather pattern?



(1)

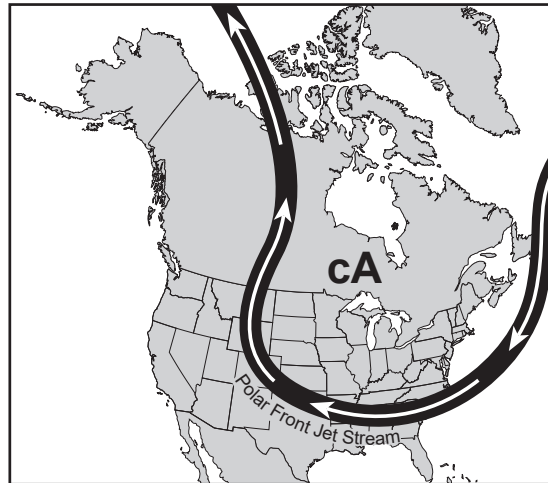

(3)

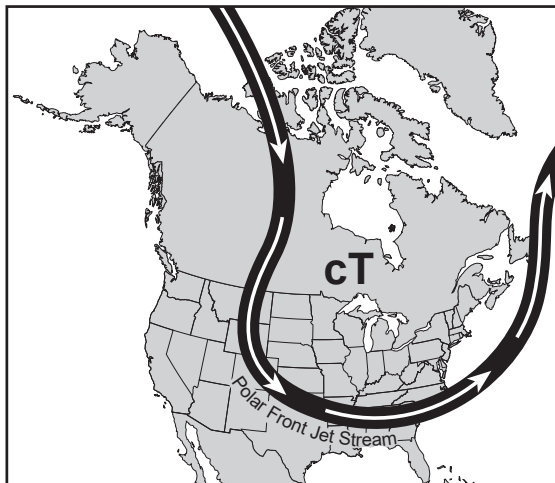

(2)

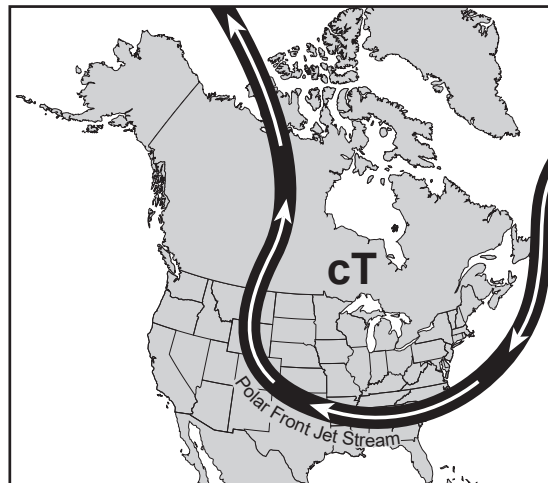

(4)

16 In which atmospheric temperature zone is the polar front jet stream located?

(1) thermosphere

(3) stratosphere

(2) mesosphere

(4) troposphere

17 Which diagram correctly matches the weather front symbol with its atmospheric cross section?

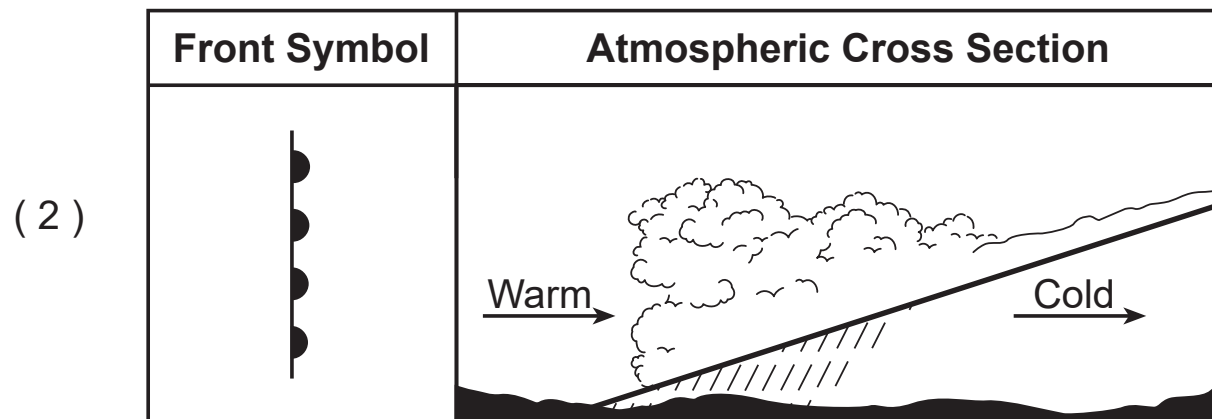
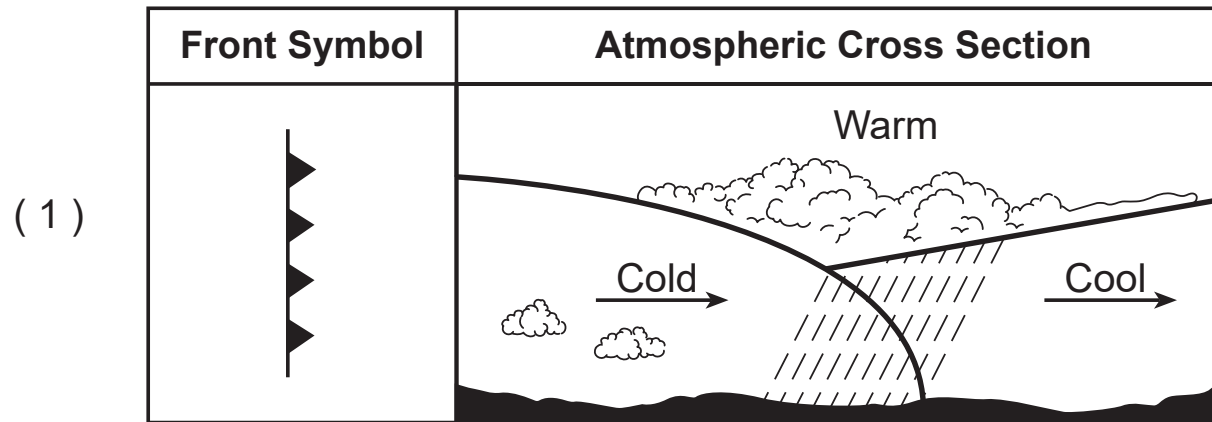

Questions 17 is continued on the next page.

Questions 17 is continued

(3)

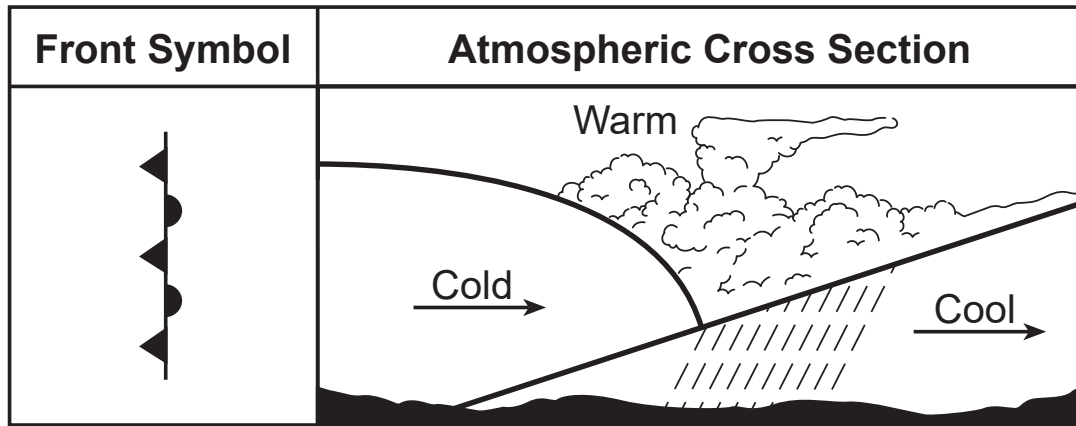

(4)

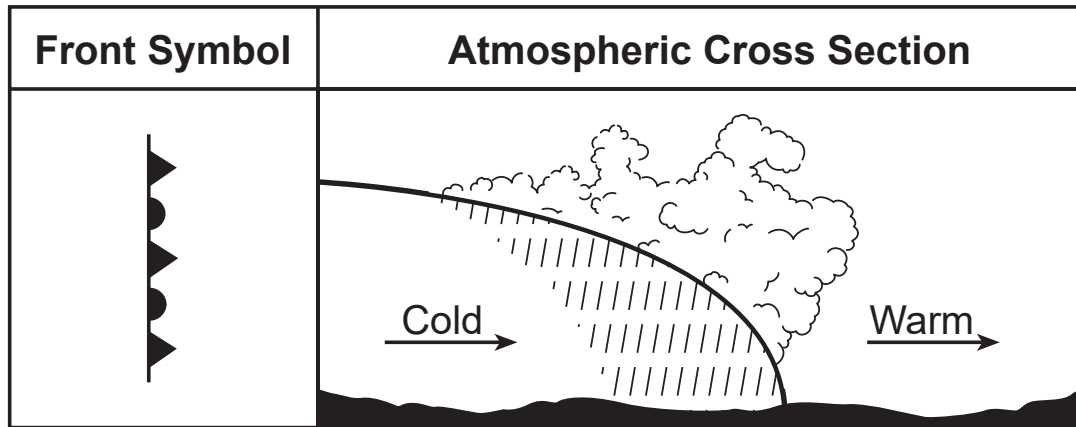

18 If the Tug Hill Plateau region of New York State is experiencing lake-effect snow, winds are most likely blowing in which direction?

- (1) north to south
- (2) south to north
- (3) east to west
- (4) west to east

19 Which set of psychrometer measurements was recorded when the dewpoint was 4°C?

- (1) dry bulb, 4°C; wet bulb, 1°C
- (2) dry bulb, 14°C; wet bulb, 9°C
- (3) dry bulb, 20°C; wet bulb, 16°C
- (4) dry bulb, 28°C; wet bulb, 13°C

20 Compared to the summer and winter temperatures at low elevations, higher elevations at the same latitude have

- (1) warmer summers and warmer winters
- (2) warmer summers and cooler winters
- (3) cooler summers and cooler winters
- (4) cooler summers and warmer winters

21 During which geologic period did humans first appear on Earth?

- (1) Quaternary
- (2) Paleogene
- (3) Triassic
- (4) Permian

22 The graph below shows the radioactive decay of potassium-40.

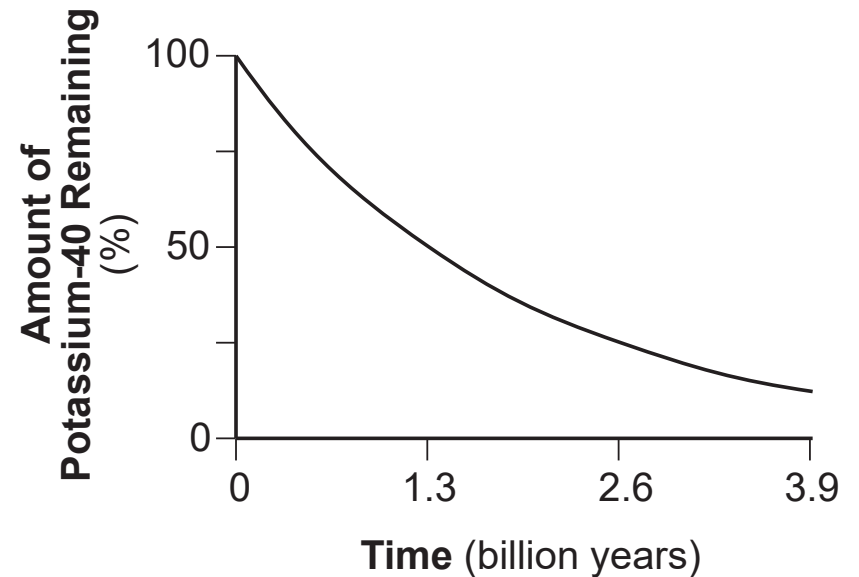

Approximately what percentage of potassium-40 remains in the 1.0 billion-year-old bedrock of the Hudson Highlands landscape region of New York State?

- (1) 10%
- (2) 25%
- (3) 60%
- (4) 75%

- 23 The surface bedrock at Old Forge, New York, is mostly
- (1) flat-lying, sedimentary rock formed during the Grenville Orogeny
 - (2) flat-lying, sedimentary rock formed during the Acadian Orogeny
 - (3) intensely metamorphosed rock formed during the Grenville Orogeny
 - (4) intensely metamorphosed rock formed during the Acadian Orogeny

- 24 Which agent of erosion produced many of the large parallel grooves and scratches seen in surface bedrock across New York State?
- (1) mass movement
 - (2) wind
 - (3) running water
 - (4) glaciers

- 25 The diagram below represents rock A changing into rock B.

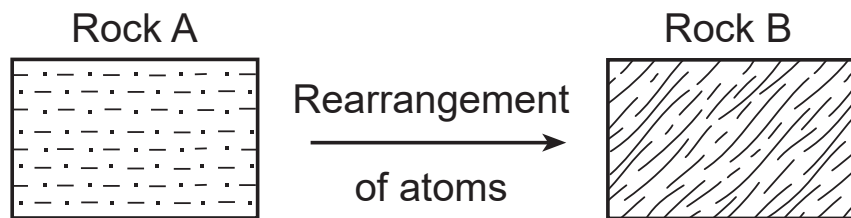

Which process causes rock A to change into rock B?

- (1) melting
- (2) solidification
- (3) precipitation
- (4) metamorphism

- 26 Which mineral is usually present in pegmatite, phyllite, and siltstone?
- (1) quartz
 - (2) garnet
 - (3) olivine
 - (4) pyroxene

- 27 The table below shows the hardness of some common items.

Item	Hardness
fingernail	2.5
penny coin	3
iron nail	4.5
steel file	6

Which mineral could be scratched by an iron nail, but not by a penny coin?

- (1) quartz
- (2) halite
- (3) dolomite
- (4) amphibole

28 Which graph shows the general relationship between an increase in urbanization in an area and the average annual air temperature for that area?

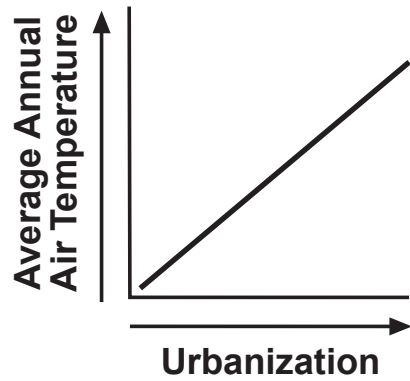

(1)

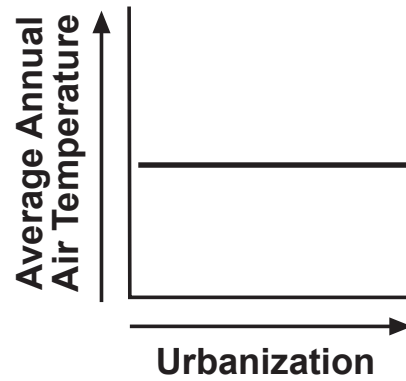

(2)

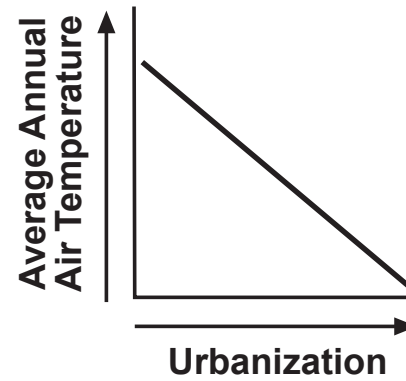

(3)

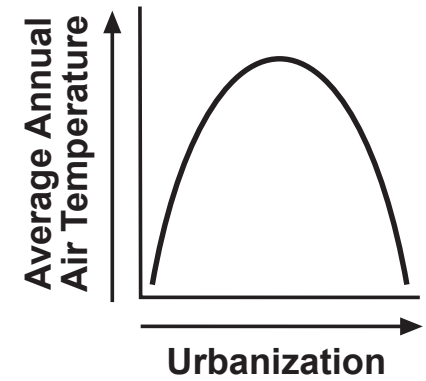

(4)

29 The cross section below represents sedimentary rock layers *A*, *B*, and *C*. An igneous intrusion is labeled *D*. Line *E* represents a fault. Overturning has *not* occurred.

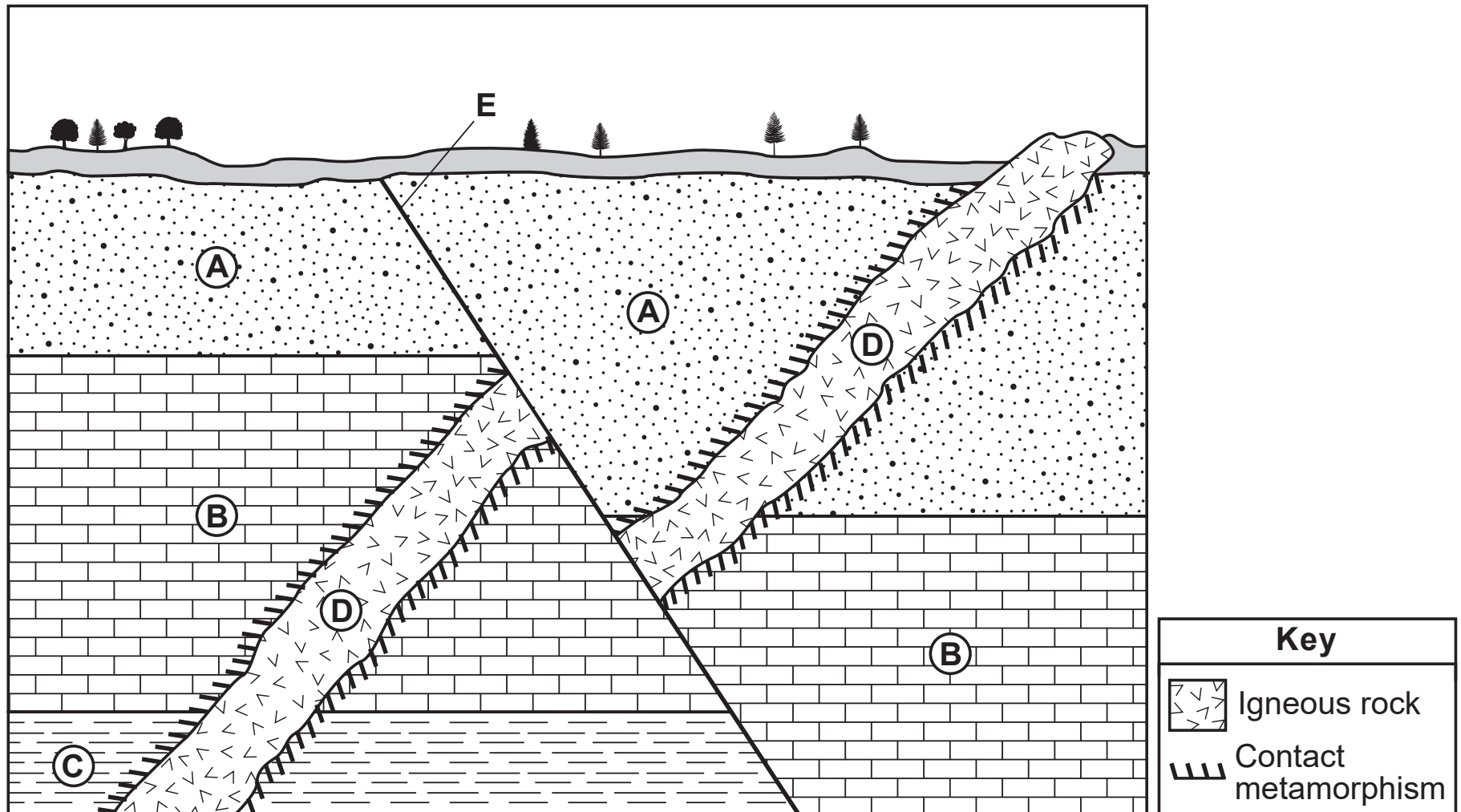

Which events occurred after the formation of rock layer *A*?

- (1) igneous intrusion *D* and faulting at *E*
- (2) deposition of sediments in rock layers *B* and *C*
- (3) faulting at *E* and deposition of sediments in rock layer *C*
- (4) formation of sedimentary rock layer *B* and igneous intrusion *D*

31 Letters *A* through *D* on the block diagram below represent four features resulting from glaciers.

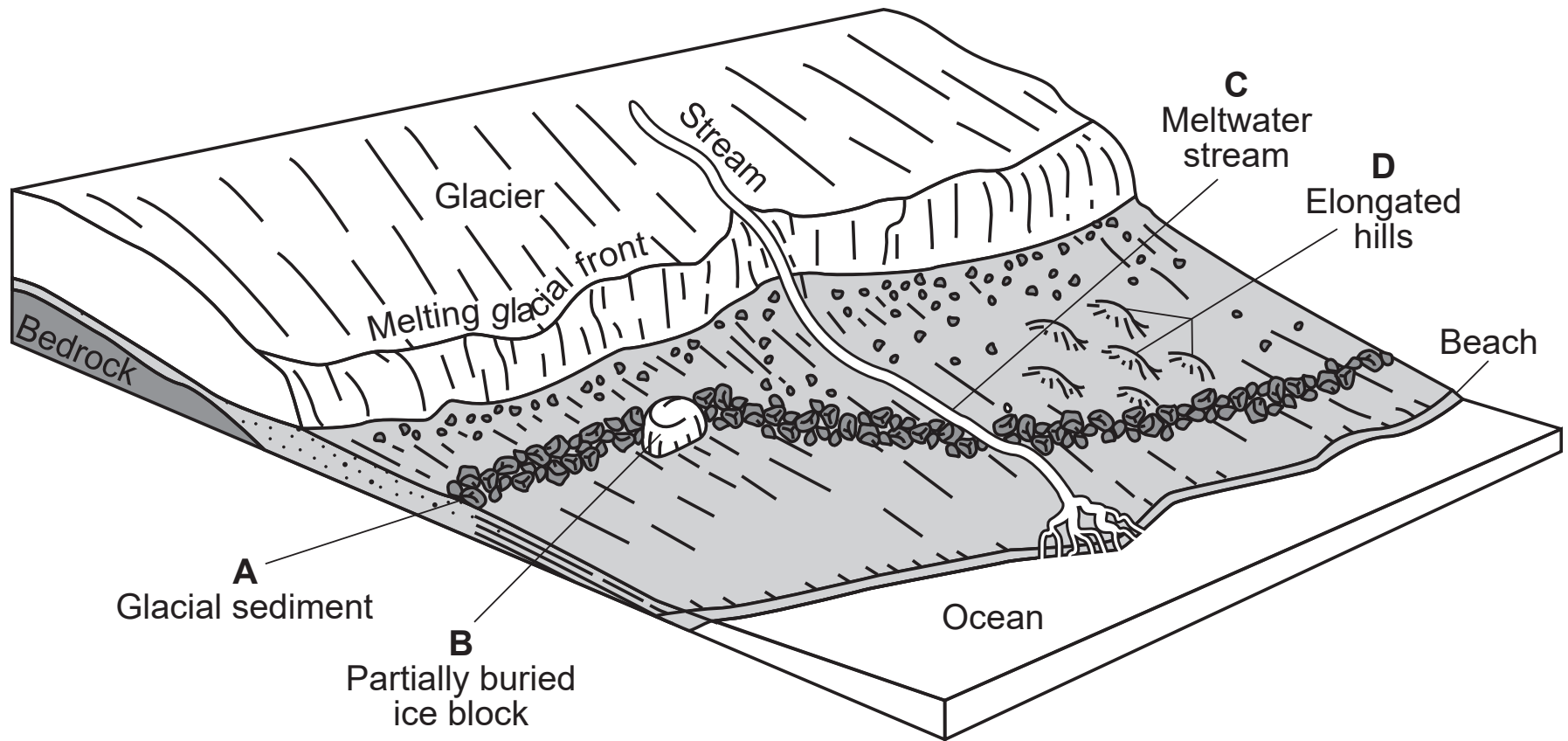

(Not drawn to scale)

Which feature will later form a kettle lake?

- (1) *A*
- (2) *B*
- (3) *C*
- (4) *D*

32 A seismic station is located 2000 kilometers from the epicenter of an earthquake. Which seismogram indicates the correct time difference between the arrival of the first *P*-wave and the first *S*-wave at this station?

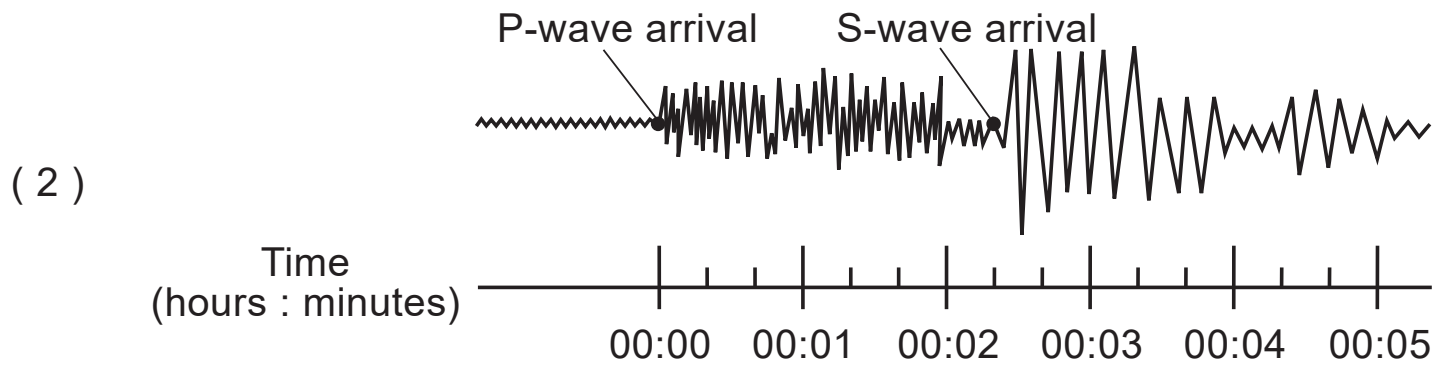
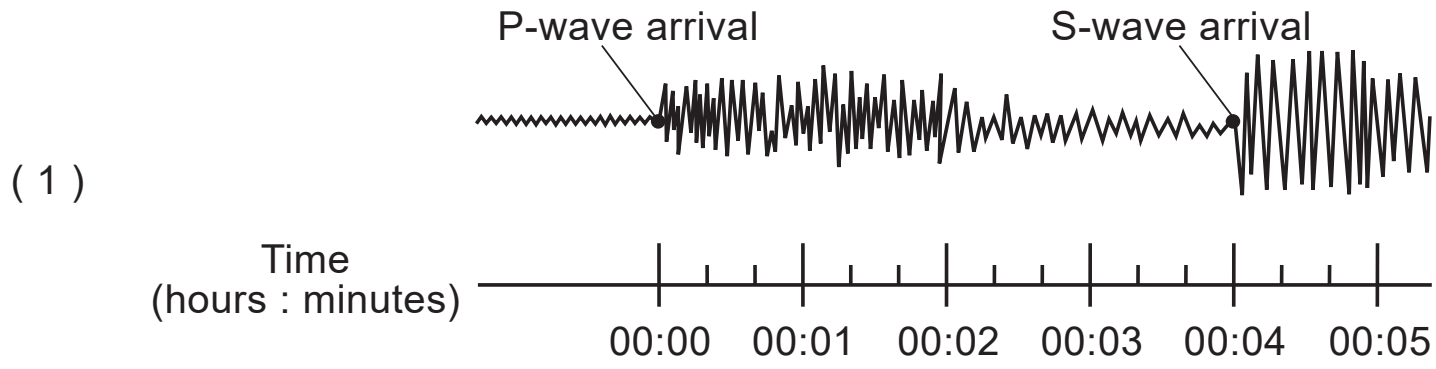

Question 32 is continued on the next page.

Question 32 is continued

(3)

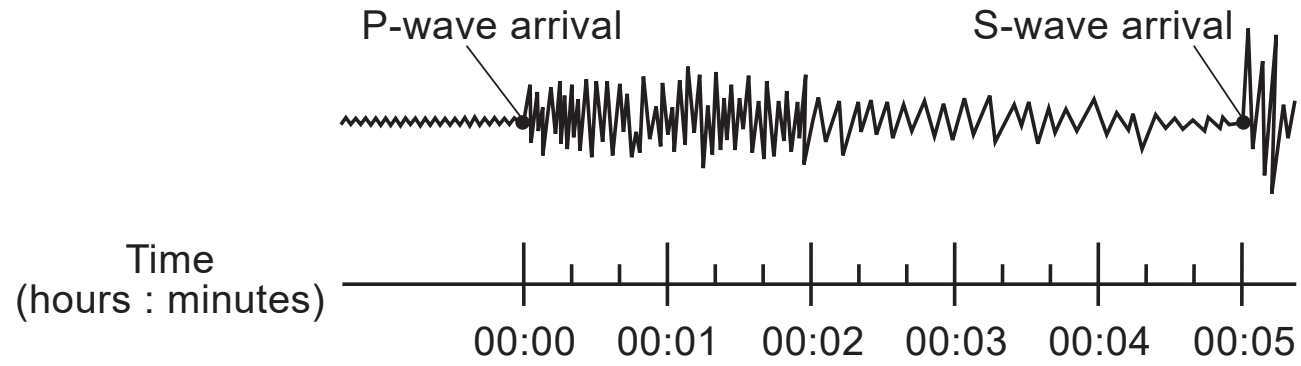

(4)

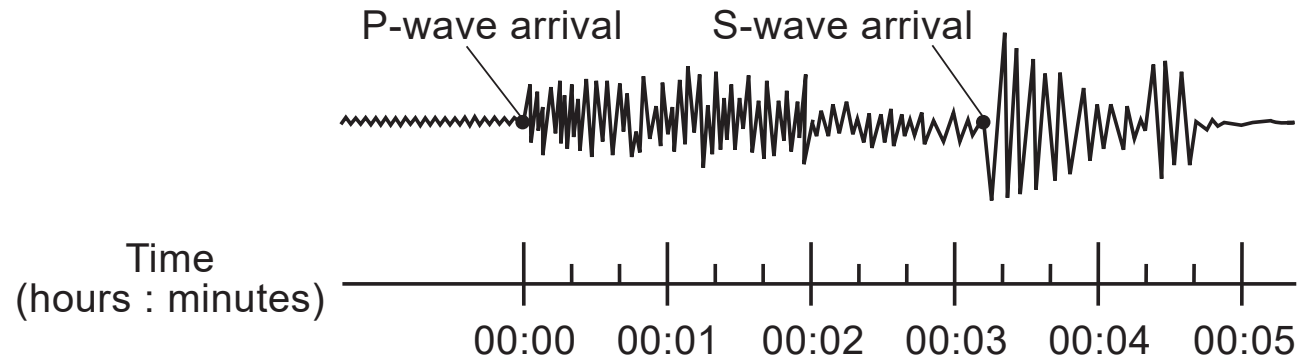

33 The topographic map below shows the path of a river. Points *A* through *E* are locations in the river.

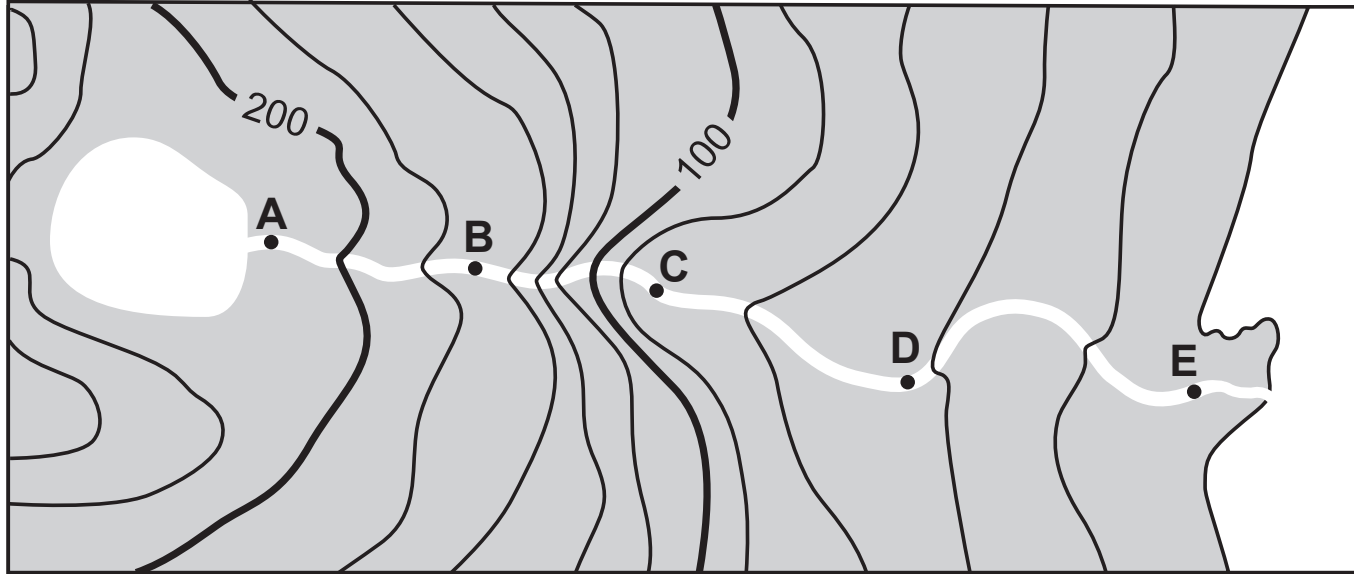

Between which two points is the river flowing the fastest?

- (1) *A* and *B*
- (2) *B* and *C*

- (3) *C* and *D*
- (4) *D* and *E*

34 The diagrams below represent landscapes in regions A and B.

Region A

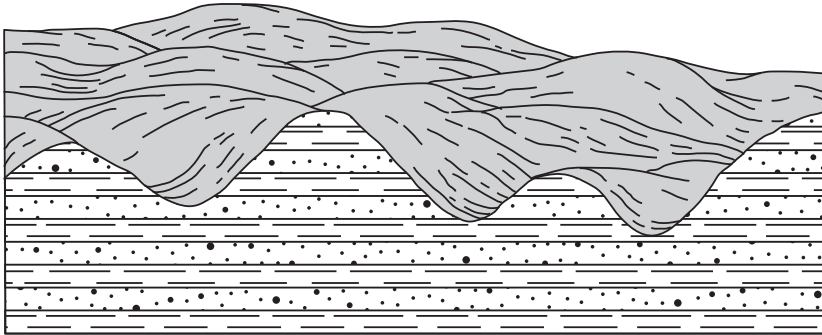

Region B

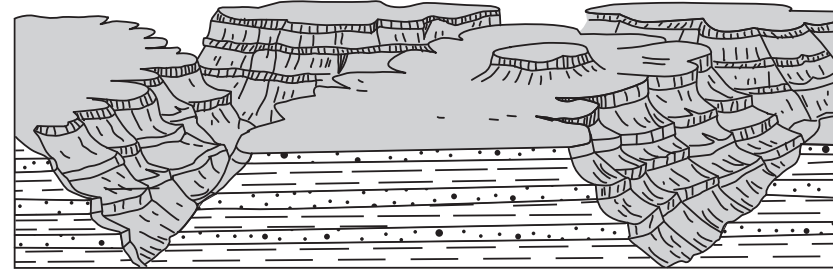

Which chart best summarizes the landscape type and climate of regions A and B?

	Region A	Region B
Landscape Type	mountain	mountain
Climate	humid	arid

(1)

	Region A	Region B
Landscape Type	plateau	plateau
Climate	humid	arid

(3)

	Region A	Region B
Landscape Type	mountain	mountain
Climate	arid	humid

(2)

	Region A	Region B
Landscape Type	plateau	plateau
Climate	arid	humid

(4)

35 The map below shows a coastal landscape feature, labeled X, that resulted from wave action and offshore currents parallel to the coastline.

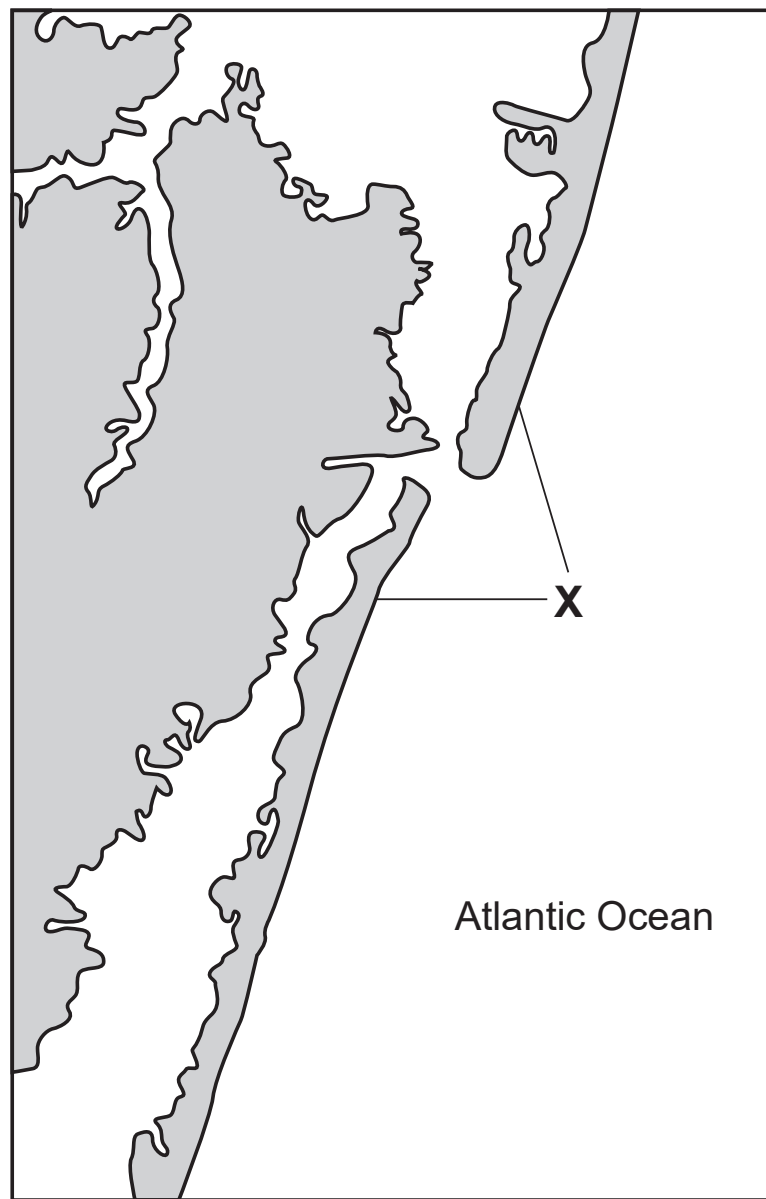

Question 35 is continued on the next page.

Question 35 is continued

Which landscape feature is represented by X?

(1) moraines

(2) drumlins

(3) barrier islands

(4) sand dunes

GO RIGHT ON TO THE NEXT PAGE ⇒

Part B-1

Answer all questions in this part.

Directions (36–50): For each statement or question, choose the word or expression that, of those given, best completes the statement or answers the question. Some questions may require the use of the 2011 Edition Reference Tables for Physical Setting/Earth Science. Record your answers on your separate answer sheet.

Base your answers to questions 36 and 37 on the passage below and on your knowledge of Earth science.

Hurricane Sandy

Hurricane Sandy was one of the most severe hurricanes to affect the northeastern United States in many years. On October 29, 2012, this storm made landfall in New Jersey. It produced a 14-foot storm surge, which is a rise in the level of ocean water along a coast caused by strong winds and low air pressure. The Moon also enhanced the effects of this storm surge, since the Moon was in full phase at the time Hurricane Sandy made landfall. During a full Moon, above-normal high tides occur on Earth.

- 36 What was the surface wind circulation pattern around the center of Hurricane Sandy?
- | | |
|----------------------------------|---------------------------|
| (1) counterclockwise and outward | (3) clockwise and outward |
| (2) counterclockwise and inward | (4) clockwise and inward |
- 37 Which air temperature and moisture characteristics are associated with the source region over which Hurricane Sandy formed?
- | | |
|--------------------|--------------------|
| (1) cool and dry | (3) warm and dry |
| (2) cool and moist | (4) warm and moist |

This page left blank intentionally.

GO RIGHT ON TO THE NEXT PAGE ⇒

Base your answers to questions 38 and 39 on the diagram below and on your knowledge of Earth science. The diagram represents a model of a portion of our solar system.

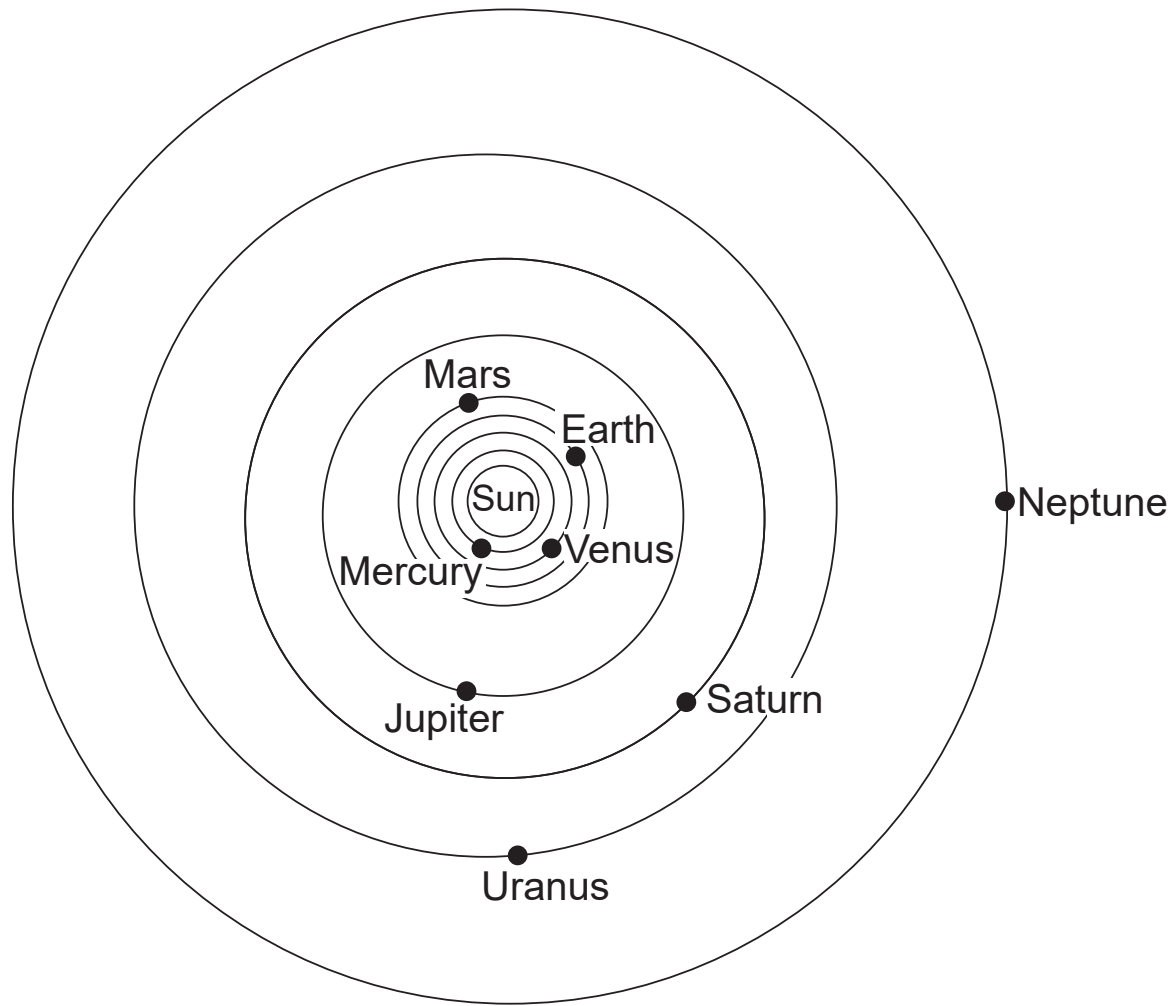

(Not drawn to scale)

38 In our solar system, the orbits of the planets are best described as

- | | |
|--|--|
| (1) elliptical with the Sun at one focus | (3) circular with the Sun at one focus |
| (2) elliptical with Earth at one focus | (4) circular with Earth at one focus |

39 Which planet takes approximately twice as long as Earth to complete one revolution around the Sun?

- | | |
|-----------|-------------|
| (1) Venus | (3) Jupiter |
| (2) Mars | (4) Saturn |
-

GO RIGHT ON TO THE NEXT PAGE ⇒

Base your answers to questions 40 and 41 on the diagram below and on your knowledge of Earth science. The diagram of Earth shows the longitude lines that are used to determine time zones.

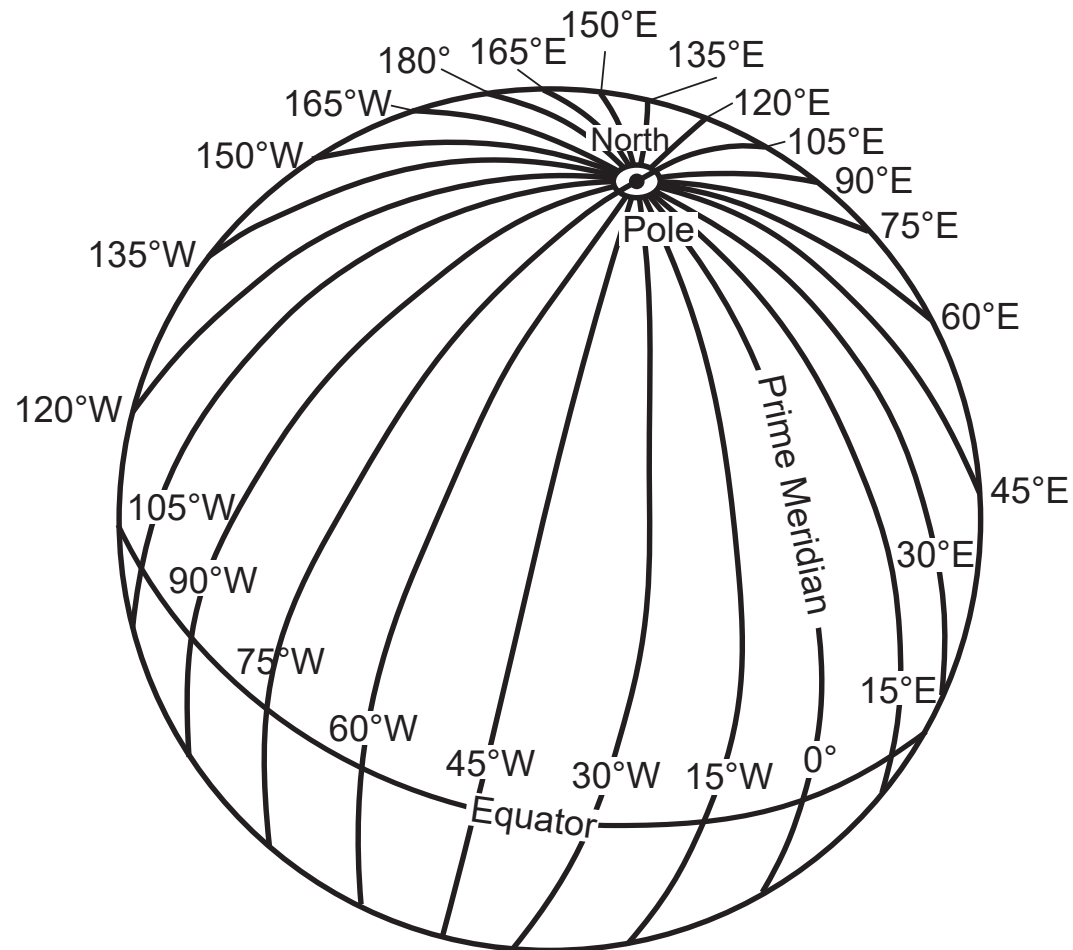

40 Which longitude line passes through New York State?

(1) 45° W

(3) 75° W

(2) 45° E

(4) 75° E

41 What is the time at 30° W when it is 7:00 a.m. at 30° E?

(1) 1:00 p.m.

(3) 3:00 a.m.

(2) 7:00 p.m.

(4) 11:00 a.m.

GO RIGHT ON TO THE NEXT PAGE \Rightarrow

Base your answers to questions 42 through 45 on the cross section below and on your knowledge of Earth science. Letters *A* through *E* represent rock units. Letter *F* represents a geologic feature. Some layers contain index fossils.

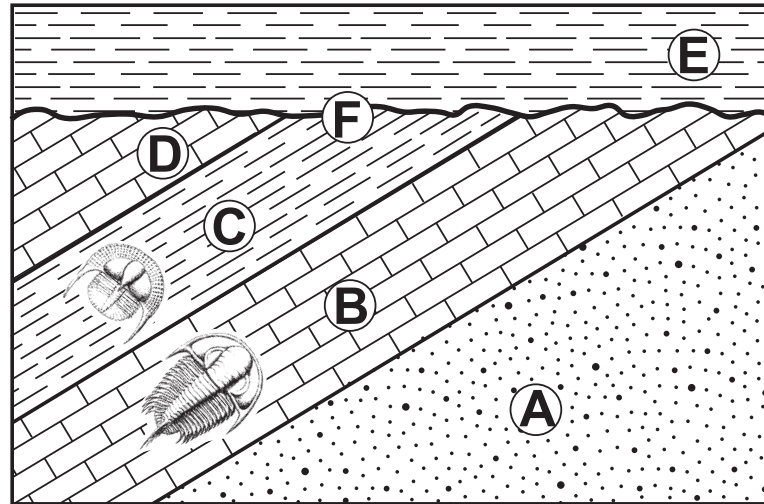

- 42 Which geologic principle could be used to support the inference that rock layers *A* through *D* experienced crustal movement?
- (1) original horizontality
(2) crosscutting relationships
(3) superposition
(4) contact metamorphism
- 43 During the Ordovician Period when layer *C* was forming, most of the United States was inferred to be located
- (1) slightly north of the equator
(2) slightly south of the equator
(3) at the North Pole
(4) at the South Pole

- 44 The geologic feature represented by letter *F* is most likely a
- (1) buried erosional surface
 - (2) contact metamorphic surface
 - (3) meteoritic debris layer
 - (4) volcanic ash layer
- 45 Carbon-14 was *not* used to date the trilobite fossils represented in the cross section because these trilobites
- (1) were never living organisms
 - (2) were buried too deep
 - (3) lived too long ago
 - (4) became extinct
-

GO RIGHT ON TO THE NEXT PAGE ⇒

Base your answers to questions 46 and 47 on the block diagram below and on your knowledge of Earth science. The diagram represents the water cycle. Letters *A* through *F* represent water cycle processes. The water table has been labeled.

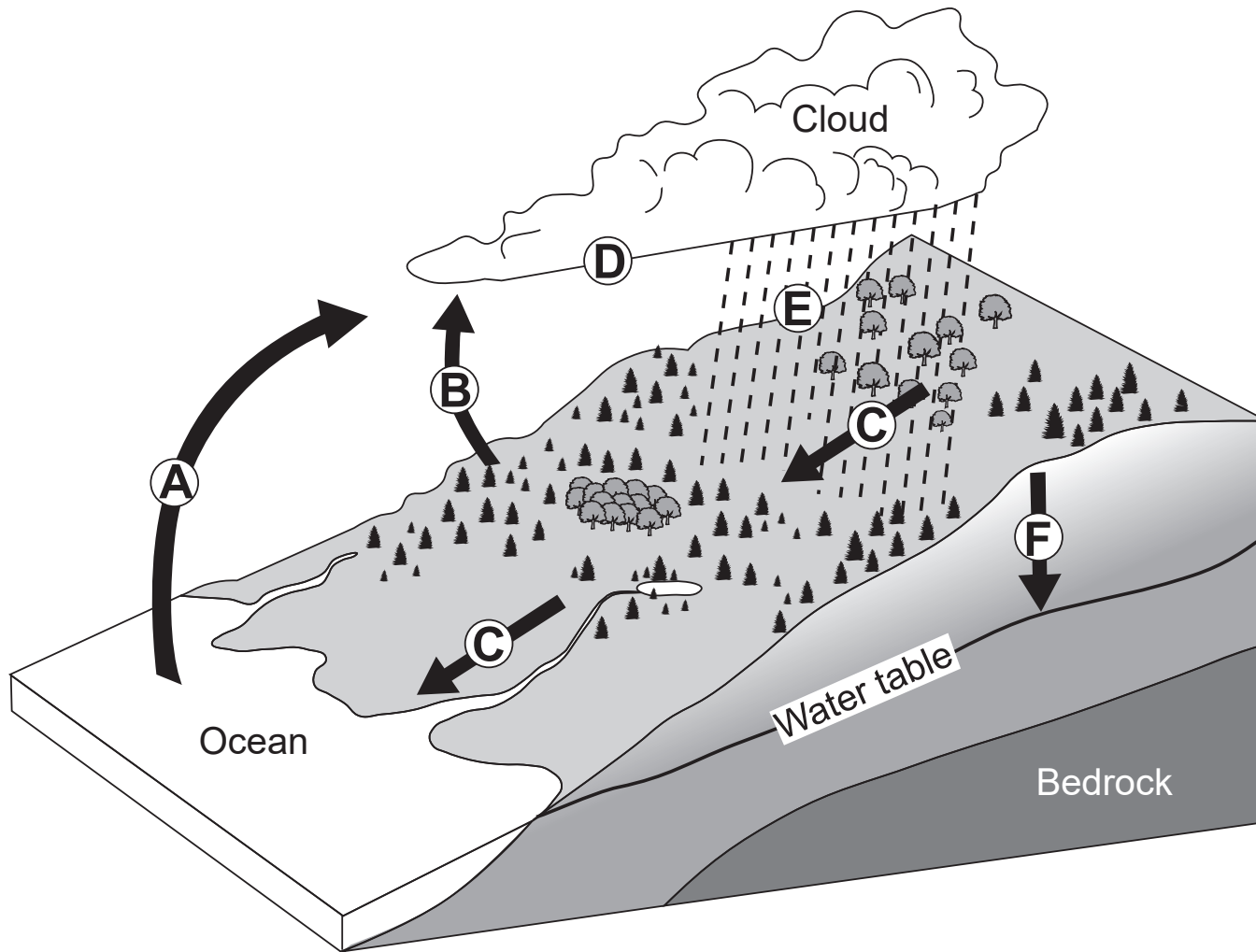

46 Which water cycle process releases 2260 joules of heat energy per gram of water?

- (1) *A*
- (2) *E*

- (3) *F*
- (4) *D*

47 Which diagram would most likely represent the height of the water table if processes *E* and *F* increased?

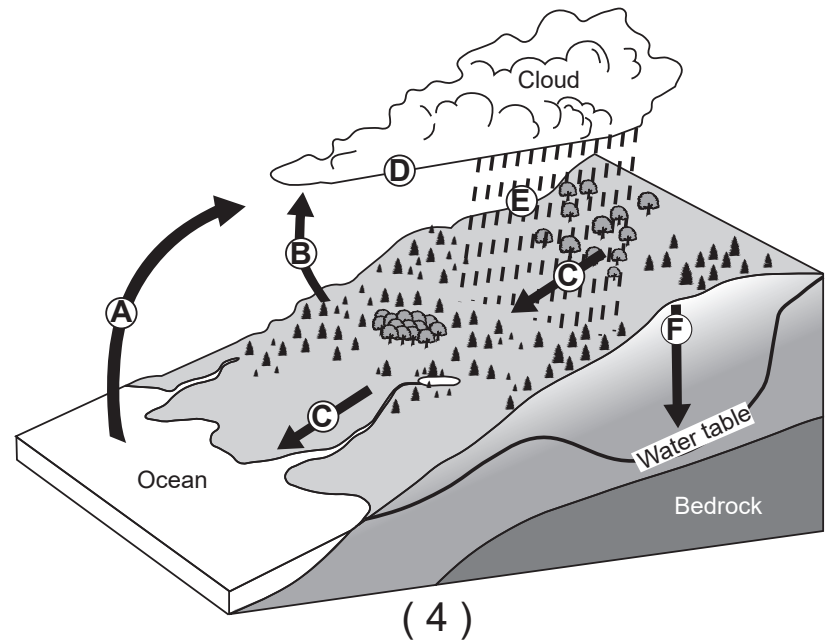
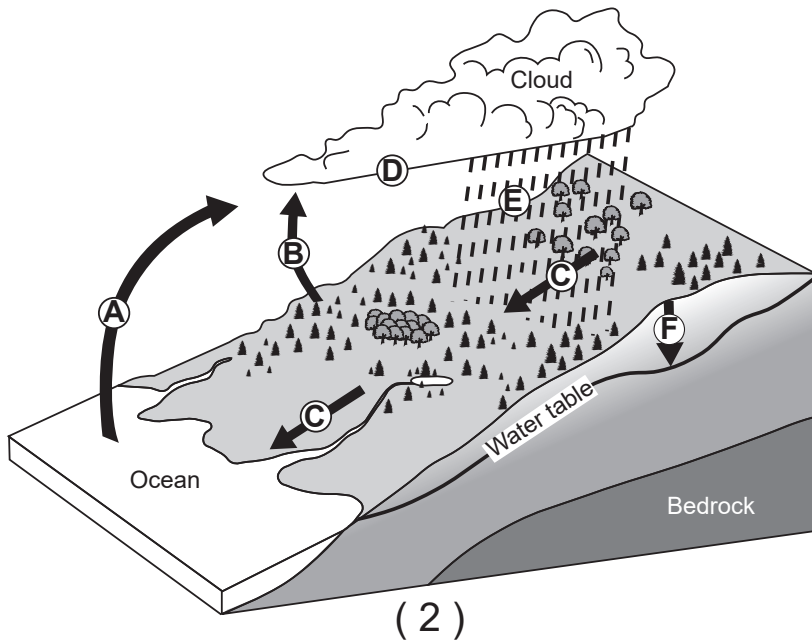
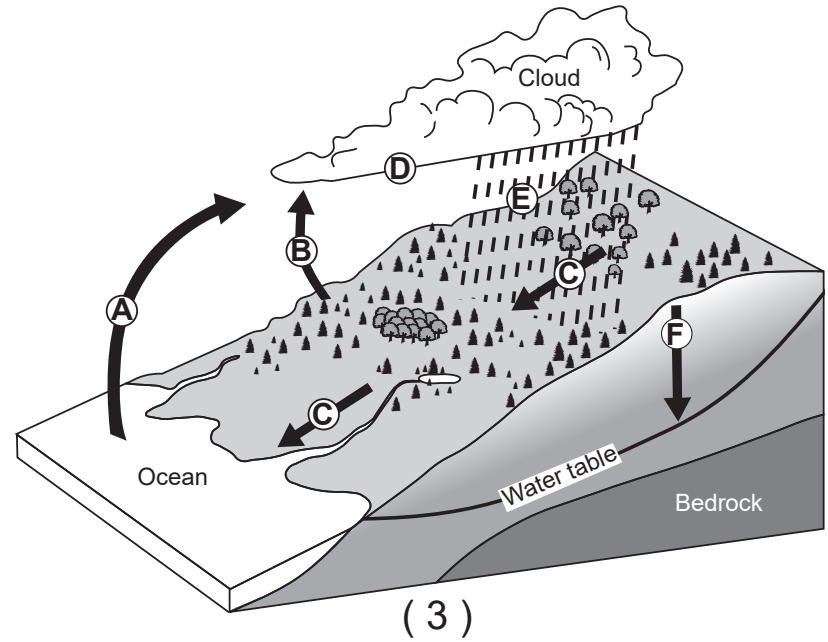
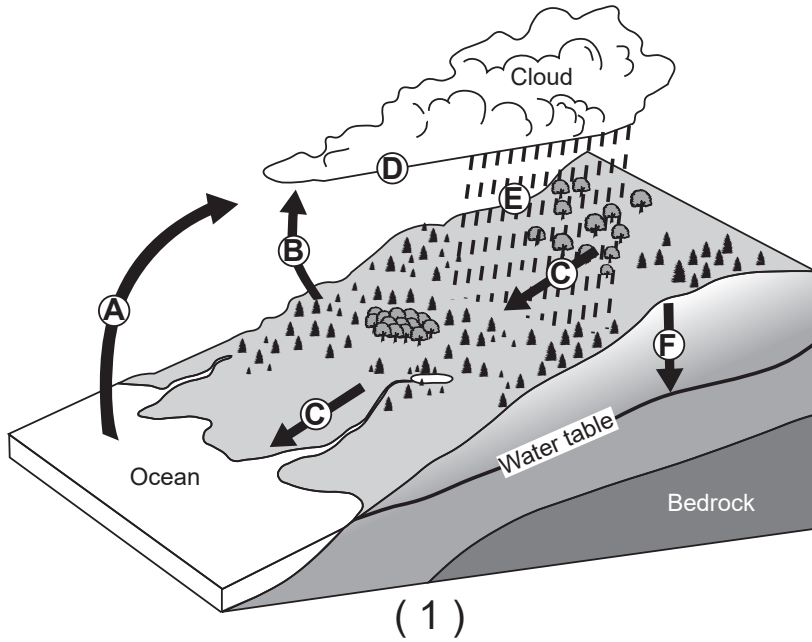

Base your answers to questions 48 through 50 on the diagram below and on your knowledge of Earth science. The diagram represents insolation received on four Earth land surfaces at locations *A*, *B*, *C*, and *D*.

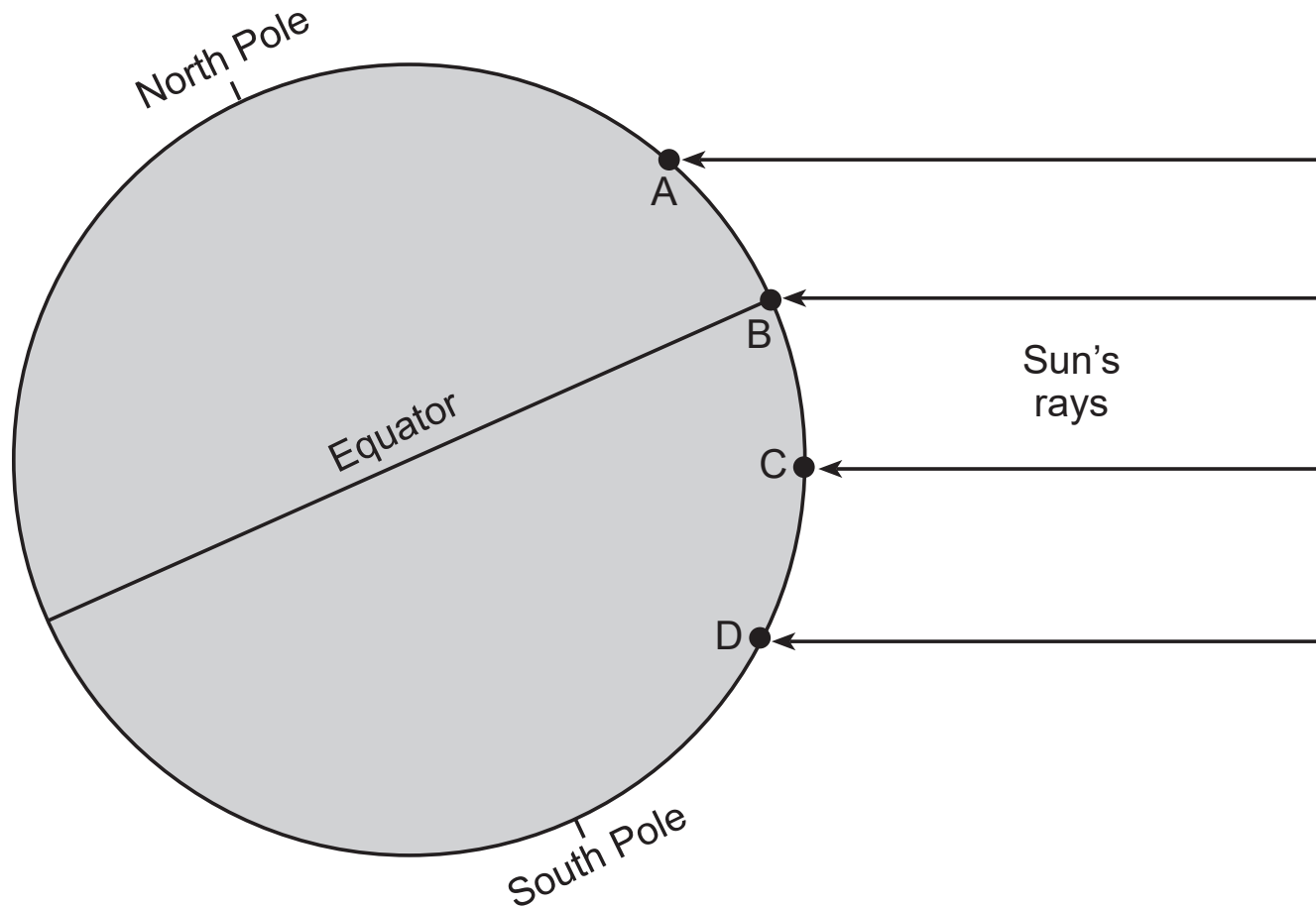

(Not drawn to scale)

48 Which location is receiving direct rays from the Sun?

(1) *A*

(2) *B*

(3) *C*

(4) *D*

- 49 Equal areas of which type of land surface usually absorb the most insolation and reflect the *least* insolation?
- (1) light-colored and smooth
 - (2) light-colored and rough
 - (3) dark-colored and smooth
 - (4) dark-colored and rough
- 50 Most of the energy radiated by these land surfaces into space is in the form of
- (1) gamma rays
 - (2) infrared
 - (3) ultraviolet
 - (4) visible light
-

GO RIGHT ON TO THE NEXT PAGE ⇒

Part B–2

Answer all questions in this part.

Directions (51–65): Record your answers in the spaces provided in your answer booklet. Some questions may require the use of the *2011 Edition Reference Tables for Physical Setting/Earth Science*.

Base your answers to questions 51 through 53 on the passage and the data table below and on your knowledge of Earth science. The data table shows the percentage of quarries in New York State that mine specific types of bedrock to produce crushed stone. A quarry is an area where rock material is removed.

Crushed Stone in New York State

Crushed stone is any bedrock that has been broken into smaller, irregularly shaped fragments. The fragment sizes can range from silt to boulders. The smallest sizes could be used to make concrete and cement while the largest could be used to line a river bank to prevent stream erosion. Although some crushed stone is used in agriculture, most is used in the building and construction industry. Shale, a common rock found in New York State, is rarely mined because it tends to weather too easily to be used as a construction material.

Crushed Stone Production in New York State

Type of Bedrock Mined	Percentage of Quarries (%)
dolostone	14
granite and gneiss	6
limestone	46
sandstone	11
slate and marble	4
all others	19

- 51 Explain why shale is rarely used in the building and construction industry. [1]
- 52 In the building and construction industry, rock sold as granite might actually be gneiss. Identify *one* observable property of gneiss that could be used to distinguish it from granite. [1]
- 53 Identify *one* mineral found in crushed sandstone that is used to make glass in the building and construction industry. [1]
-

GO RIGHT ON TO THE NEXT PAGE ⇨

Base your answers to questions 54 through 58 on the graph below and on your knowledge of Earth science. The graph shows the predicted distance of five nearby stars in our galaxy in relation to our Sun over the next 60,000 years (y). Distance is represented in light-years (ly) from the Sun. One light-year is the distance light travels in one year.

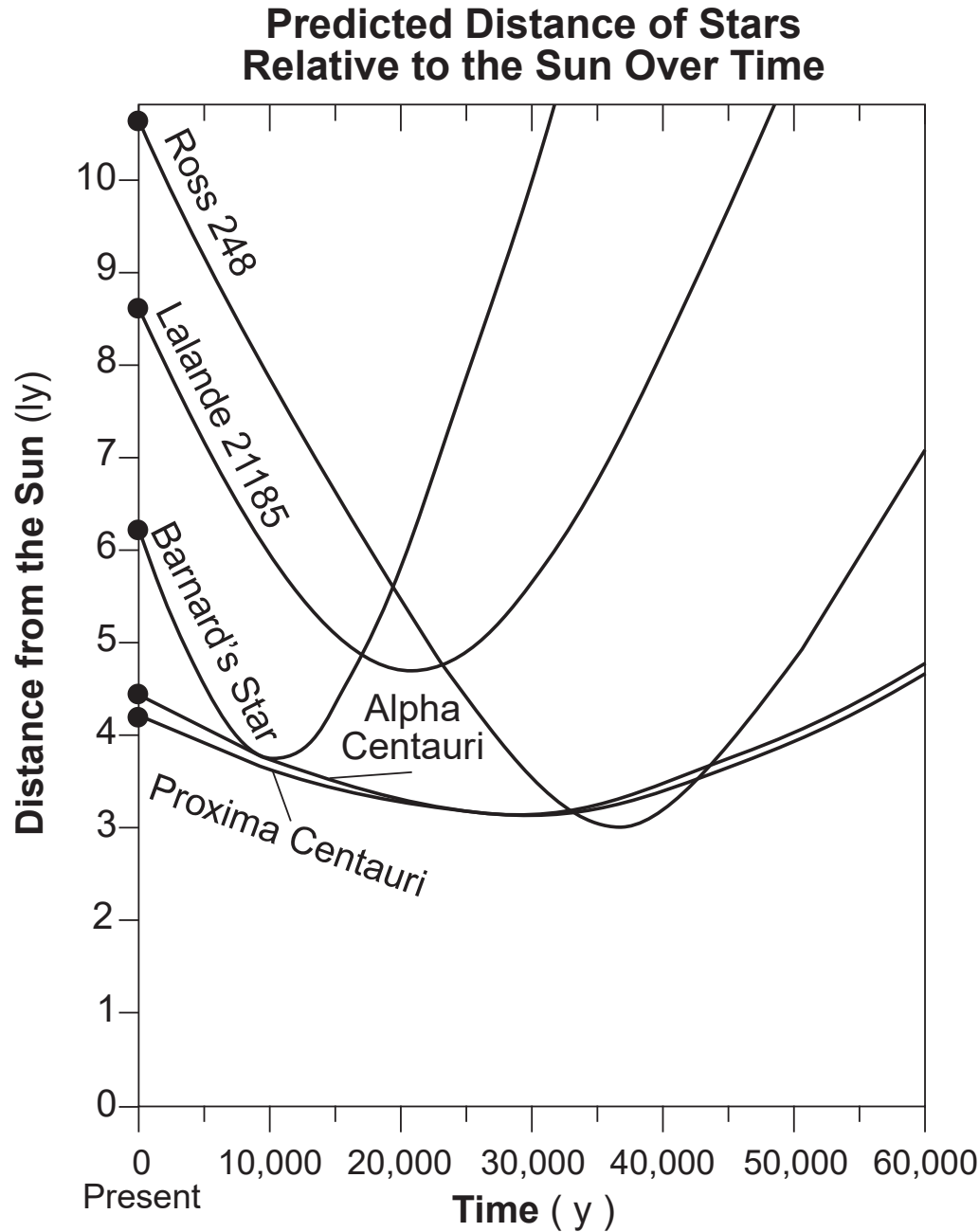

- 54 Determine the approximate present-day distance, in light-years, from the Sun to Lalande 21185. [1]
- 55 Identify the star that will show a redshift in its wavelengths of light as viewed from Earth 15,000 years from the present. [1]
- 56 At present, Proxima Centauri is the closest star to our Sun. However, Alpha Centauri is more easily visible in the night sky. *In your answer booklet*, circle the relative luminosity and relative mass of Alpha Centauri compared with the luminosity and mass of Proxima Centauri. [1]
- 57 State the name of the galaxy in which all of these stars are located. [1]
- 58 Identify the nuclear process that produces most of the energy released from all of these stars. [1]
-

GO RIGHT ON TO THE NEXT PAGE ⇒

Base your answers to questions 59 and 60 on the station model below and on your knowledge of Earth science. The station model indicates weather conditions at Albany, New York.

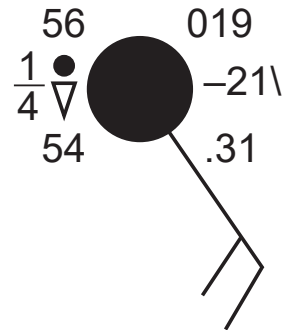

- 59 In the table *in your answer booklet*, identify the numerical value of the data on the station model measured by each weather instrument given. Include units with your answer. [1]
- 60 Based on data from the station model, explain how a scientist could infer that there was a high relative humidity in Albany. [1]
-

Base your answers to questions 61 through 65 on the passage and the map of Alaska below, on the partial isoline map in your answer booklet, and on your knowledge of Earth science. The map of Alaska shows the region from where the isoline map is taken. The isoline map shows the uplift (increase in elevation), in millimeters per year (mm/y), that has occurred for an area in southeastern Alaska. Some isolines have been drawn on the map. Letter A represents a surface location.

Alaskan Rebound

The fastest measured rates of uplift on Earth today are in southeast Alaska. Scientists first hypothesized that the cause of this uplift may have been due to tectonic forces, since this region of Alaska is located on a plate boundary where mountain building occurred. Scientists now hypothesize there is another factor causing the uplift of this region. They determined that, during the last ice age, the weight of mountain glaciers caused Earth's lithosphere to sink lower into the plastic mantle. As atmospheric greenhouse gases increased, the climate changed, causing these glaciers to melt. The lost weight of glacial ice on the lithosphere allowed the crust to rebound and float higher on the plastic mantle below, thus increasing land surface elevations. This phenomenon is called glacial rebound and accounts for the continued uplift rates seen on the rebound map on your answer sheet.

GO RIGHT ON TO THE NEXT PAGE ➡

Alaska Map

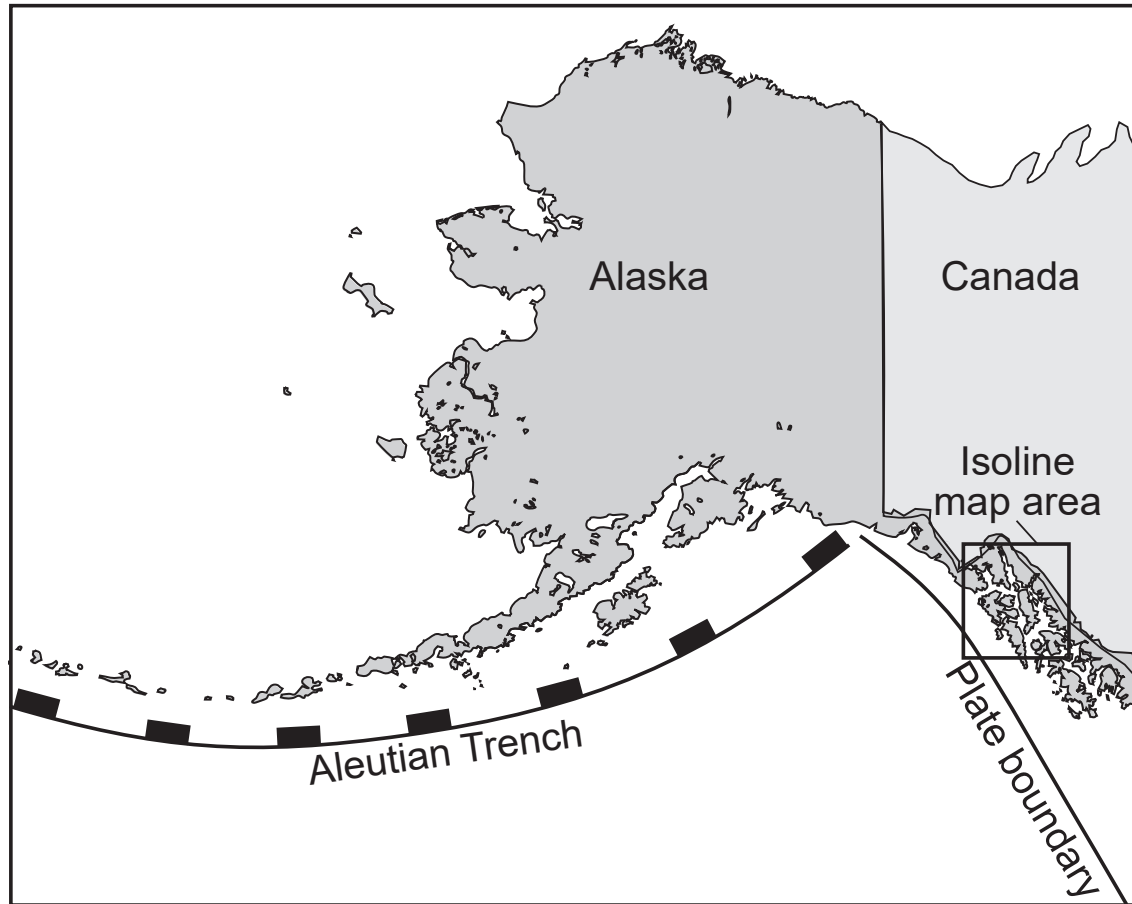

- 61 On the map *in your answer booklet*, draw the 8 mm/y and the 12 mm/y isolines. Extend the isolines to the edge of the map or the edge of the land area. [1]
- 62 The greatest rate of uplift occurred around location A. State *one* possible value, in millimeters/year (mm/y), for location A. [1]
- 63 Identify the name of the plastic mantle layer into which the lithosphere sank due to the weight of the mountain glaciers. [1]
- 64 Identify the names of the *two* tectonic plates that are on either side of the two plate boundaries that are located within the area shown on the Alaska map. [1]
- 65 Identify *two* major greenhouse gases that contribute to climate change and the melting of these Alaskan glaciers. [1]
-

Part C

Answer all questions in this part.

Directions (66–85): Record your answers in the spaces provided in your answer booklet. Some questions may require the use of the *2011 Edition Reference Tables for Physical Setting/Earth Science*.

Base your answers to questions 66 through 69 on the diagram in your answer booklet and on your knowledge of Earth science. The diagram represents three apparent paths of the Sun, labeled *A*, *B*, and *C*, on the first day of each season, as seen by an observer at Binghamton, New York. The Sun's position on path *B* indicates a specific time of day. Compass directions are indicated along the horizon.

- 66 On the diagram *in your answer booklet*, draw the path of the Sun for November 5. The line representing the Sun's path must begin and end on the horizon. [1]
- 67 Describe how the length of the observer's shadow changes from sunrise to sunset as the Sun appears to travel along path *A*. [1]
- 68 Identify the time of day indicated by the Sun's position on path *B*. Indicate a.m. or p.m. in your response. [1]
- 69 *In your answer booklet*, circle the relative intensity of insolation and the relative duration of insolation of the Sun for path *C* compared to the intensity and duration of insolation of the Sun for path *B*. [1]
-

Base your answers to questions 70 through 72 on the diagram below and on your knowledge of Earth science. The diagram represents a specific New York State index fossil that is a member of a group of extinct marine animals called eurypterids.

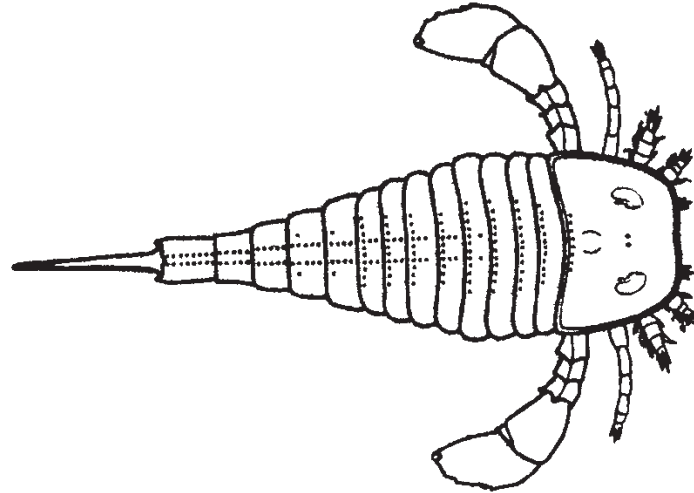

- 70 Identify the geologic period of the bedrock in which this specific New York State index fossil can be found. [1]
- 71 Describe *one* characteristic necessary for this fossil to be classified as an index fossil. [1]
- 72 Infer the past environment that existed at a New York State location where eurypterid fossils have been discovered in the bedrock. [1]
-

Base your answers to questions 73 through 75 on the passage below and on your knowledge of Earth science.

A Geologist's Tour of New York City

When taking a tour of New York City, one can find many geologic points of interest at locations such as Federal Plaza, Wall Street, Foley Square, and Central Park.

Federal Plaza: These buildings contain granite from Avalon, a small continent that was once attached to our east coast when Africa, Europe, and North America pulled apart.

Wall Street: Some buildings contain stone that comes from Morocco in North Africa and contains coral fossils. The same 370-million-year-old coral fossils are also found in some New York State surface bedrock.

Foley Square: A building here is made of limestone that came from Indiana, a region that was a sea floor during the Pennsylvanian Period.

Central Park: The exposed bedrock is schist, and is what remains of an ancient mountain that stood 15,000 feet high. This mountain formed from ocean-bottom mud that was heated, squeezed, and folded upward under pressure.

- 73 *In your answer booklet*, circle either felsic or mafic to indicate the composition of the rock at Federal Plaza and list *two* minerals likely to be found in this rock. [1]
- 74 Identify the New York State landscape region where the surface bedrock most likely contains the same coral fossils as the ones found in Morocco. [1]
- 75 Explain how the 15,000-foot-high ancient mountain was reduced to small hills in today's Central Park. [1]
-

Base your answers to questions 76 through 79 on the map below and on your knowledge of Earth science. The map shows a portion of Earth's Tectonic Plates map from the 2011 Edition Reference Tables for Physical Setting/Earth Science. The arrows represent relative crustal plate movement. Letters A, B, C, D, E, F, G, and H represent locations on Earth's surface.

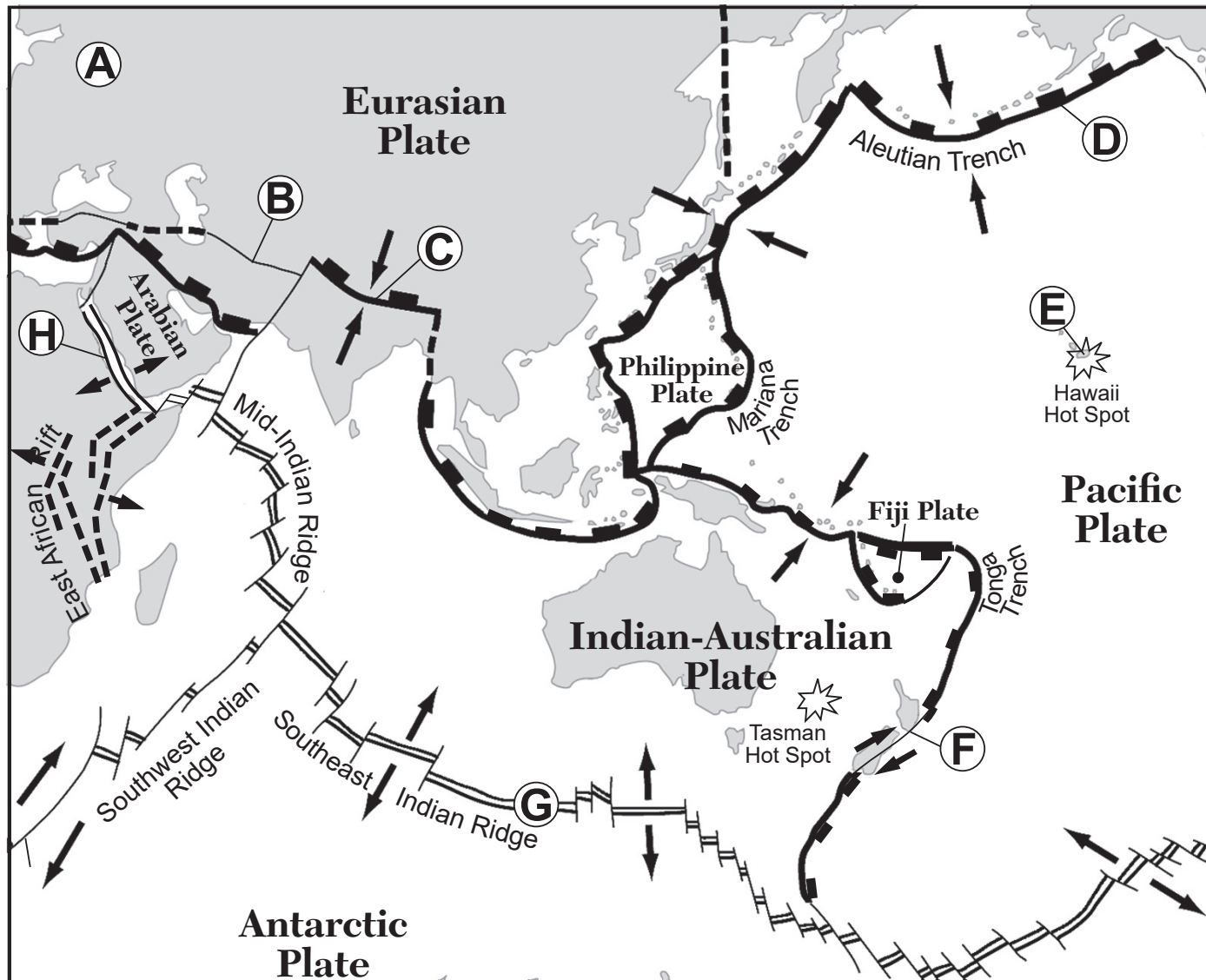

- 76 Identify the *two* letters that indicate locations on transform plate boundaries. [1]
- 77 Explain why earthquakes are more likely to occur near location *H* than near location *A*. [1]
- 78 Scientists infer that the magma that formed the hot spot at location *E* originates at the boundary between the stiffer mantle and the outer core. Determine the depth, in kilometers, below Earth's surface where the boundary between the stiffer mantle and the outer core is located. [1]
- 79 State the name and the density of the igneous rock found at the surface of the Pacific Ocean crust. [1]
-

Base your answers to questions 80 through 82 on the map in your answer booklet and on your knowledge of Earth science. The map shows a stream and its tributary. Letters *A* and *B* are locations in the stream. The arrows indicate the direction of streamflow.

- 80 On the map *in your answer booklet*, draw an **X** along the streambank where erosion is most likely greater than deposition. [1]
- 81 The velocity of the stream was determined to be greater at location *B* than at location *A*. State *one* possible reason why the stream velocity was greater at location *B*. [1]
- 82 Describe *one* change that would occur to an angular pebble as it is transported by this stream for a longer period of time. [1]
-

Base your answers to questions 83 through 85 on the map below, the data table on the next page, and on your knowledge of Earth science. The map shows the location of the Atacama and Patagonia deserts in relation to the Andes Mountains in South America. The cities of Antofagasta, Chile, and La Junta, Argentina, are shown. The data table shows the average monthly high air temperatures for Antofagasta and La Junta.

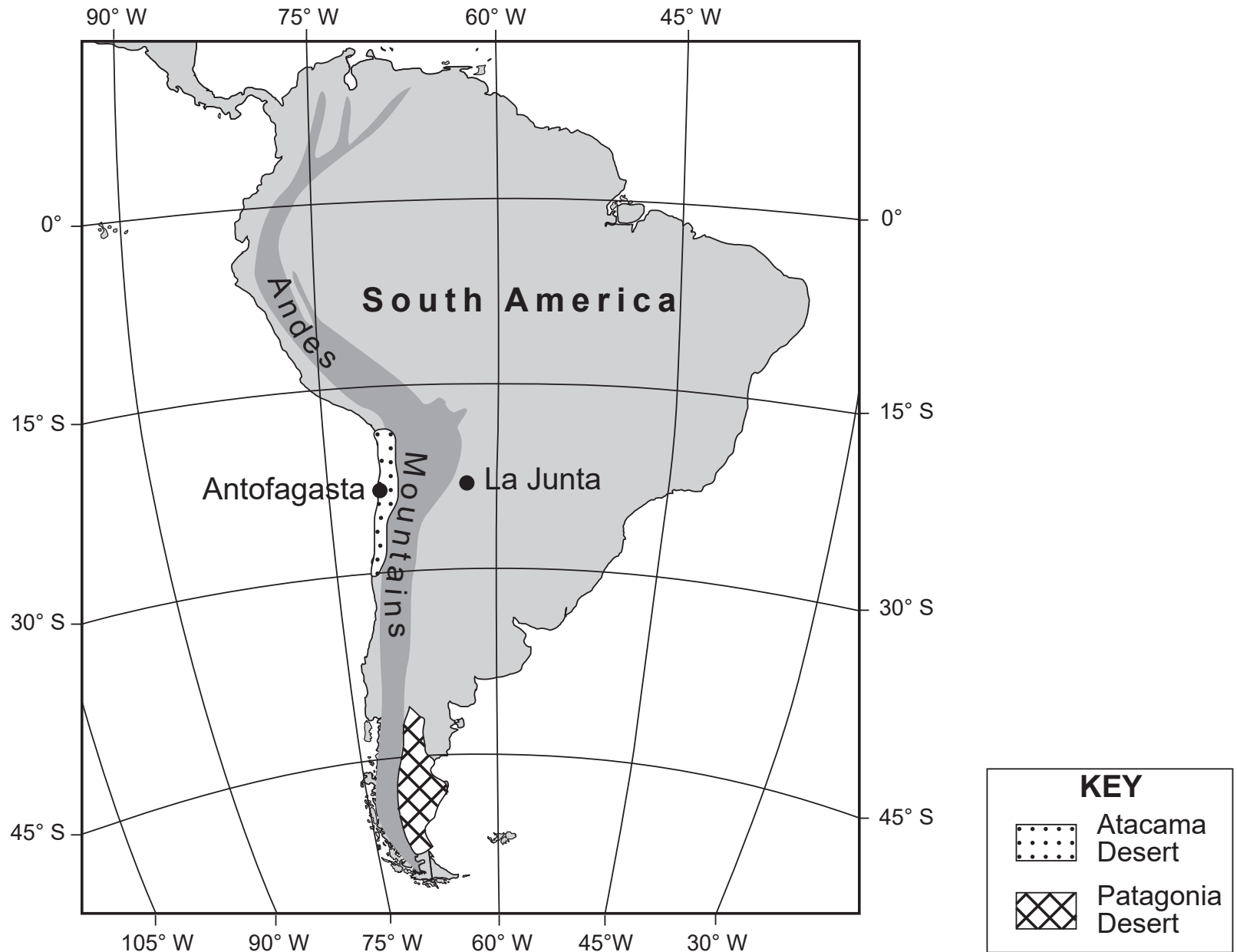

Average Monthly High Air Temperatures

Month	Antofagasta Air Temperature (°C)	La Junta Air Temperature (°C)
January	24	29
February	24	28
March	23	25
April	21	20
May	19	16
June	18	13
July	17	13
August	17	15
September	18	17
October	19	22
November	20	25
December	22	28

83 On the graph *in your answer booklet*, construct a line graph by plotting the average monthly high air temperature for La Junta, Argentina, for each month listed on the data table. Connect the plots with a line. The average monthly high air temperatures for Antofagasta, Chile, have already been plotted on the graph. [1]

84 State *one* reason Antofagasta, Chile, has a smaller yearly temperature range than La Junta, Argentina. [1]

85 Explain why both Antofagasta and La Junta have their coolest air temperatures for the year in June, July, and August, and their warmest air temperatures for the year in December, January, and February. [1]

