

The University of the State of New York
REGENTS HIGH SCHOOL EXAMINATION

**PHYSICAL SETTING
PHYSICS**

Tuesday, June 22, 2010 — 9:15 a.m. to 12:15 p.m., only

The answers to *all* questions in this examination are to be written in your separate answer booklet. Be sure to fill in the heading on the front of your answer booklet.

You are to answer all questions in all parts of this examination according to the directions provided in the examination booklet. All work should be written in pen, except for graphs and drawings, which should be done in pencil. You may use scrap paper to work out the answers to the questions, but be sure to record all your answers in the answer booklet.

When you have completed the examination, you must sign the statement printed on the first page of your answer booklet, indicating that you had no unlawful knowledge of the questions or answers prior to the examination and that you have neither given nor received assistance in answering any of the questions during the examination. Your answer booklet cannot be accepted if you fail to sign this declaration.

Notice. . .

A scientific or graphing calculator, a centimeter ruler, a protractor, and a copy of the *2006 Edition Reference Tables for Physical Setting/Physics*, which you may need to answer some questions in this examination, must be available for your use while taking this examination.

The use of any communications device is strictly prohibited when taking this examination. If you use any communications device, no matter how briefly, your examination will be invalidated and no score will be calculated for you.

DO NOT OPEN THIS EXAMINATION BOOKLET UNTIL THE SIGNAL IS GIVEN.

Part A

Answer all questions in this part.

Directions (1–35): For *each* statement or question, write in your answer booklet the *number* of the word or expression that, of those given, best completes the statement or answers the question.

1 A baseball player runs 27.4 meters from the batter's box to first base, overruns first base by 3.0 meters, and then returns to first base. Compared to the total distance traveled by the player, the magnitude of the player's total displacement from the batter's box is

- (1) 3.0 m shorter (3) 3.0 m longer
(2) 6.0 m shorter (4) 6.0 m longer

2 A motorboat, which has a speed of 5.0 meters per second in still water, is headed east as it crosses a river flowing south at 3.3 meters per second. What is the magnitude of the boat's resultant velocity with respect to the starting point?

- (1) 3.3 m/s (3) 6.0 m/s
(2) 5.0 m/s (4) 8.3 m/s

3 A car traveling on a straight road at 15.0 meters per second accelerates uniformly to a speed of 21.0 meters per second in 12.0 seconds. The total distance traveled by the car in this 12.0-second time interval is

- (1) 36.0 m (3) 216 m
(2) 180. m (4) 252 m

4 A 0.149-kilogram baseball, initially moving at 15 meters per second, is brought to rest in 0.040 second by a baseball glove on a catcher's hand. The magnitude of the average force exerted on the ball by the glove is

- (1) 2.2 N (3) 17 N
(2) 2.9 N (4) 56 N

5 Which body is in equilibrium?

- (1) a satellite moving around Earth in a circular orbit
(2) a cart rolling down a frictionless incline
(3) an apple falling freely toward the surface of Earth
(4) a block sliding at constant velocity across a tabletop

6 As shown in the diagram below, a student standing on the roof of a 50.0-meter-high building kicks a stone at a horizontal speed of 4.00 meters per second.

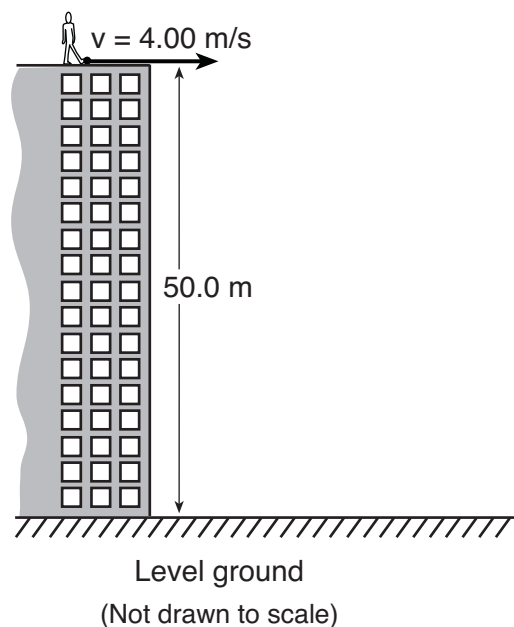

How much time is required for the stone to reach the level ground below? [Neglect friction.]

- (1) 3.19 s (3) 10.2 s
(2) 5.10 s (4) 12.5 s

7 On the surface of Earth, a spacecraft has a mass of 2.00×10^4 kilograms. What is the mass of the spacecraft at a distance of one Earth radius above Earth's surface?

- (1) $5.00 \times 10^3 \text{ kg}$ (3) $4.90 \times 10^4 \text{ kg}$
(2) $2.00 \times 10^4 \text{ kg}$ (4) $1.96 \times 10^5 \text{ kg}$

8 A student pulls a 60.-newton sled with a force having a magnitude of 20. newtons. What is the magnitude of the force that the sled exerts on the student?

- (1) 20. N (3) 60. N
(2) 40. N (4) 80. N

9 The data table below lists the mass and speed of four different objects.

Data Table

Object	Mass (kg)	Speed (m/s)
A	4.0	6.0
B	6.0	5.0
C	8.0	3.0
D	16.0	1.5

Which object has the greatest inertia?

- (1) A (3) C
 (2) B (4) D

10 The diagram below shows a horizontal 12-newton force being applied to two blocks, A and B, initially at rest on a horizontal, frictionless surface. Block A has a mass of 1.0 kilogram and block B has a mass of 2.0 kilograms.

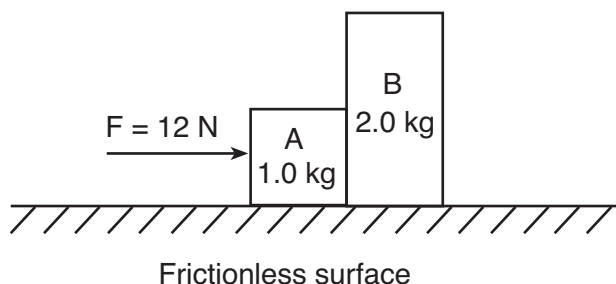

The magnitude of the acceleration of block B is

- (1) 6.0 m/s^2 (3) 3.0 m/s^2
 (2) 2.0 m/s^2 (4) 4.0 m/s^2

11 A ball is thrown vertically upward with an initial velocity of 29.4 meters per second. What is the maximum height reached by the ball? [Neglect friction.]

- (1) 14.7 m (3) 44.1 m
 (2) 29.4 m (4) 88.1 m

12 The diagram below represents a mass, m , being swung clockwise at constant speed in a horizontal circle.

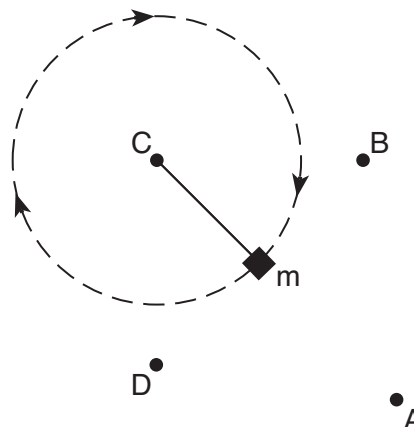

At the instant shown, the centripetal force acting on mass m is directed toward point

- (1) A (3) C
 (2) B (4) D

13 A 3.1-kilogram gun initially at rest is free to move. When a 0.015-kilogram bullet leaves the gun with a speed of 500. meters per second, what is the speed of the gun?

- (1) 0.0 m/s (3) 7.5 m/s
 (2) 2.4 m/s (4) 500. m/s

- 14 Four projectiles, *A*, *B*, *C*, and *D*, were launched from, and returned to, level ground. The data table below shows the initial horizontal speed, initial vertical speed, and time of flight for each projectile.

Data Table

Projectile	Initial Horizontal Speed (m/s)	Initial Vertical Speed (m/s)	Time of Flight (s)
A	40.0	29.4	6.00
B	60.0	19.6	4.00
C	50.0	24.5	5.00
D	80.0	19.6	4.00

Which projectile traveled the greatest horizontal distance? [Neglect friction.]

- (1) *A* (3) *C*
 (2) *B* (4) *D*
- 15 A wound spring provides the energy to propel a toy car across a level floor. At time t_i , the car is moving at speed v_i across the floor and the spring is unwinding, as shown below. At time t_f , the spring has fully unwound and the car has coasted to a stop.

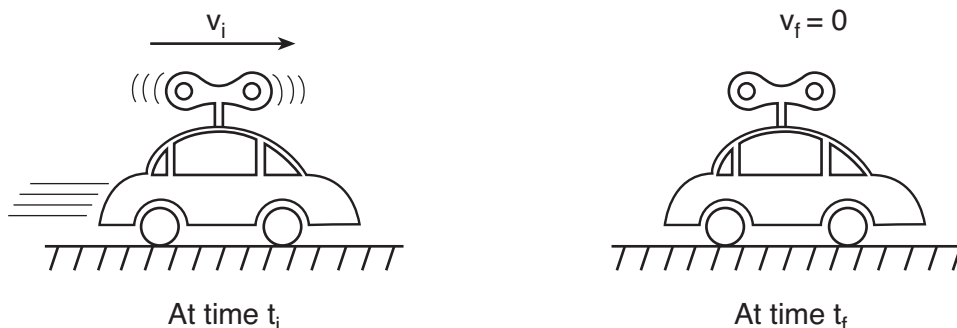

Which statement best describes the transformation of energy that occurs between times t_i and t_f ?

- (1) Gravitational potential energy at t_i is converted to internal energy at t_f .
 (2) Elastic potential energy at t_i is converted to kinetic energy at t_f .
 (3) Both elastic potential energy and kinetic energy at t_i are converted to internal energy at t_f .
 (4) Both kinetic energy and internal energy at t_i are converted to elastic potential energy at t_f .
- 16 A 75-kilogram bicyclist coasts down a hill at a constant speed of 12 meters per second. What is the kinetic energy of the bicyclist?

- (1) 4.5×10^2 J (3) 5.4×10^3 J
 (2) 9.0×10^2 J (4) 1.1×10^4 J

- 17 The diagram below represents a 155-newton box on a ramp. Applied force F causes the box to slide from point A to point B .

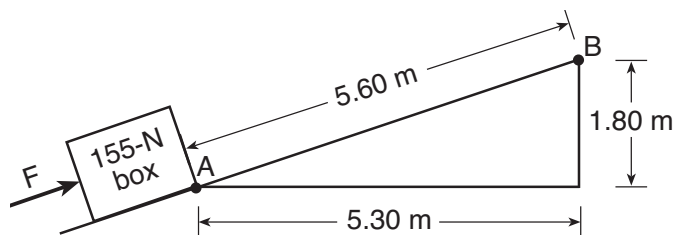

What is the total amount of gravitational potential energy gained by the box?

- (1) 28.4 J (3) 868 J
 (2) 279 J (4) 2740 J
- 18 An electric heater operating at 120. volts draws 8.00 amperes of current through its 15.0 ohms of resistance. The total amount of heat energy produced by the heater in 60.0 seconds is
- (1) 7.20×10^3 J (3) 8.64×10^4 J
 (2) 5.76×10^4 J (4) 6.91×10^6 J

- 19 Magnetic fields are produced by particles that are
- (1) moving and charged
 (2) moving and neutral
 (3) stationary and charged
 (4) stationary and neutral

- 20 A charge of 30. coulombs passes through a 24-ohm resistor in 6.0 seconds. What is the current through the resistor?
- (1) 1.3 A (3) 7.5 A
 (2) 5.0 A (4) 4.0 A

- 21 What is the magnitude of the electrostatic force between two electrons separated by a distance of 1.00×10^{-8} meter?
- (1) 2.56×10^{-22} N (3) 2.30×10^{-12} N
 (2) 2.30×10^{-20} N (4) 1.44×10^{-1} N

- 22 The diagram below represents the electric field surrounding two charged spheres, A and B .

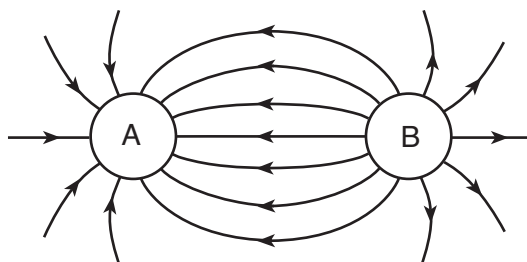

What is the sign of the charge of each sphere?

- (1) Sphere A is positive and sphere B is negative.
 (2) Sphere A is negative and sphere B is positive.
 (3) Both spheres are positive.
 (4) Both spheres are negative.
- 23 Which circuit has the *smallest* equivalent resistance?

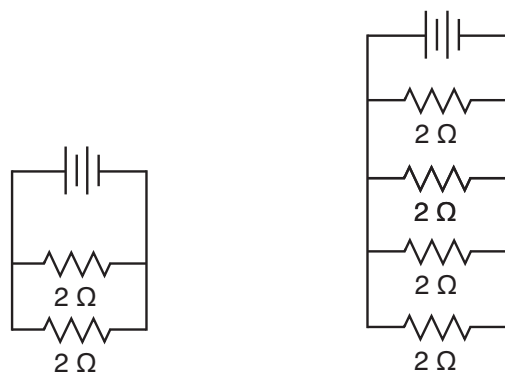

- (1) (3)

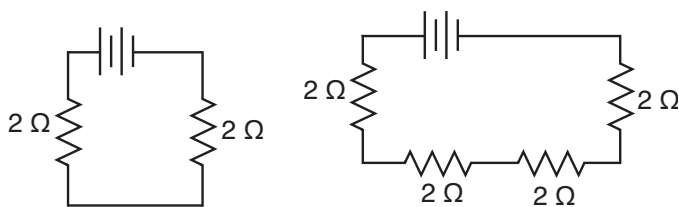

- (2) (4)

Base your answers to questions 24 through 26 on the information and diagram below.

A longitudinal wave moves to the right through a uniform medium, as shown below. Points *A*, *B*, *C*, *D*, and *E* represent the positions of particles of the medium.

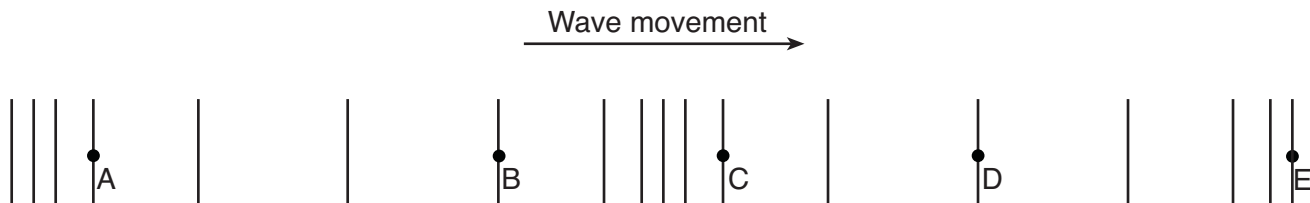

24 Which diagram best represents the motion of the particle at position *C* as the wave moves to the right?

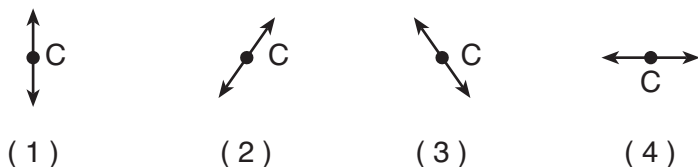

25 The wavelength of this wave is equal to the distance between points

- (1) *A* and *B*
- (2) *A* and *C*
- (3) *B* and *C*
- (4) *B* and *E*

26 The energy of this wave is related to its

- (1) amplitude
- (2) period
- (3) speed
- (4) wavelength

27 A ray of monochromatic yellow light ($f = 5.09 \times 10^{14}$ Hz) passes from water through flint glass and into medium *X*, as shown below.

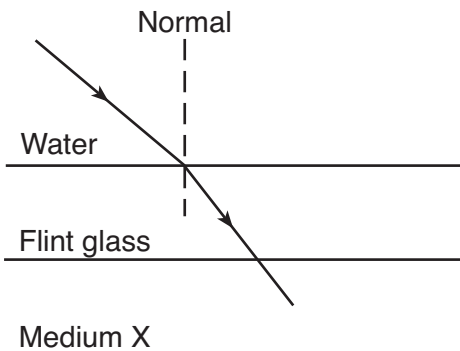

The absolute index of refraction of medium *X* is

- (1) less than 1.33
- (2) greater than 1.33 and less than 1.52
- (3) greater than 1.52 and less than 1.66
- (4) equal to 1.66

- 28 A light ray traveling in air enters a second medium and its speed slows to 1.71×10^8 meters per second. What is the absolute index of refraction of the second medium?
- (1) 1.00 (3) 1.75
(2) 0.570 (4) 1.94
- 29 Playing a certain musical note on a trumpet causes the spring on the bottom of a nearby snare drum to vibrate. This phenomenon is an example of
- (1) resonance (3) reflection
(2) refraction (4) diffraction
- 30 In a vacuum, all electromagnetic waves have the same
- (1) speed (3) frequency
(2) phase (4) wavelength
- 31 A particle that is composed of two up quarks and one down quark is a
- (1) meson (3) proton
(2) neutron (4) positron
- 32 A helium atom consists of two protons, two electrons, and two neutrons. In the helium atom, the strong force is a fundamental interaction between the
- (1) electrons, only
(2) electrons and protons
(3) neutrons and electrons
(4) neutrons and protons
- 33 What total mass must be converted into energy to produce a gamma photon with an energy of 1.03×10^{-13} joule?
- (1) 1.14×10^{-30} (3) 3.09×10^{-5}
(2) 3.43×10^{-22} (4) 8.75×10^{29}
- 34 Compared to the mass and charge of a proton, an antiproton has
- (1) the same mass and the same charge
(2) greater mass and the same charge
(3) the same mass and the opposite charge
(4) greater mass and the opposite charge
- Note that question 35 has only three choices.**
- 35 As viewed from Earth, the light from a star has lower frequencies than the light emitted by the star because the star is
- (1) moving toward Earth
(2) moving away from Earth
(3) stationary

Part B-1

Answer all questions in this part.

Directions (36–50): For *each* statement or question, write in your answer booklet the *number* of the word or expression that, of those given, best completes the statement or answers the question.

36 The total work done in lifting a typical high school physics textbook a vertical distance of 0.10 meter is approximately

- (1) 0.15 J (3) 15 J
 (2) 1.5 J (4) 150 J

37 Which electrical unit is equivalent to one joule?

- (1) volt per meter (3) volt per coulomb
 (2) ampere•volt (4) coulomb•volt

38 A small electric motor is used to lift a 0.50-kilogram mass at constant speed. If the mass is lifted a vertical distance of 1.5 meters in 5.0 seconds, the average power developed by the motor is

- (1) 0.15 W (3) 3.8 W
 (2) 1.5 W (4) 7.5 W

39 A ball is dropped from the top of a cliff. Which graph best represents the relationship between the ball's total energy and elapsed time as the ball falls to the ground? [Neglect friction.]

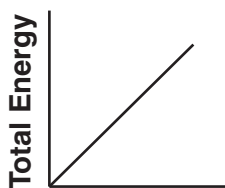

Time
(1)

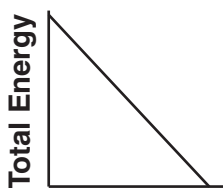

Time
(3)

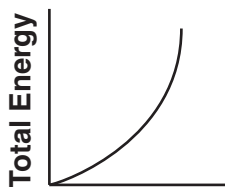

Time
(2)



Time
(4)

40 A child, starting from rest at the top of a playground slide, reaches a speed of 7.0 meters per second at the bottom of the slide. What is the vertical height of the slide? [Neglect friction.]

- (1) 0.71 m (3) 2.5 m
 (2) 1.4 m (4) 3.5 m

41 The graph below represents the relationship between the current in a metallic conductor and the potential difference across the conductor at constant temperature.

Current vs. Potential Difference

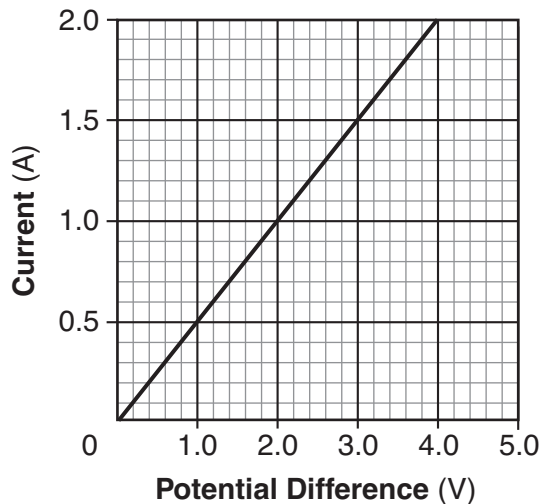

The resistance of the conductor is

- (1) 1.0 Ω (3) 0.50 Ω
 (2) 2.0 Ω (4) 4.0 Ω

42 A student throws a baseball vertically upward and then catches it. If vertically upward is considered to be the positive direction, which graph best represents the relationship between velocity and time for the baseball? [Neglect friction.]

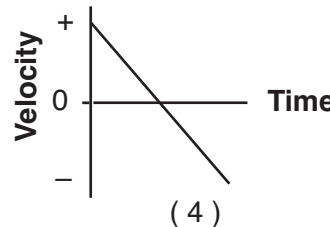
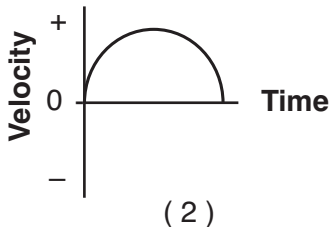
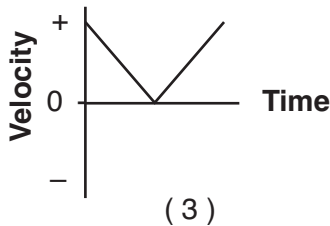
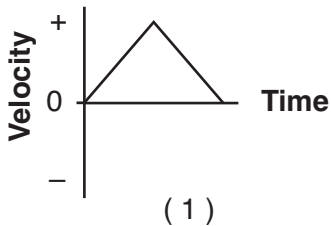

43 A 5.0-kilogram sphere, starting from rest, falls freely 22 meters in 3.0 seconds near the surface of a planet. Compared to the acceleration due to gravity near Earth's surface, the acceleration due to gravity near the surface of the planet is approximately

- (1) the same
 (2) twice as great
 (3) one-half as great
 (4) four times as great

44 A 15.0-kilogram mass is moving at 7.50 meters per second on a horizontal, frictionless surface. What is the total work that must be done on the mass to increase its speed to 11.5 meters per second?

- (1) 120. J
 (2) 422 J
 (3) 570. J
 (4) 992 J

45 The circuit diagram below represents four resistors connected to a 12-volt source.

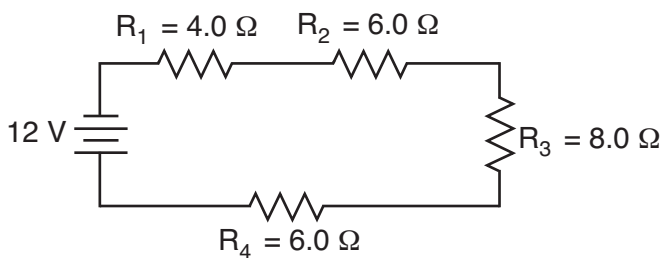

What is the total current in the circuit?

- (1) 0.50 A
 (2) 2.0 A
 (3) 8.6 A
 (4) 24 A

46 Which graph best represents the relationship between the power expended by a resistor that obeys Ohm's Law and the potential difference applied to the resistor?

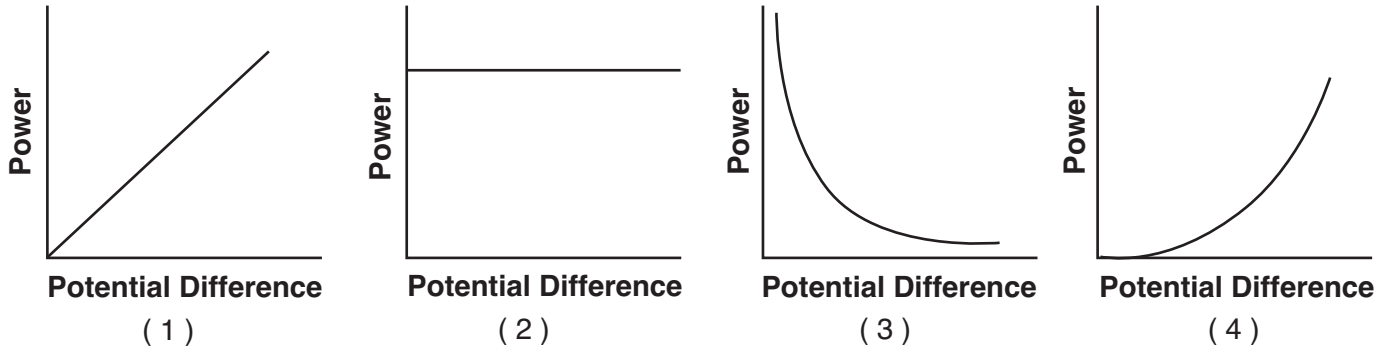

47 The distance between an electron and a proton is varied. Which pair of graphs best represents the relationship between gravitational force, F_g , and distance, r , and the relationship between electrostatic force, F_e , and distance, r , for these particles?

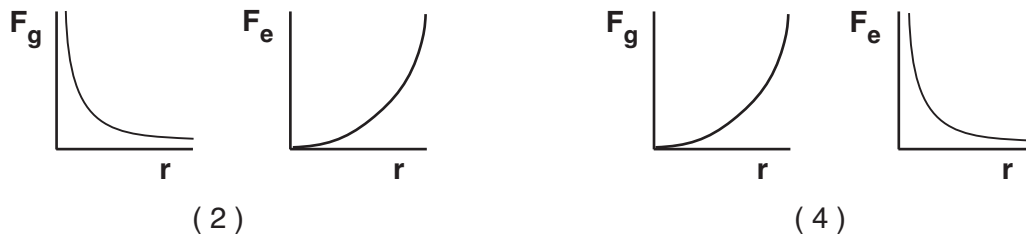
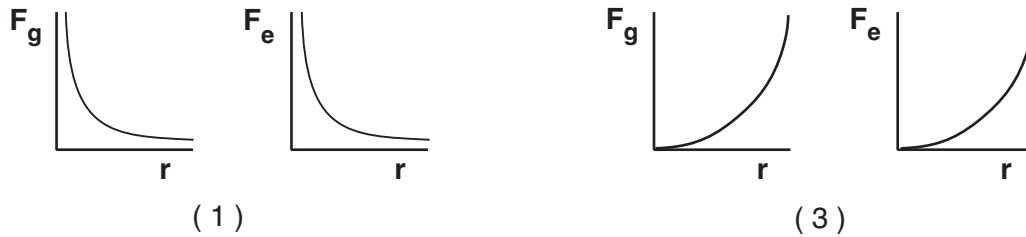

48 The diagram below represents a periodic wave traveling through a uniform medium.

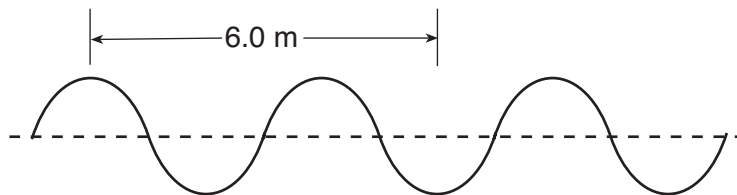

If the frequency of the wave is 2.0 hertz, the speed of the wave is

- (1) 6.0 m/s
- (2) 2.0 m/s
- (3) 8.0 m/s
- (4) 4.0 m/s

49 The diagram below represents a light ray reflecting from a plane mirror.

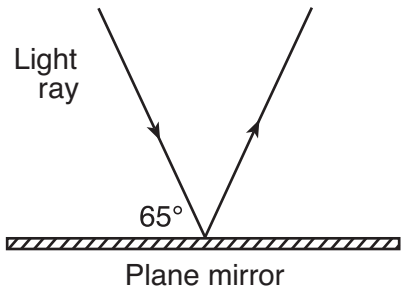

The angle of reflection for the light ray is

- (1) 25°
- (2) 35°
- (3) 50°
- (4) 65°

50 The diagram below shows a standing wave in a string clamped at each end.

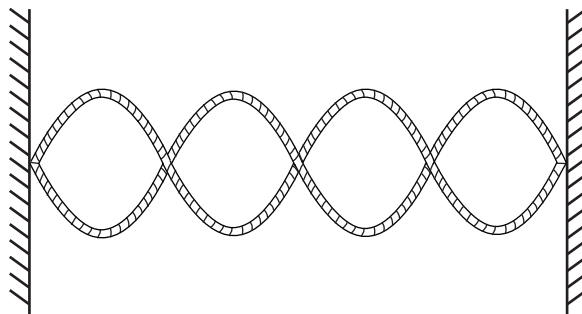

What is the total number of nodes and antinodes in the standing wave?

- (1) 3 nodes and 2 antinodes
 - (2) 2 nodes and 3 antinodes
 - (3) 5 nodes and 4 antinodes
 - (4) 4 nodes and 5 antinodes
-

Part B–2

Answer all questions in this part.

Directions (51–60): Record your answers in the spaces provided in your answer booklet.

Base your answers to questions 51 through 53 on the information and graph below.

A machine fired several projectiles at the same angle, θ , above the horizontal. Each projectile was fired with a different initial velocity, v_i . The graph below represents the relationship between the magnitude of the initial vertical velocity, v_{iy} , and the magnitude of the corresponding initial velocity, v_i , of these projectiles.

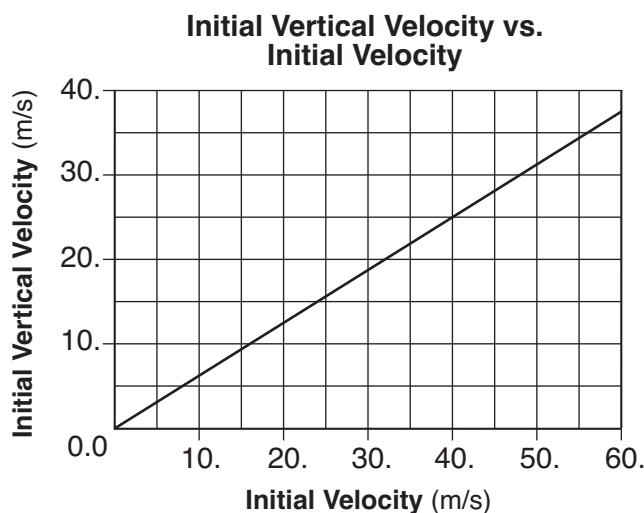

- 51 Determine the magnitude of the initial vertical velocity of the projectile, v_{iy} , when the magnitude of its initial velocity, v_i , was 40. meters per second. [1]
- 52 Determine the angle, θ , above the horizontal at which the projectiles were fired. [1]
- 53 Calculate the magnitude of the initial horizontal velocity of the projectile, v_{ix} , when the magnitude of its initial velocity, v_i , was 40. meters per second. [Show all work, including the equation and substitution with units.] [2]
-
- 54 A student makes a simple pendulum by attaching a mass to the free end of a 1.50-meter length of string suspended from the ceiling of her physics classroom. She pulls the mass up to her chin and releases it from rest, allowing the pendulum to swing in its curved path. Her classmates are surprised that the mass doesn't reach her chin on the return swing, even though she does not move. Explain why the mass does *not* have enough energy to return to its starting position and hit the girl on the chin. [1]

55 A 6-ohm resistor and a 4-ohm resistor are connected in series with a 6-volt battery in an operating electric circuit. A voltmeter is connected to measure the potential difference across the 6-ohm resistor.

In the space *in your answer booklet*, draw a diagram of this circuit including the battery, resistors, and voltmeter using symbols from the *Reference Tables for Physical Setting/Physics*. Label each resistor with its value. [Assume the availability of any number of wires of negligible resistance.] [2]

56 When a spring is compressed 2.50×10^{-2} meter from its equilibrium position, the total potential energy stored in the spring is 1.25×10^{-2} joule. Calculate the spring constant of the spring. [Show all work, including the equation and substitution with units.] [2]

Base your answers to questions 57 and 58 on the information below.

A 3.50-meter length of wire with a cross-sectional area of 3.14×10^{-6} meter² is at 20° Celsius. The current in the wire is 24.0 amperes when connected to a 1.50-volt source of potential difference.

57 Determine the resistance of the wire. [1]

58 Calculate the resistivity of the wire. [Show all work, including the equation and substitution with units.] [2]

Base your answers to questions 59 and 60 on the information below.

In an experiment, a 0.028-kilogram rubber stopper is attached to one end of a string. A student whirls the stopper overhead in a horizontal circle with a radius of 1.0 meter. The stopper completes 10. revolutions in 10. seconds.

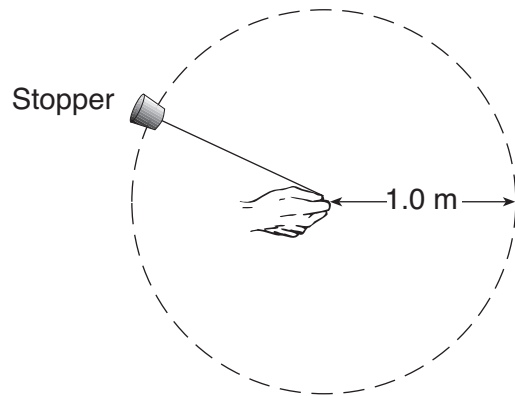

(Not drawn to scale)

59 Determine the speed of the whirling stopper. [1]

60 Calculate the magnitude of the centripetal force on the whirling stopper. [Show all work, including the equation and substitution with units.] [2]

Part C

Answer all questions in this part.

Directions (61–75): Record your answers in the spaces provided in your answer booklet.

Base your answers to questions 61 through 64 on the information below.

In a laboratory investigation, a student applied various downward forces to a vertical spring. The applied forces and the corresponding elongations of the spring from its equilibrium position are recorded in the data table below.

Data Table

Force (N)	Elongation (m)
0	0
0.5	0.010
1.0	0.018
1.5	0.027
2.0	0.035
2.5	0.046

Directions (61–63): Construct a graph on the grid *in your answer booklet*, following the directions below.

- 61 Mark an appropriate scale on the axis labeled “Force (N).” [1]
- 62 Plot the data points for force versus elongation. [1]
- 63 Draw the best-fit line or curve. [1]
- 64 Using your graph, calculate the spring constant of this spring. [Show all work, including the equation and substitution with units.] [2]
-

Base your answers to questions 65 through 68 on the information below.

An ice skater applies a horizontal force to a 20.-kilogram block on frictionless, level ice, causing the block to accelerate uniformly at 1.4 meters per second² to the right. After the skater stops pushing the block, it slides onto a region of ice that is covered with a thin layer of sand. The coefficient of kinetic friction between the block and the sand-covered ice is 0.28.

- 65 Calculate the magnitude of the force applied to the block by the skater. [Show all work, including the equation and substitution with units.] [2]
- 66 On the diagram *in your answer booklet*, starting at point A, draw a vector to represent the force applied to the block by the skater. Begin the vector at point A and use a scale of 1.0 centimeter = 5.0 newtons. [1]
- 67 Determine the magnitude of the normal force acting on the block. [1]
- 68 Calculate the magnitude of the force of friction acting on the block as it slides over the sand-covered ice. [Show all work, including the equation and substitution with units.] [2]

Base your answers to questions 69 through 71 on the information and diagram below.

A monochromatic light ray ($f = 5.09 \times 10^{14}$ Hz) traveling in air is incident on the surface of a rectangular block of Lucite.

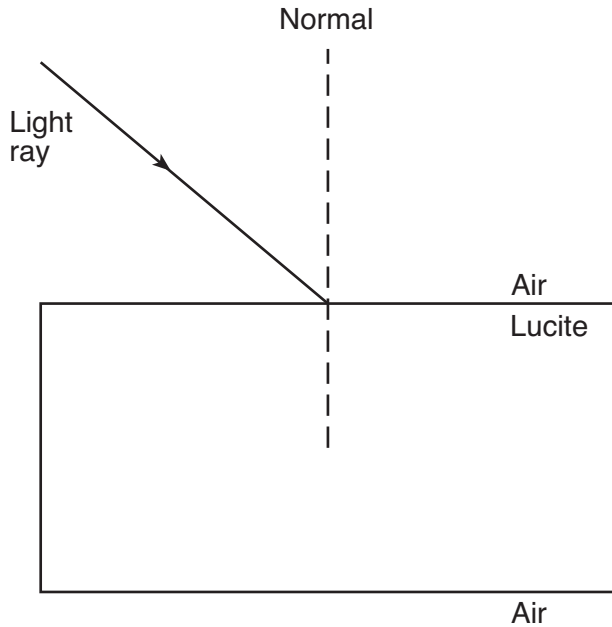

69 Measure the angle of incidence for the light ray to the *nearest degree*. [1]

70 Calculate the angle of refraction of the light ray when it enters the Lucite block. [Show all work, including the equation and substitution with units.] [2]

71 What is the angle of refraction of the light ray as it emerges from the Lucite block back into air? [1]

Base your answers to questions 72 through 75 on the information below.

As a mercury atom absorbs a photon of energy, an electron in the atom changes from energy level d to energy level e .

72 Determine the energy of the absorbed photon in electronvolts. [1]

73 Express the energy of the absorbed photon in joules. [1]

74 Calculate the frequency of the absorbed photon. [Show all work, including the equation and substitution with units.] [2]

75 Based on your calculated value of the frequency of the absorbed photon, determine its classification in the electromagnetic spectrum. [1]
