

GEOMETRY

Friday, June 21, 2019 — 9:15 a.m. to 12:15 p.m., only

Student Name: _____

School Name: _____

The possession or use of any communications device is strictly prohibited when taking this examination. If you have or use any communications device, no matter how briefly, your examination will be invalidated and no score will be calculated for you.

Print your name and the name of your school on the lines above.

A separate answer sheet for **Part I** has been provided to you. Follow the instructions from the proctor for completing the student information on your answer sheet.

This examination has four parts, with a total of 35 questions. You must answer all questions in this examination. Record your answers to the Part I multiple-choice questions on the separate answer sheet. Write your answers to the questions in **Parts II, III, and IV** directly in this booklet. All work should be written in pen, except for graphs and drawings, which should be done in pencil. Clearly indicate the necessary steps, including appropriate formula substitutions, diagrams, graphs, charts, etc. Utilize the information provided for each question to determine your answer. Note that diagrams are not necessarily drawn to scale.

The formulas that you may need to answer some questions in this examination are found at the end of the examination. This sheet is perforated so you may remove it from this booklet.

Scrap paper is not permitted for any part of this examination, but you may use the blank spaces in this booklet as scrap paper. A perforated sheet of scrap graph paper is provided at the end of this booklet for any question for which graphing may be helpful but is not required. You may remove this sheet from this booklet. Any work done on this sheet of scrap graph paper will *not* be scored.

When you have completed the examination, you must sign the statement printed at the end of the answer sheet, indicating that you had no unlawful knowledge of the questions or answers prior to the examination and that you have neither given nor received assistance in answering any of the questions during the examination. Your answer sheet cannot be accepted if you fail to sign this declaration.

Notice...

A graphing calculator, a straightedge (ruler), and a compass must be available for you to use while taking this examination.

DO NOT OPEN THIS EXAMINATION BOOKLET UNTIL THE SIGNAL IS GIVEN.

Part I

Answer all 24 questions in this part. Each correct answer will receive 2 credits. No partial credit will be allowed. Utilize the information provided for each question to determine your answer. Note that diagrams are not necessarily drawn to scale. For each statement or question, choose the word or expression that, of those given, best completes the statement or answers the question. Record your answers on your separate answer sheet. [48]

Use this space for computations.

- 1 On the set of axes below, triangle ABC is graphed. Triangles $A'B'C'$ and $A''B''C''$, the images of triangle ABC , are graphed after a sequence of rigid motions.

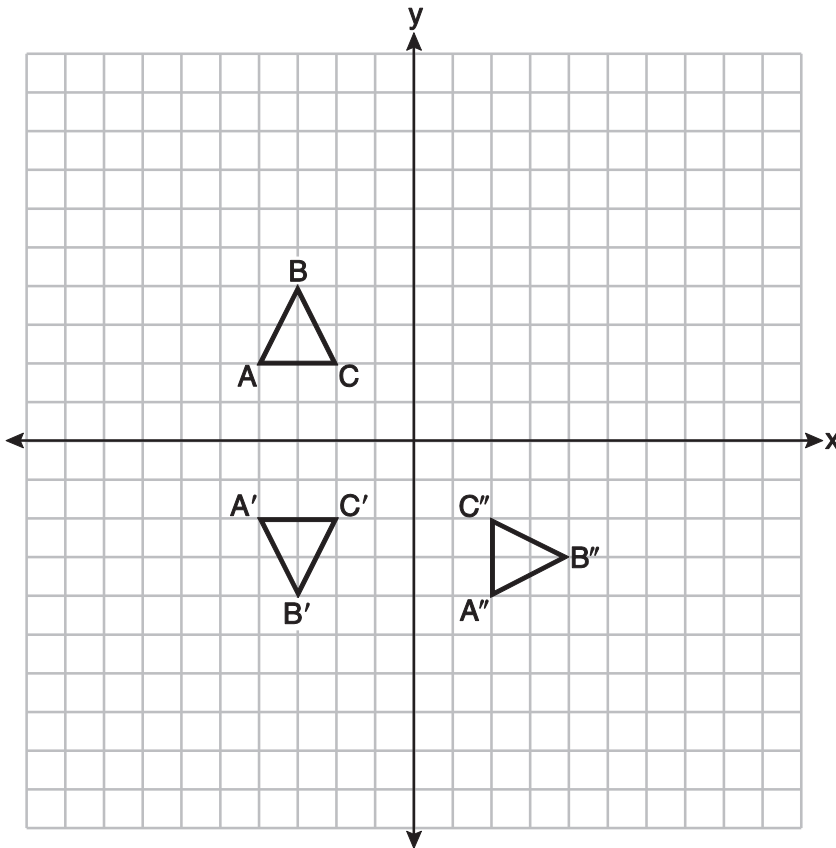

Identify which sequence of rigid motions maps $\triangle ABC$ onto $\triangle A'B'C'$ and then maps $\triangle A'B'C'$ onto $\triangle A''B''C''$.

- (1) a rotation followed by another rotation
- (2) a translation followed by a reflection
- (3) a reflection followed by a translation
- (4) a reflection followed by a rotation

**Use this space for
computations.**

- 2** The table below shows the population and land area, in square miles, of four counties in New York State at the turn of the century.

County	2000 Census Population	2000 Land Area (mi²)
Broome	200,536	706.82
Dutchess	280,150	801.59
Niagara	219,846	522.95
Saratoga	200,635	811.84

Which county had the greatest population density?

- (1) Broome (3) Niagara
(2) Dutchess (4) Saratoga
- 3** If a rectangle is continuously rotated around one of its sides, what is the three-dimensional figure formed?
- (1) rectangular prism (3) sphere
(2) cylinder (4) cone

**Use this space for
computations.**

4 Which transformation carries the parallelogram below onto itself?

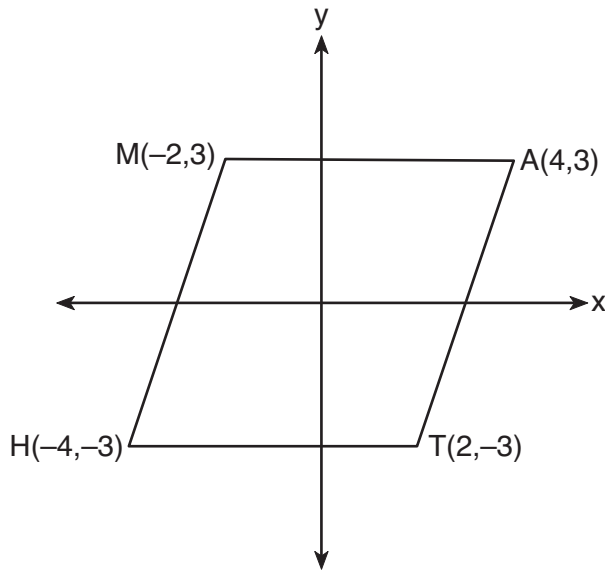

- (1) a reflection over $y = x$
- (2) a reflection over $y = -x$
- (3) a rotation of 90° counterclockwise about the origin
- (4) a rotation of 180° counterclockwise about the origin

5 After a dilation centered at the origin, the image of \overline{CD} is $\overline{C'D'}$. If the coordinates of the endpoints of these segments are $C(6,-4)$, $D(2,-8)$, $C'(9,-6)$, and $D'(3,-12)$, the scale factor of the dilation is

- (1) $\frac{3}{2}$
- (2) $\frac{2}{3}$
- (3) 3
- (4) $\frac{1}{3}$

Use this space for computations.

10 What is the volume of a hemisphere that has a diameter of 12.6 cm, to the *nearest tenth of a cubic centimeter*?

- (1) 523.7 (3) 4189.6
(2) 1047.4 (4) 8379.2

11 In the diagram below of $\triangle ABC$, D is a point on \overline{BA} , E is a point on \overline{BC} , and \overline{DE} is drawn.

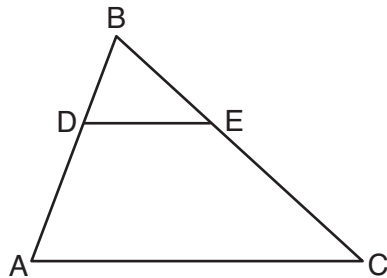

If $BD = 5$, $DA = 12$, and $BE = 7$, what is the length of \overline{BC} so that $\overline{AC} \parallel \overline{DE}$?

- (1) 23.8 (3) 15.6
(2) 16.8 (4) 8.6

12 A quadrilateral must be a parallelogram if

- (1) one pair of sides is parallel and one pair of angles is congruent
(2) one pair of sides is congruent and one pair of angles is congruent
(3) one pair of sides is both parallel and congruent
(4) the diagonals are congruent

Use this space for computations.

13 In the diagram below of circle O , chords \overline{JT} and \overline{ER} intersect at M .

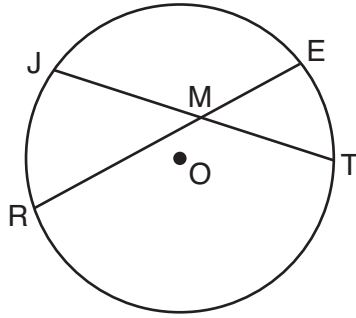

If $EM = 8$ and $RM = 15$, the lengths of \overline{JM} and \overline{TM} could be

- (1) 12 and 9.5
- (2) 14 and 8.5
- (3) 16 and 7.5
- (4) 18 and 6.5

14 Triangles JOE and SAM are drawn such that $\angle E \cong \angle M$ and $\overline{EJ} \cong \overline{MS}$. Which mapping would *not* always lead to $\triangle JOE \cong \triangle SAM$?

- (1) $\angle J$ maps onto $\angle S$
- (2) $\angle O$ maps onto $\angle A$
- (3) \overline{EO} maps onto \overline{MA}
- (4) \overline{JO} maps onto \overline{SA}

15 In $\triangle ABC$ shown below, $\angle ACB$ is a right angle, E is a point on \overline{AC} , and \overline{ED} is drawn perpendicular to hypotenuse \overline{AB} .

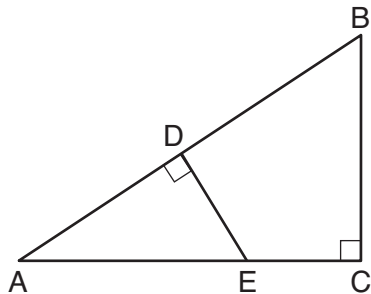

If $AB = 9$, $BC = 6$, and $DE = 4$, what is the length of \overline{AE} ?

- (1) 5
- (2) 6
- (3) 7
- (4) 8

Use this space for
computations.

16 Which equation represents a line parallel to the line whose equation is $-2x + 3y = -4$ and passes through the point $(1,3)$?

(1) $y - 3 = -\frac{3}{2}(x - 1)$ (3) $y + 3 = -\frac{3}{2}(x + 1)$

(2) $y - 3 = \frac{2}{3}(x - 1)$ (4) $y + 3 = \frac{2}{3}(x + 1)$

17 In rhombus $TIGE$, diagonals \overline{TG} and \overline{IE} intersect at R . The perimeter of $TIGE$ is 68, and $TG = 16$.

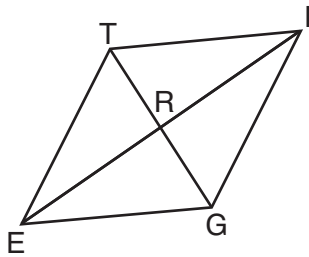

What is the length of diagonal \overline{IE} ?

- (1) 15 (3) 34
(2) 30 (4) 52

18 In circle O two secants, \overline{ABP} and \overline{CDP} , are drawn to external point P . If $m\widehat{AC} = 72^\circ$, and $m\widehat{BD} = 34^\circ$, what is the measure of $\angle P$?

- (1) 19° (3) 53°
(2) 38° (4) 106°

Part II

Answer all 7 questions in this part. Each correct answer will receive 2 credits. Clearly indicate the necessary steps, including appropriate formula substitutions, diagrams, graphs, charts, etc. Utilize the information provided for each question to determine your answer. Note that diagrams are not necessarily drawn to scale. For all questions in this part, a correct numerical answer with no work shown will receive only 1 credit. All answers should be written in pen, except for graphs and drawings, which should be done in pencil. [14]

25 Triangle $A'B'C'$ is the image of triangle ABC after a dilation with a scale factor of $\frac{1}{2}$ and centered at point A . Is triangle ABC congruent to triangle $A'B'C'$? Explain your answer.

26 Determine and state the area of triangle PQR , whose vertices have coordinates $P(-2, -5)$, $Q(3, 5)$, and $R(6, 1)$.

[The use of the set of axes below is optional.]

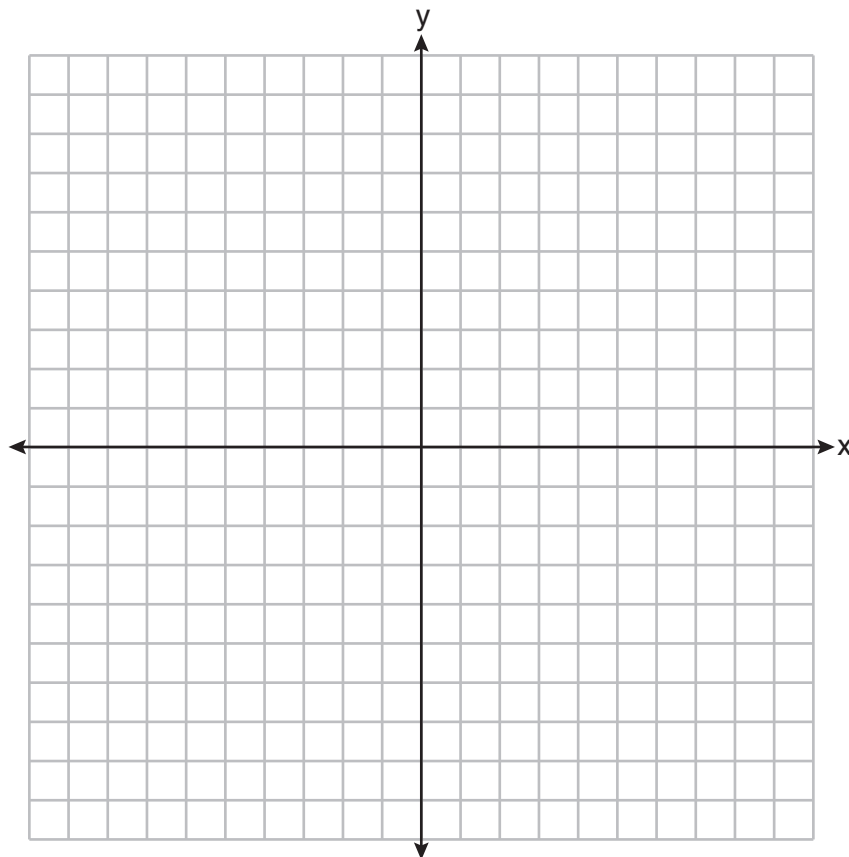

27 A support wire reaches from the top of a pole to a clamp on the ground. The pole is perpendicular to the level ground and the clamp is 10 feet from the base of the pole. The support wire makes a 68° angle with the ground. Find the length of the support wire to the *nearest foot*.

28 In the diagram below, circle O has a radius of 10.

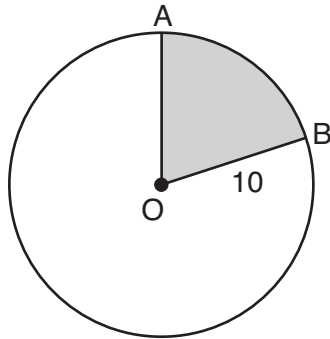

If $m\widehat{AB} = 72^\circ$, find the area of shaded sector AOB , in terms of π .

29 On the set of axes below, $\triangle ABC \cong \triangle STU$.

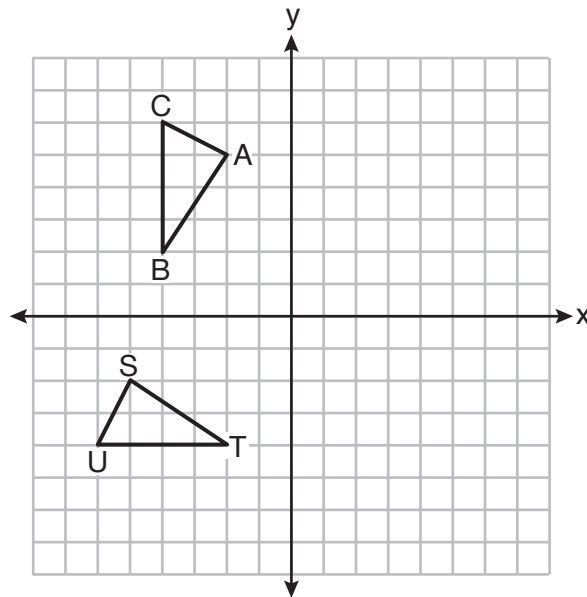

Describe a sequence of rigid motions that maps $\triangle ABC$ onto $\triangle STU$.

30 In right triangle PRT , $m\angle P = 90^\circ$, altitude \overline{PQ} is drawn to hypotenuse \overline{RT} , $RT = 17$, and $PR = 15$.

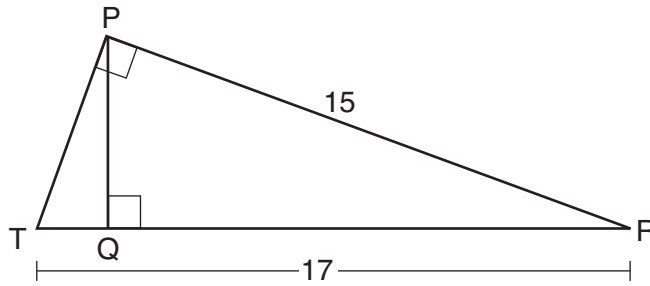

Determine and state, to the *nearest tenth*, the length of \overline{RQ} .

31 Given circle O with radius \overline{OA} , use a compass and straightedge to construct an equilateral triangle inscribed in circle O . [Leave all construction marks.]

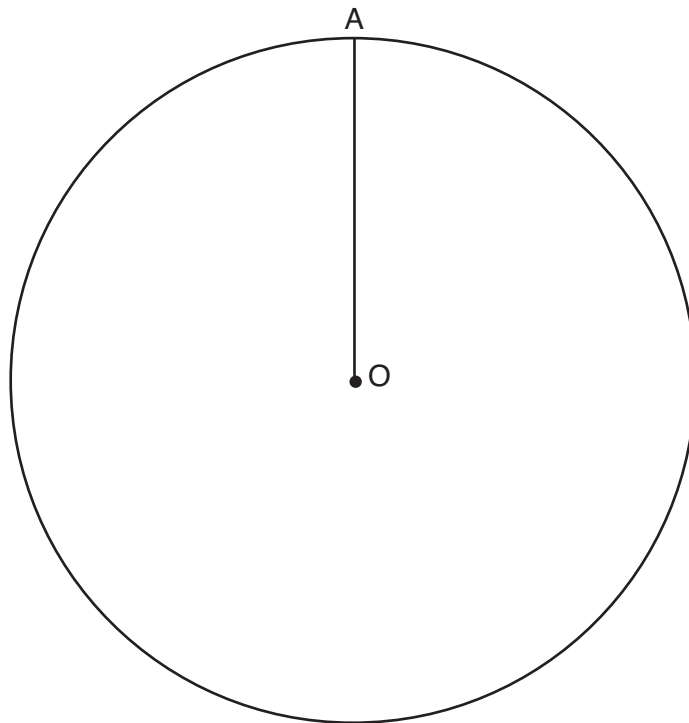

Part III

Answer all 3 questions in this part. Each correct answer will receive 4 credits. Clearly indicate the necessary steps, including appropriate formula substitutions, diagrams, graphs, charts, etc. Utilize the information provided for each question to determine your answer. Note that diagrams are not necessarily drawn to scale. For all questions in this part, a correct numerical answer with no work shown will receive only 1 credit. All answers should be written in pen, except for graphs and drawings, which should be done in pencil. [12]

32 Riley plotted $A(-1,6)$, $B(3,8)$, $C(6,-1)$, and $D(1,0)$ to form a quadrilateral.

Prove that Riley's quadrilateral $ABCD$ is a trapezoid.

[The use of the set of axes on the next page is optional.]

Question 32 is continued on the next page.

Question 32 continued

Riley defines an isosceles trapezoid as a trapezoid with congruent diagonals. Use Riley's definition to prove that $ABCD$ is *not* an isosceles trapezoid.

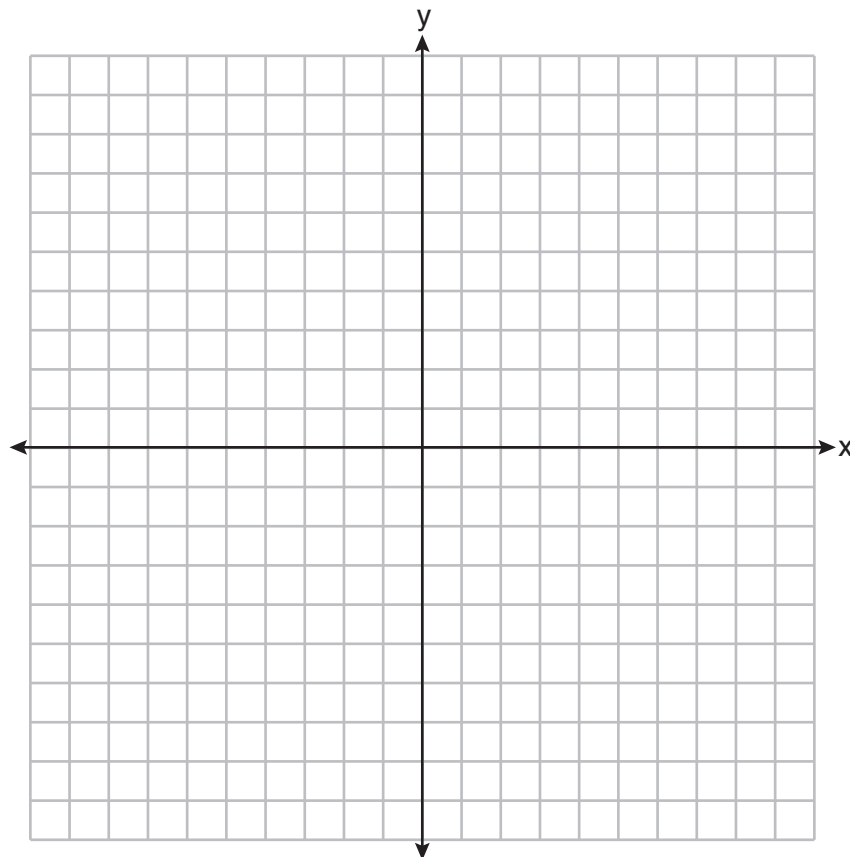

33 A child-sized swimming pool can be modeled by a cylinder. The pool has a diameter of $6\frac{1}{2}$ feet and a height of 12 inches. The pool is filled with water to $\frac{2}{3}$ of its height. Determine and state the volume of the water in the pool, to the *nearest cubic foot*.

One cubic foot equals 7.48 gallons of water. Determine and state, to the *nearest gallon*, the number of gallons of water in the pool.

34 Nick wanted to determine the length of one blade of the windmill pictured below. He stood at a point on the ground 440 feet from the windmill's base. Using surveyor's tools, Nick measured the angle between the ground and the highest point reached by the top blade and found it was 38.8° . He also measured the angle between the ground and the lowest point of the top blade, and found it was 30° .

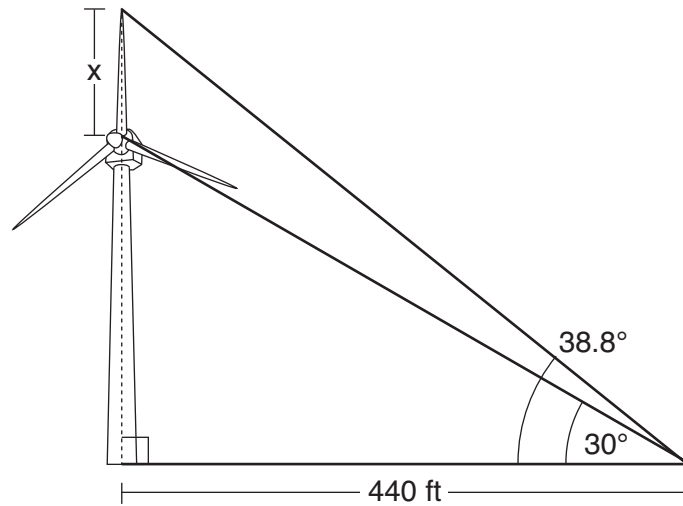

Determine and state a blade's length, x , to the *nearest foot*.

Part IV

Answer the question in this part. A correct answer will receive 6 credits. Clearly indicate the necessary steps, including appropriate formula substitutions, diagrams, graphs, charts, etc. Utilize the information provided for the question to determine your answer. Note that diagrams are not necessarily drawn to scale. For the question in this part, a correct numerical answer with no work shown will receive only 1 credit. All answers should be written in pen, except for graphs and drawings, which should be done in pencil. [6]

35 Given: Quadrilateral $MATH$, $\overline{HM} \cong \overline{AT}$, $\overline{HT} \cong \overline{AM}$, $\overline{HE} \perp \overline{MEA}$, and $\overline{HA} \perp \overline{AT}$

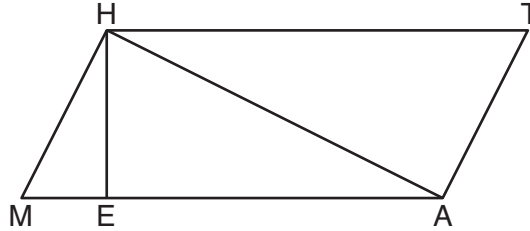

Prove: $TA \cdot HA = HE \cdot TH$

Work space for question 35 is continued on the next page.

Question 35 continued

Scrap Graph Paper — This sheet will *not* be scored.

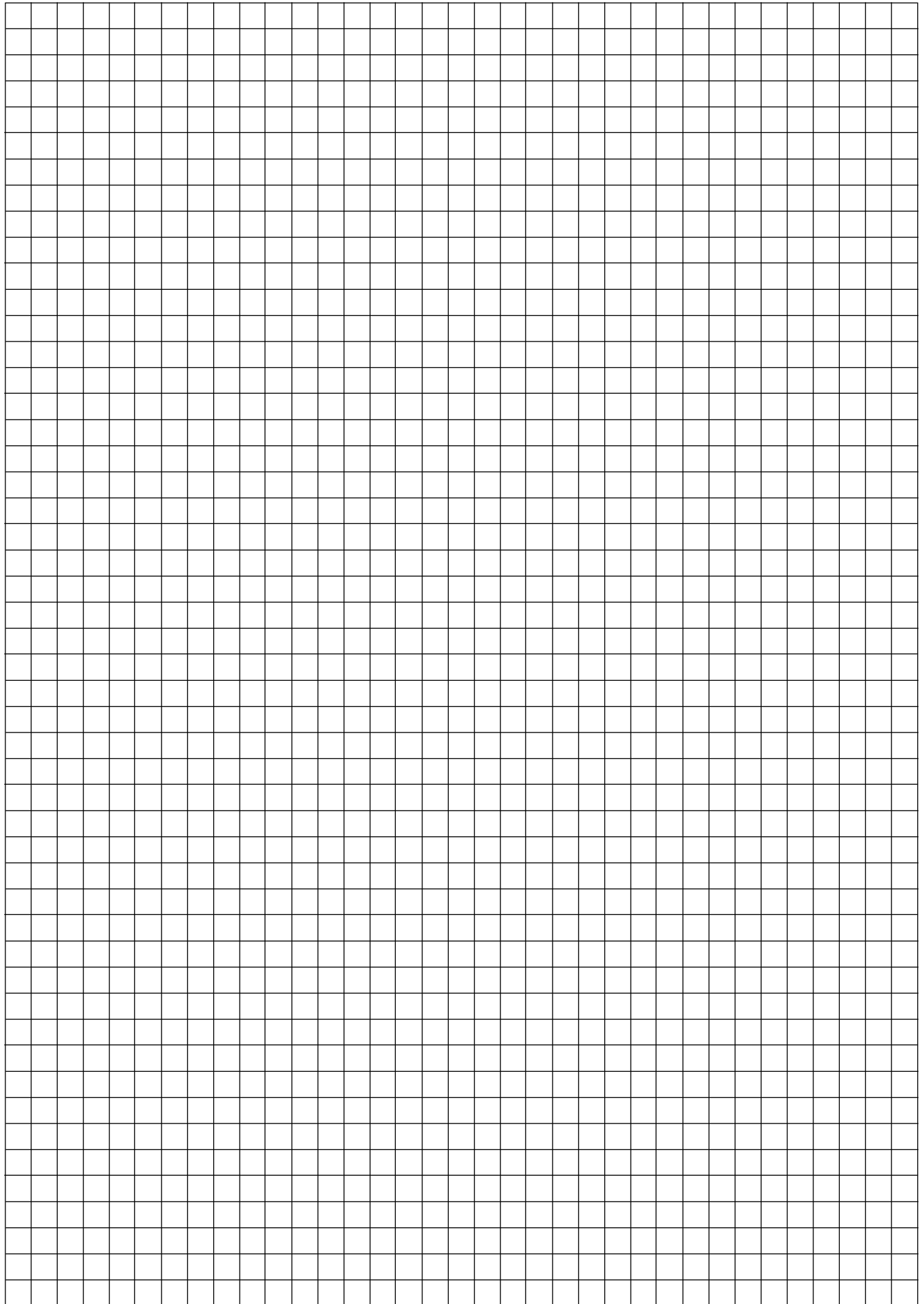

Tear Here

Tear Here

Scrap Graph Paper — This sheet will *not* be scored.

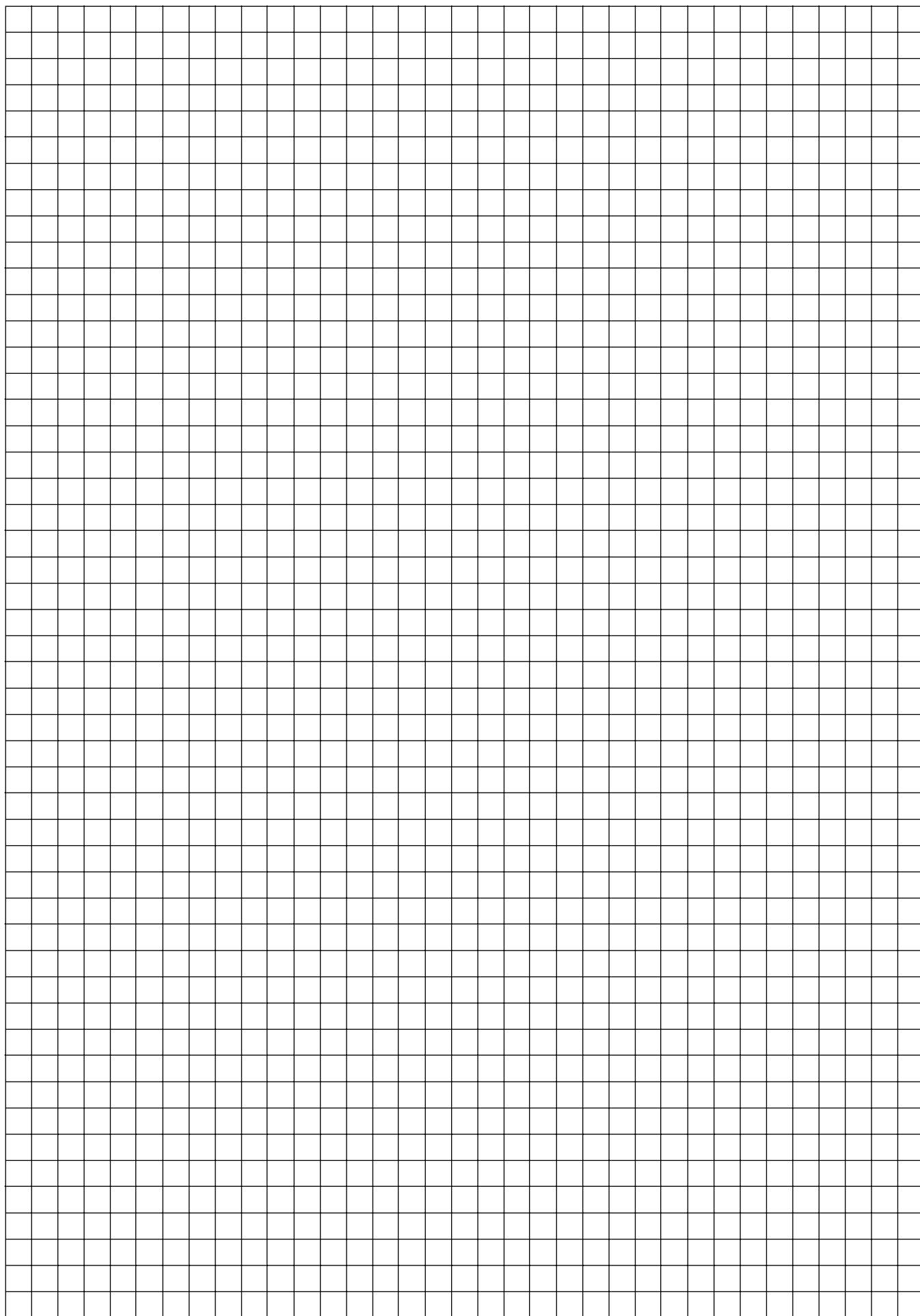

Tear Here

Tear Here

High School Math Reference Sheet

1 inch = 2.54 centimeters	1 kilometer = 0.62 mile	1 cup = 8 fluid ounces
1 meter = 39.37 inches	1 pound = 16 ounces	1 pint = 2 cups
1 mile = 5280 feet	1 pound = 0.454 kilogram	1 quart = 2 pints
1 mile = 1760 yards	1 kilogram = 2.2 pounds	1 gallon = 4 quarts
1 mile = 1.609 kilometers	1 ton = 2000 pounds	1 gallon = 3.785 liters
		1 liter = 0.264 gallon
		1 liter = 1000 cubic centimeters

Triangle	$A = \frac{1}{2}bh$
Parallelogram	$A = bh$
Circle	$A = \pi r^2$
Circle	$C = \pi d$ or $C = 2\pi r$
General Prisms	$V = Bh$
Cylinder	$V = \pi r^2 h$
Sphere	$V = \frac{4}{3}\pi r^3$
Cone	$V = \frac{1}{3}\pi r^2 h$
Pyramid	$V = \frac{1}{3}Bh$

Pythagorean Theorem	$a^2 + b^2 = c^2$
Quadratic Formula	$x = \frac{-b \pm \sqrt{b^2 - 4ac}}{2a}$
Arithmetic Sequence	$a_n = a_1 + (n - 1)d$
Geometric Sequence	$a_n = a_1 r^{n-1}$
Geometric Series	$S_n = \frac{a_1 - a_1 r^n}{1 - r}$ where $r \neq 1$
Radians	1 radian = $\frac{180}{\pi}$ degrees
Degrees	1 degree = $\frac{\pi}{180}$ radians
Exponential Growth/Decay	$A = A_0 e^{k(t - t_0)} + B_0$

Tear Here

Tear Here

GEOMETRY

Tear Here

Tear Here

Printed on Recycled Paper

GEOMETRY