

Large-Type Edition

The University of the State of New York
REGENTS HIGH SCHOOL EXAMINATION

PHYSICAL SETTING CHEMISTRY

Friday, January 27, 2023 — 9:15 a.m. to 12:15 p.m., only

The possession or use of any communications device is strictly prohibited when taking this examination. If you have or use any communications device, no matter how briefly, your examination will be invalidated and no score will be calculated for you.

This is a test of your knowledge of chemistry. Use that knowledge to answer all questions in this examination. Some questions may require the use of the *2011 Edition Reference Tables for Physical Setting/Chemistry*. You are to answer *all* questions in all parts of this examination according to the directions provided in this examination booklet.

A separate answer sheet for Part A and Part B-1 has been provided to you. Follow the instructions from the proctor for completing the student information on your answer sheet. Record your answers to the Part A and Part B-1 multiple-choice questions on this separate answer sheet. Record your answers for the questions in Part B-2 and Part C in your separate answer booklet. Be sure to fill in the heading on the front of your answer booklet.

All answers in your answer booklet should be written in pen, except for graphs and drawings, which should be done in pencil. You may use scrap paper to work out the answers to the questions, but be sure to record all your answers on your separate answer sheet or in your answer booklet as directed.

When you have completed the examination, you must sign the statement printed on your separate answer sheet, indicating that you had no unlawful knowledge of the questions or answers prior to the examination and that you have neither given nor received assistance in answering any of the questions during the examination. Your answer sheet and answer booklet cannot be accepted if you fail to sign this declaration.

Notice...

A four-function or scientific calculator and a copy of the *2011 Edition Reference Tables for Physical Setting/Chemistry* must be available for you to use while taking this examination.

DO NOT START THIS EXAMINATION UNTIL THE SIGNAL IS GIVEN.

Part A

Answer all questions in this part.

Directions (1–30): For *each* statement or question, record on your separate answer sheet the *number* of the word or expression that, of those given, best completes the statement or answers the question. Some questions may require the use of the *2011 Edition Reference Tables for Physical Setting/Chemistry*.

- 1 Which conclusion was developed as a result of the gold foil experiment?
 - (1) Atoms are mostly empty space.
 - (2) All atoms are hard, indivisible spheres.
 - (3) Atoms have different volumes.
 - (4) All atoms have the same volume.
 - 2 Which two particles each have a mass approximately equal to one atomic mass unit?
 - (1) positron and proton
 - (2) positron and electron
 - (3) neutron and electron
 - (4) neutron and proton
 - 3 An excited potassium atom emits a specific amount of energy when one of its electrons moves from
 - (1) the first shell to the fourth shell
 - (2) the second shell to the fourth shell
 - (3) the fourth shell to the fifth shell
 - (4) the fourth shell to the second shell
 - 4 Which list of elements includes a metal, a metalloid, and a noble gas?
 - (1) Rb, Cl, Ne
 - (2) Sr, Si, Rn
 - (3) Rn, Cl, Ne
 - (4) Si, Rb, Sr
 - 5 Which element has the *lowest* density at 298 K and 101.3 kPa?
 - (1) argon
 - (2) fluorine
 - (3) nitrogen
 - (4) oxygen
-

6 Which phrase describes the crystal structure and properties of two different forms of solid carbon called diamond and graphite?

- (1) same crystal structure and same properties
- (2) same crystal structure and different properties
- (3) different crystal structures and different properties
- (4) different crystal structures and same properties

7 Which element has chemical properties most similar to sodium?

- (1) magnesium
- (2) oxygen
- (3) phosphorus
- (4) rubidium

8 Which substance contains elements chemically combined in a fixed proportion?

- (1) manganese
- (2) methane
- (3) silicon
- (4) strontium

9 Which property can be used to differentiate between a 50.-gram sample of solid potassium nitrate at STP and a 50.-gram sample of solid silver chloride at STP?

- (1) mass
- (2) temperature
- (3) phase
- (4) solubility

10 Which type of bond forms when electrons are equally shared between two atoms?

- (1) a polar covalent bond
- (2) a nonpolar covalent bond
- (3) a hydrogen bond
- (4) an ionic bond

11 Which statement describes the changes in bonding and energy that occur when a molecule of iodine, I_2 , forms two separate atoms of iodine?

- (1) A bond is formed as energy is absorbed.
- (2) A bond is formed as energy is released.
- (3) A bond is broken as energy is absorbed.
- (4) A bond is broken as energy is released.

- 12 The degree of polarity in the bond between a hydrogen atom and an oxygen atom in a molecule of water can be assessed using the difference in
- (1) densities
 - (2) electronegativities
 - (3) melting points
 - (4) intermolecular forces

- 13 Which substance can *not* be broken down by a chemical change?

- (1) ammonia
- (2) ethanol
- (3) krypton
- (4) water

- 14 Which sample of matter is a mixture?

- (1) $\text{CO}_2(\text{g})$
- (2) $\text{CCl}_4(\ell)$
- (3) $\text{MgCl}_2(\text{aq})$
- (4) $\text{Sn}(\text{s})$

- 15 Which term is used to express the concentration of an aqueous solution?

- (1) parts per million
- (2) heat of fusion
- (3) pressure at 0°C
- (4) volume at 0°C

- 16 The particles in which sample have the *lowest* average kinetic energy?

- (1) 50. g of sulfur at 273 K
- (2) 40. g of aluminum at 298 K
- (3) 30. g of sulfur at 303 K
- (4) 20. g of aluminum at 323 K

- 17 Which process represents a chemical change?

- (1) Iodine sublimes.
- (2) Water evaporates.
- (3) An ice cube melts.
- (4) A candle burns in air.

- 18 Which equation represents a physical equilibrium?

- (1) $\text{NaCl}(\text{s}) \xrightarrow{\text{H}_2\text{O}} \text{Na}^+(\text{aq}) + \text{Cl}^-(\text{aq})$
- (2) $2\text{SO}_2(\text{g}) + \text{O}_2(\text{g}) \rightleftharpoons 2\text{SO}_3(\text{g})$
- (3) $3\text{O}_2(\text{g}) \rightarrow 2\text{O}_3(\text{g})$
- (4) $\text{N}_2(\ell) \rightleftharpoons \text{N}_2(\text{g})$

- 19 Systems in nature tend to undergo changes toward

- (1) higher energy and higher entropy
- (2) higher energy and lower entropy
- (3) lower energy and higher entropy
- (4) lower energy and lower entropy

- 20 Which formula represents a hydrocarbon?
(1) C_2H_6 (3) C_2H_5Cl
(2) C_2H_5OH (4) C_2H_6O
- 21 Which statement describes the bonding in an alkyne molecule?
(1) There is at least one carbon-to-carbon double bond.
(2) There is at least one carbon-to-carbon triple bond.
(3) There is at least one carbon-to-oxygen single bond.
(4) There is at least one carbon-to-oxygen double bond.
- 22 Which compound has a functional group that contains two oxygen atoms?
(1) 1-propanamine (3) methyl propanoate
(2) 2-chloropropane (4) methyl ethyl ether
- 23 Which term identifies a type of organic reaction?
(1) deposition (3) polymerization
(2) distillation (4) vaporization

- 24 In an electrochemical cell, oxidation occurs at the
(1) anode (3) salt bridge
(2) cathode (4) switch
- 25 Which energy conversion occurs in an operating electrolytic cell?
(1) chemical energy to electrical energy
(2) electrical energy to chemical energy
(3) nuclear energy to electrical energy
(4) electrical energy to nuclear energy
- 26 One acid-base theory states that a base is an
(1) H^- donor (3) H^+ donor
(2) H^- acceptor (4) H^+ acceptor

- 27 The acidity or alkalinity of a solution can be measured by its
(1) pH value
(2) electronegativity value
(3) boiling point
(4) freezing point

28 When the nucleus of an atom of neon-19 decays, which particle is emitted?

- (1) ${}^4_2\text{He}$
- (2) ${}^0_{-1}\text{e}$
- (3) ${}^1_0\text{n}$
- (4) ${}^0_{+1}\text{e}$

29 Which nuclear emission has the greatest mass?

- (1) positron
 - (2) gamma ray
 - (3) beta particle
 - (4) alpha particle
-

30 Which statement describes the net change that occurs during nuclear fission?

- (1) Electrons are converted to protons.
- (2) Protons are converted to electrons.
- (3) Mass is converted to energy.
- (4) Energy is converted to mass.

33 Which general trend is observed as the elements in Period 2 are considered from left to right?

- (1) Atomic mass decreases.
- (2) Melting point increases.
- (3) Electronegativity increases.
- (4) First ionization energy decreases.

34 Which formula represents chromium(III) oxide?

- (1) CrO_3
- (2) Cr_3O
- (3) Cr_2O_3
- (4) Cr_3O_2

35 Given the balanced equation representing a reaction:



What is the mass of KCl produced when 24.51 grams of KClO_3 reacts completely to produce 9.60 grams of O_2 ?

- (1) 5.31 g
- (2) 14.91 g
- (3) 34.11 g
- (4) 43.71 g

36 Which equation represents conservation of atoms?

- (1) $\text{TiO}_2 + 2\text{Al} \rightarrow 2\text{Al}_2\text{O}_3 + \text{Ti}$
- (2) $\text{TiO}_2 + 4\text{Al} \rightarrow 2\text{Al}_2\text{O}_3 + \text{Ti}$
- (3) $3\text{TiO}_2 + 2\text{Al} \rightarrow 2\text{Al}_2\text{O}_3 + 3\text{Ti}$
- (4) $3\text{TiO}_2 + 4\text{Al} \rightarrow 2\text{Al}_2\text{O}_3 + 3\text{Ti}$

37 One mole of bromine gas, Br_2 , has a mass of

- (1) 35.0 g
- (2) 70.0 g
- (3) 79.9 g
- (4) 159.8 g

38 Given the equation representing a reaction:



Which type of reaction does this equation represent?

- (1) double replacement
- (2) decomposition
- (3) synthesis
- (4) single replacement

39 Which statement describes the charge and the radius of the magnesium ion formed when a magnesium atom loses two electrons?

- (1) The Mg ion is positive and has a radius larger than the Mg atom.
- (2) The Mg ion is negative and has a radius larger than the Mg atom.
- (3) The Mg ion is positive and has a radius smaller than the Mg atom.
- (4) The Mg ion is negative and has a radius smaller than the Mg atom.

40 An oxide ion, O^{2-} , has the same electron configuration as an atom of which noble gas?

- (1) helium
- (2) neon
- (3) argon
- (4) krypton

41 What is the vapor pressure of propanone at $45^{\circ}C$?

- (1) 21 kPa
- (2) 60. kPa
- (3) 70. kPa
- (4) 79 kPa

42 Based on Table G, what is the mass of KCl that must be dissolved in 200. grams of H_2O at $10.^{\circ}C$ to make a saturated solution?

- (1) 15 g
- (2) 30. g
- (3) 60. g
- (4) 120. g

43 Based on Table I, which chemical equation represents a reaction with a heat of reaction that indicates a net release of energy?

- (1) $N_2(g) + O_2(g) \rightarrow 2NO(g)$
- (2) $N_2(g) + 2O_2(g) \rightarrow 2NO_2(g)$
- (3) $2C(s) + 3H_2(g) \rightarrow C_2H_6(g)$
- (4) $2C(s) + 2H_2(g) \rightarrow C_2H_4(g)$

44 The greatest increase in entropy occurs when a 1.00-gram sample of water changes from

- (1) solid to liquid
- (2) solid to gas
- (3) gas to liquid
- (4) liquid to solid

45 Which particle diagram represents one substance, only?

Key
○ = atom of one element
● = atom of a different element

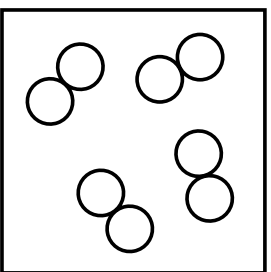

(1)

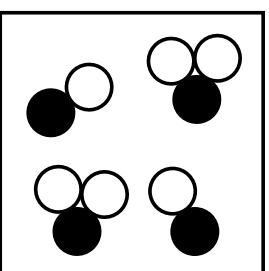

(3)

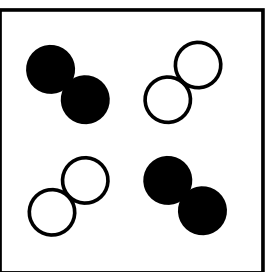

(2)

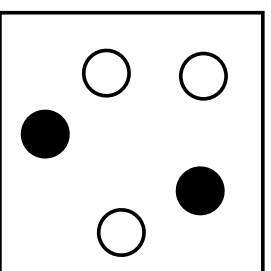

(4)

46 Based on Table J, atoms of which metal will lose electrons to Ca^{2+} ions?

- (1) aluminum (3) nickel
 (2) lead (4) potassium

47 Which aqueous solution is the best conductor of an electrical current?

- (1) 0.1 M NaNO_3 (3) 0.01 M NaNO_3
 (2) 0.2 M NaNO_3 (4) 0.02 M NaNO_3

48 Given the equation representing a reaction:



This equation represents

- (1) sublimation (3) fission
 (2) condensation (4) fusion

49 Which formula represents 2-butene?

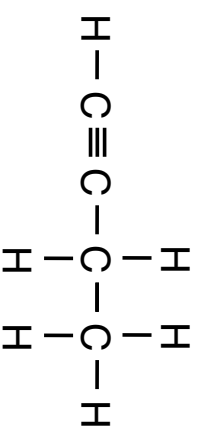
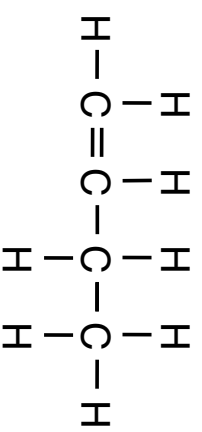

(1)

(3)

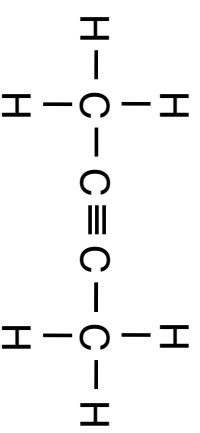
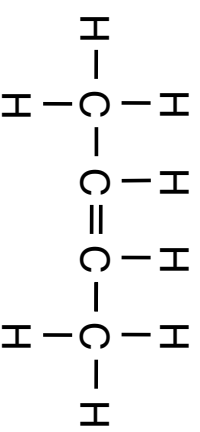

(2)

(4)

GO RIGHT ON TO THE NEXT PAGE ⇒

Part B-2

Answer all questions in this part.

Directions (51-65): Record your answers in the spaces provided in your answer booklet. Some questions may require the use of the *2011 Edition Reference Tables for Physical Setting/Chemistry*.

- 51 Explain, in terms of neutrons and protons, why P-32 and P-31 are different isotopes of phosphorus. [1]
- 52 Determine the oxidation state of chromium in K_2CrO_4 . [1]

Base your answers to questions 53 and 54 on the information below and on your knowledge of chemistry.

The first four elements in Group 14 are carbon, silicon, germanium, and tin. These elements form compounds with chlorine that have similar formulas. Two examples of these formulas are silicon tetrachloride, SiCl_4 , and germanium tetrachloride, GeCl_4 .

- 53 State the general trend in atomic radius as these four elements are considered in order of increasing atomic number. [1]
- 54 State, in terms of electron configuration, why silicon and germanium both form tetrachloride compounds. [1]
-

Base your answers to questions 55 through 57 on the information below and on your knowledge of chemistry.

The equation below represents the reaction between ammonia and hydrogen chloride.



- 55 Explain, in terms of distribution of charge, why a molecule of compound 1 is polar. [1]
- 56 Draw a Lewis electron-dot diagram for a molecule of compound 2. [1]
- 57 Identify the *two* types of chemical bonds in the product of this reaction. [1]
-

Base your answers to questions 58 through 60 on the information below and on your knowledge of chemistry.

A sample of helium gas, $\text{He}(\text{g})$, is placed in a rigid cylinder sealed with a movable piston. The temperature of the helium is 25.0°C . The volume of the helium is 300. milliliters and the pressure is 0.500 atmosphere.

- 58 State, in terms of the average distance between the helium atoms, why the density of the gas increases when the piston is pushed farther into the rigid cylinder. [1]

59 Determine the volume of the helium gas when the pressure is increased to 1.50 atm and the temperature remains at 25.0°C. [1]

60 Compare the number of helium atoms in the cylinder at a pressure of 0.500 atm to the number of helium atoms in the cylinder when the pressure is increased to 1.50 atm by pushing the piston in. [1]

Base your answers to questions 61 and 62 on the information below and on your knowledge of chemistry.

During a laboratory activity, a student places 21.0 mL of hydrochloric acid solution, $\text{HCl}(\text{aq})$, of unknown concentration into a flask. The solution is titrated with 0.125 M $\text{NaOH}(\text{aq})$ until the acid is exactly neutralized. The volume of $\text{NaOH}(\text{aq})$ added is 18.5 milliliters. During this laboratory activity, appropriate safety equipment is used and safety procedures are followed.

61 Explain, in terms of ions, why the hydrochloric acid solution can conduct an electric current. [1]

62 Determine the concentration of the $\text{HCl}(\text{aq})$ solution, using the titration data. [1]

Base your answers to questions 63 through 65 on the information below and on your knowledge of chemistry.

The table below lists the hydronium ion concentration and pH values of four different solutions and distilled water. The pH value is missing for sample 2.

Hydronium Concentration and pH Value for Five Samples

Sample Number	Sample Description	Hydronium Ion Concentration (M)	pH Value
1	0.1 M HCl(aq)	1×10^{-1}	1.0
2	0.01 M HCl(aq)	1×10^{-2}	?
3	distilled $\text{H}_2\text{O}(\ell)$	1×10^{-7}	7.0
4	0.01 M NaOH(aq)	1×10^{-12}	12.0
5	0.1 M NaOH(aq)	1×10^{-13}	13.0

- 63 Determine the pH value of sample 2. [1]
- 64 Identify the ion released by the compound dissolved in sample 4 that allows the compound to be classified as an Arrhenius base. [1]
- 65 State how many times greater the hydronium ion concentration is in sample 4 than it is in sample 5. [1]
-

Part C

Answer all questions in this part.

Directions (66-85): Record your answers in the spaces provided in your answer booklet. Some questions may require the use of the *2011 Edition Reference Tables for Physical Setting/Chemistry*.

Base your answers to questions 66 through 68 on the information below and on your knowledge of chemistry.

Boric acid, H_3BO_3 , is heated to produce tetraboric acid, $\text{H}_2\text{B}_4\text{O}_7$, and water. The equation below represents the reaction to form tetraboric acid.



The tetraboric acid is then used to make borax, which is used as a cleaning agent. Borax, $\text{Na}_2\text{B}_4\text{O}_7 \cdot 10\text{H}_2\text{O}$, is a hydrate with a gram-formula mass of 381 grams per mole. A hydrate is a compound with water within its crystal structure. Borax has ten moles of water for every mole of $\text{Na}_2\text{B}_4\text{O}_7$.

- 66 Explain why the formula for tetraboric acid is an empirical formula. [1]
- 67 Determine the number of moles of boric acid that react in the equation to produce 10 moles of water. [1]
- 68 Show a numerical setup for calculating the mass, in grams, of a 0.200-mole sample of borax. [1]

Base your answers to questions 69 through 71 on the information below and on your knowledge of chemistry.

During a laboratory activity, appropriate safety equipment is used and safety procedures are followed. A student uses the lab equipment shown in the diagram below to determine the heat of combustion of candle wax.

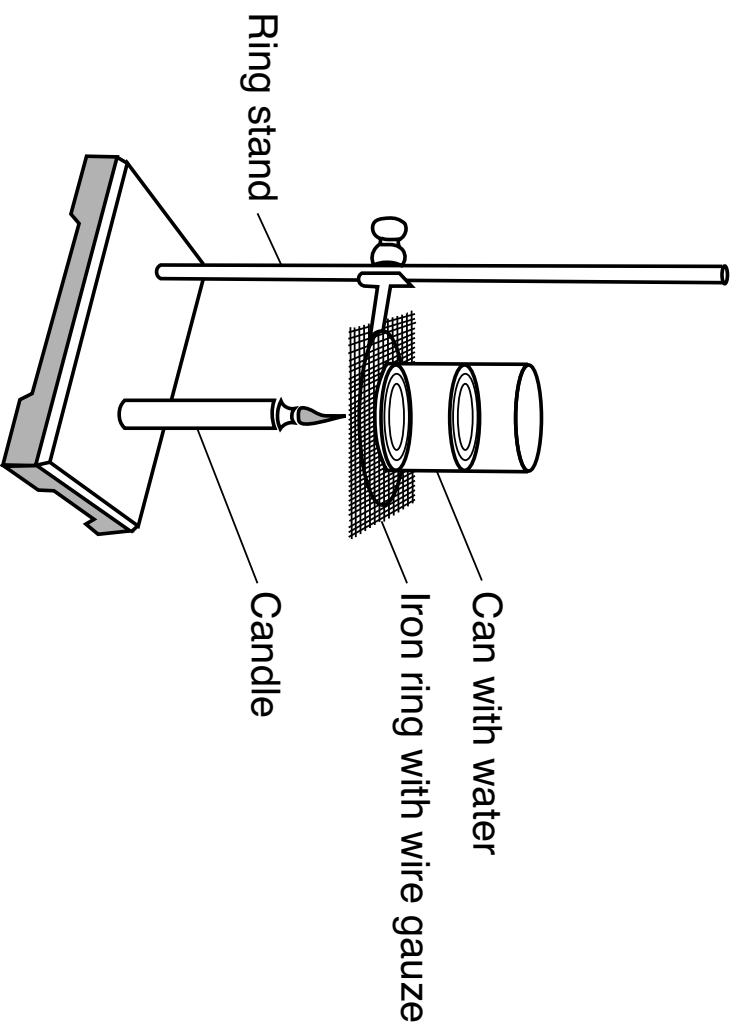

Questions 69 through 71 are continued on the next page.

Questions 69 through 71 continued

Heat of combustion is defined as the amount of heat released when a known mass of a substance is burned and can be measured in joules per gram. At the start of the activity, the mass of the candle and the mass of the water are measured. The starting temperature of the water is 5.0°C, and the air temperature in the room is 22.0°C. The candle is lit, and the water is stirred with a stirring rod. Several minutes later, the candle is extinguished, and the student measures the temperature of the water in the can. When the candle is cool, the student measures the final mass of the candle. Lab activity results are shown in the table below.

Lab Activity Results

Mass of Candle Wax Burned (g)	Mass of Water in the Can (g)	Calculated Temperature Change of Water (°C)	Heat Absorbed by the Water (J)	Calculated Heat of Combustion of Candle Wax (J/g)
0.83	190.	39	?	37 000

- 69 State the number of significant figures used to express the value for the mass of the water in the can. [1]
- 70 State the direction of the heat flow between the air and the water in the can before the candle is lit. [1]
- 71 Determine the amount of heat absorbed by the water. [1]
-

Base your answers to questions 72 through 76 on the information below and on your knowledge of chemistry.

A process was developed in 1912 to produce ammonia gas from atmospheric nitrogen gas and hydrogen gas. Iron can be used as a catalyst. The equation representing this system at equilibrium is shown below.

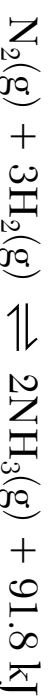

72 State evidence from the equation that the forward reaction is exothermic. [1]

73 Compare the rate of the forward reaction to the rate of the reverse reaction at equilibrium. [1]

74 On the labeled axes in *your answer booklet*, draw a potential energy diagram for the forward reaction represented in this equation. [1]

75 State, in terms of moles of gases, why the equilibrium shifts to the right due to an increase in pressure on the system at constant temperature. [1]

76 State what happens to the rate of forward reaction when the iron is added to this system. [1]

Base your answers to questions 77 through 79 on the information below and on your knowledge of chemistry.

Before the year 1828, it was thought that organic compounds were produced only by living organisms and that inorganic compounds were made from nonliving substances. Urea is an organic compound. In 1828, a chemist heated ammonium cyanate and produced urea, which is very soluble in water. The equation below represents this reaction.

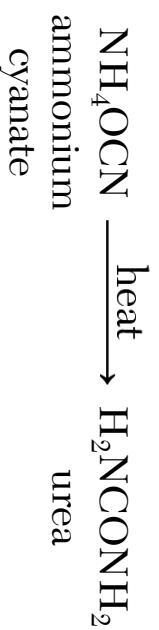

77 Identify the element present in urea that is present in all organic compounds. [1]

78 Compare the formula mass of the two compounds in the equation. [1]

79 State, in terms of molecular polarity, why urea is very soluble in water. [1]

Base your answers to questions 80 and 81 on the information below and on your knowledge of chemistry.

When a voltmeter is connected in the circuit of a voltaic cell, an electrical measurement called voltage can be read on the meter. The voltage of the cell is affected if the concentration of the solute in the half-cells is changed. The diagram, the ionic equation, and the graph below represent a copper-zinc cell. When the switch is closed, electricity flows through the circuit as the cell operates at constant temperature.

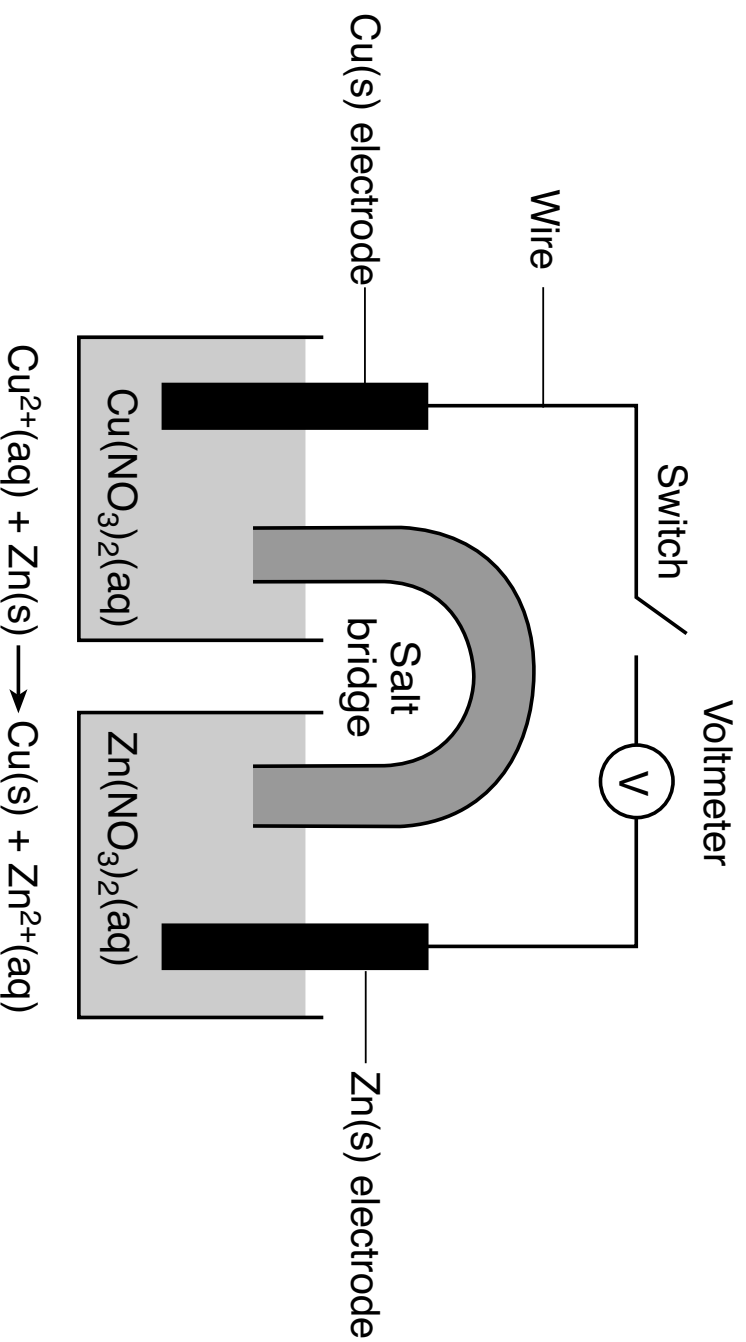

Questions 80 and 81 are continued on the next page.

Questions 80 and 81 continued

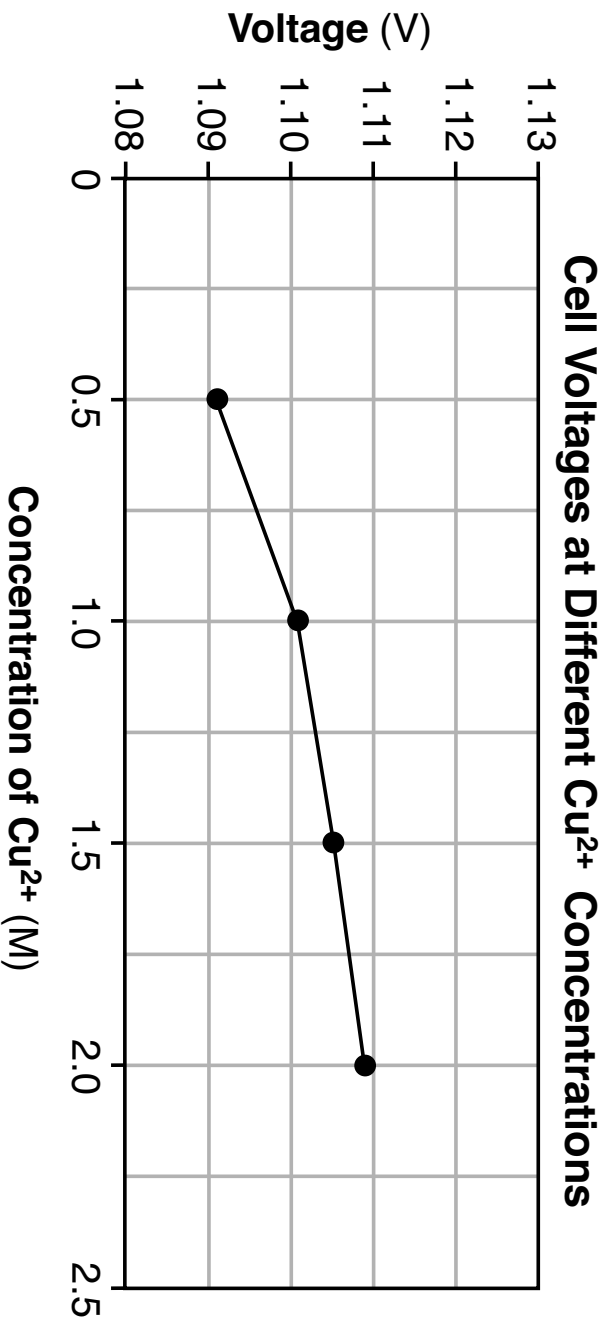

80 Based on the graph, determine the voltage of the cell if the $\text{Cu}(\text{NO}_3)_2(\text{aq})$ concentration is 1.5 M. [1]

81 Write a balanced half-reaction equation for the oxidation of zinc that occurs in this operating cell. [1]

Base your answers to questions 82 through 85 on the information below and on your knowledge of chemistry.

Synthetic radioisotopes may be made by bombarding other nuclides with neutrons. The equations below represent a sequence of reactions converting stable iron-58 to cobalt-60, which is used in medical treatments.



82 State the neutron to proton ratio for an atom of the ${}^{58}\text{Fe}$ in equation 1. [1]

83 State, in terms of elements, why equation 2 represents a transmutation reaction. [1]

84 Identify the particle represented by X in equation 3. [1]

85 Determine the fraction of an original sample of Co-60 that remains unchanged after 15.813 years. [1]
