

The University of the State of New York
REGENTS HIGH SCHOOL EXAMINATION

GEOMETRY

Wednesday, August 17, 2011—8:30 to 11:30 a.m., only

Student Name: _____

School Name: _____

Print your name and the name of your school on the lines above. Then turn to the last page of this booklet, which is the answer sheet for Part I. Fold the last page along the perforations and, slowly and carefully, tear off the answer sheet. Then fill in the heading of your answer sheet.

This examination has four parts, with a total of 38 questions. You must answer all questions in this examination. Write your answers to the Part I multiple-choice questions on the separate answer sheet. Write your answers to the questions in Parts II, III, and IV directly in this booklet. All work should be written in pen, except graphs and drawings, which should be done in pencil. Clearly indicate the necessary steps, including appropriate formula substitutions, diagrams, graphs, charts, etc.

The formulas that you may need to answer some questions in this examination are found at the end of the examination. This sheet is perforated so you may remove it from this booklet.

Scrap paper is not permitted for any part of this examination, but you may use the blank spaces in this booklet as scrap paper. A perforated sheet of scrap graph paper is provided at the end of this booklet for any question for which graphing may be helpful but is not required. You may remove this sheet from this booklet. Any work done on this sheet of scrap graph paper will *not* be scored.

When you have completed the examination, you must sign the statement printed at the end of the answer sheet, indicating that you had no unlawful knowledge of the questions or answers prior to the examination and that you have neither given nor received assistance in answering any of the questions during the examination. Your answer sheet cannot be accepted if you fail to sign this declaration.

Notice...

A graphing calculator, a straightedge (ruler), and a compass must be available for you to use while taking this examination.

The use of any communications device is strictly prohibited when taking this examination. If you use any communications device, no matter how briefly, your examination will be invalidated and no score will be calculated for you.

DO NOT OPEN THIS EXAMINATION BOOKLET UNTIL THE SIGNAL IS GIVEN.

Part I

Answer all 28 questions in this part. Each correct answer will receive 2 credits. No partial credit will be allowed. For each question, write on the separate answer sheet the numeral preceding the word or expression that best completes the statement or answers the question. [56]

Use this space for computations.

- 1 The statement “ x is a multiple of 3, and x is an even integer” is true when x is equal to
- (1) 9 (3) 3
(2) 8 (4) 6

- 2 In the diagram below, $\triangle ABC \cong \triangle XYZ$.

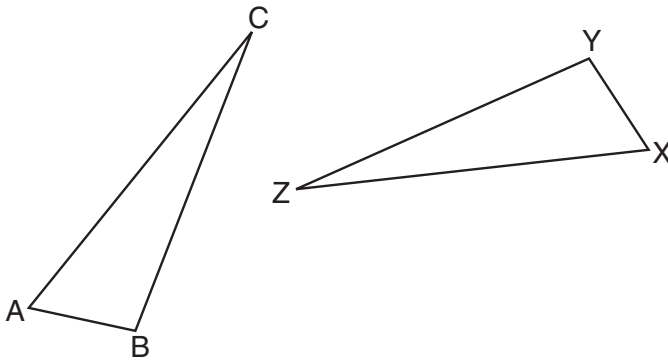

Which statement must be true?

- (1) $\angle C \cong \angle Y$ (3) $\overline{AC} \cong \overline{YZ}$
(2) $\angle A \cong \angle X$ (4) $\overline{CB} \cong \overline{XZ}$

Use this space for computations.

- 3 In the diagram below of $\triangle ABC$, $\overleftrightarrow{TV} \parallel \overline{BC}$, $AT = 5$, $TB = 7$, and $AV = 10$.

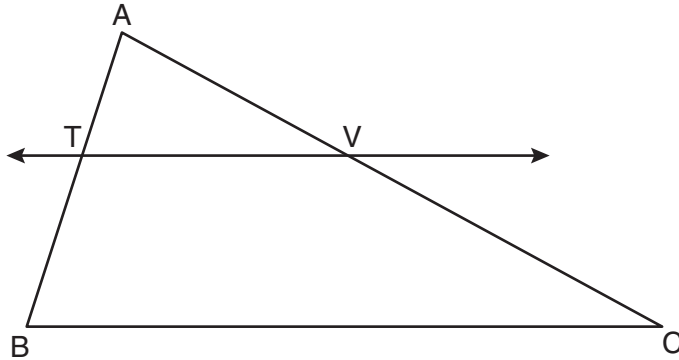

What is the length of \overline{VC} ?

- (1) $3\frac{1}{2}$ (2) $7\frac{1}{7}$ (3) 14 (4) 24
- 4 Pentagon $PQRST$ has \overline{PQ} parallel to \overline{TS} . After a translation of $T_{2, -5}$, which line segment is parallel to $\overline{P'Q'}$?
- (1) $\overline{R'Q'}$ (2) $\overline{R'S'}$ (3) $\overline{T'S'}$ (4) $\overline{T'P'}$

Use this space for computations.

- 5 In the diagram below of $\triangle PAO$, \overline{AP} is tangent to circle O at point A , $OB = 7$, and $BP = 18$.

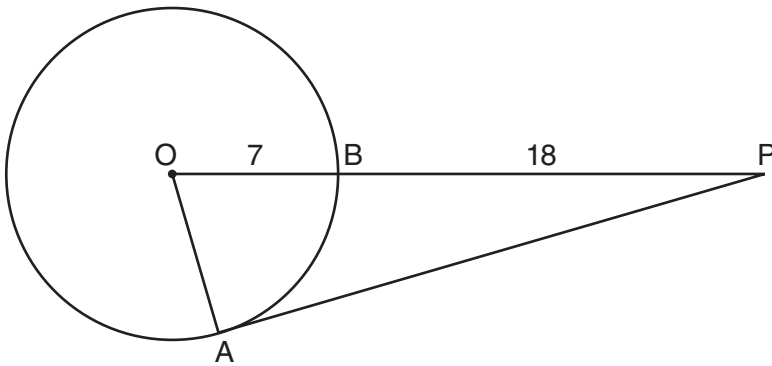

What is the length of \overline{AP} ?

- (1) 10 (3) 17
(2) 12 (4) 24

- 6 A straightedge and compass were used to create the construction below. Arc EF was drawn from point B , and arcs with equal radii were drawn from E and F .

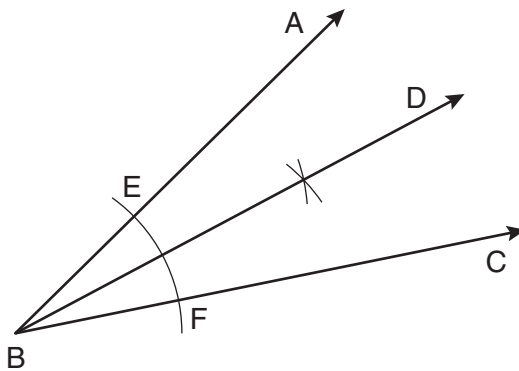

Which statement is *false*?

- (1) $m\angle ABD = m\angle DBC$
(2) $\frac{1}{2}(m\angle ABC) = m\angle ABD$
(3) $2(m\angle DBC) = m\angle ABC$
(4) $2(m\angle ABC) = m\angle CBD$

**Use this space for
computations.**

7 What is the length of the line segment whose endpoints are $(1, -4)$ and $(9, 2)$?

(1) 5

(3) 10

(2) $2\sqrt{17}$

(4) $2\sqrt{26}$

8 What is the image of the point $(2, -3)$ after the transformation $r_{y\text{-axis}}$?

(1) $(2, 3)$

(3) $(-2, 3)$

(2) $(-2, -3)$

(4) $(-3, 2)$

Use this space for
computations.

9 In the diagram below, lines n and m are cut by transversals p and q .

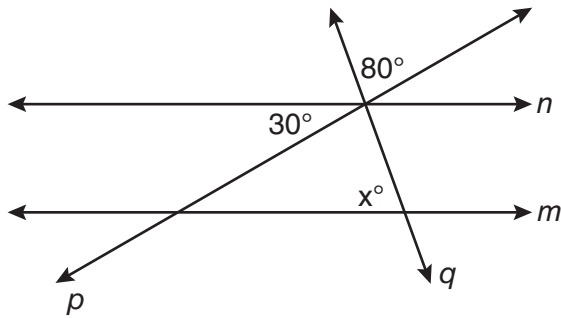

Which value of x would make lines n and m parallel?

- (1) 110
- (2) 80
- (3) 70
- (4) 50

10 What is an equation of the circle with a radius of 5 and center at $(1, -4)$?

- (1) $(x + 1)^2 + (y - 4)^2 = 5$
- (2) $(x - 1)^2 + (y + 4)^2 = 5$
- (3) $(x + 1)^2 + (y - 4)^2 = 25$
- (4) $(x - 1)^2 + (y + 4)^2 = 25$

Use this space for
computations.

- 11 In the diagram below of $\triangle BCD$, side \overline{DB} is extended to point A.

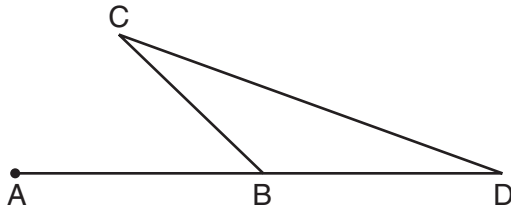

Which statement must be true?

- (1) $m\angle C > m\angle D$ (3) $m\angle ABC > m\angle C$
(2) $m\angle ABC < m\angle D$ (4) $m\angle ABC > m\angle C + m\angle D$
- 12 Which equation represents the line parallel to the line whose equation is $4x + 2y = 14$ and passing through the point $(2,2)$?
- (1) $y = -2x$ (3) $y = \frac{1}{2}x$
(2) $y = -2x + 6$ (4) $y = \frac{1}{2}x + 1$
- 13 The coordinates of point A are $(-3a, 4b)$. If point A' is the image of point A reflected over the line $y = x$, the coordinates of A' are
- (1) $(4b, -3a)$ (3) $(-3a, -4b)$
(2) $(3a, 4b)$ (4) $(-4b, -3a)$

Use this space for
computations.

14 As shown in the diagram below, \overline{AC} bisects $\angle BAD$ and $\angle B \cong \angle D$.

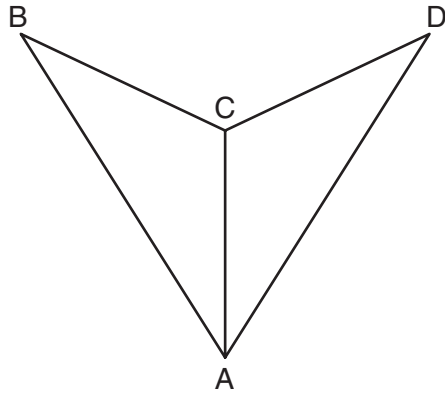

Which method could be used to prove $\triangle ABC \cong \triangle ADC$?

- | | |
|---------|---------|
| (1) SSS | (3) SAS |
| (2) AAA | (4) AAS |

15 Segment AB is the diameter of circle M . The coordinates of A are $(-4,3)$. The coordinates of M are $(1,5)$. What are the coordinates of B ?

- | | |
|-------------|--------------|
| (1) $(6,7)$ | (3) $(-3,8)$ |
| (2) $(5,8)$ | (4) $(-5,2)$ |

Use this space for
computations.

16 In the diagram below, \overleftrightarrow{AB} is perpendicular to plane $AEFG$.

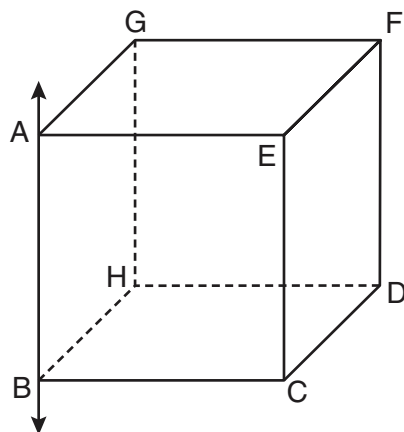

Which plane must be perpendicular to plane $AEFG$?

- | | |
|------------|------------|
| (1) $ABCE$ | (3) $CDFE$ |
| (2) $BCDH$ | (4) $HDFG$ |

17 How many points are both 4 units from the origin and also 2 units from the line $y = 4$?

- | | |
|-------|-------|
| (1) 1 | (3) 3 |
| (2) 2 | (4) 4 |

Use this space for computations.

- 18** When solved graphically, what is the solution to the following system of equations?

$$y = x^2 - 4x + 6$$

$$y = x + 2$$

- | | |
|-----------|---------------------|
| (1) (1,4) | (3) (1,3) and (4,6) |
| (2) (4,6) | (4) (3,1) and (6,4) |
- 19** Triangle PQR has angles in the ratio of 2:3:5. Which type of triangle is $\triangle PQR$?
- | | |
|---------------|------------|
| (1) acute | (3) obtuse |
| (2) isosceles | (4) right |

**Use this space for
computations.**

20 Plane \mathcal{A} is parallel to plane \mathcal{B} . Plane \mathcal{C} intersects plane \mathcal{A} in line m and intersects plane \mathcal{B} in line n . Lines m and n are

- (1) intersecting (3) perpendicular
(2) parallel (4) skew

21 The diagonals of a quadrilateral are congruent but do *not* bisect each other. This quadrilateral is

- (1) an isosceles trapezoid (3) a rectangle
(2) a parallelogram (4) a rhombus

22 What is the slope of a line perpendicular to the line represented by the equation $x + 2y = 3$?

- (1) -2 (3) $-\frac{1}{2}$
(2) 2 (4) $\frac{1}{2}$

Use this space for computations.

- 23** A packing carton in the shape of a triangular prism is shown in the diagram below.

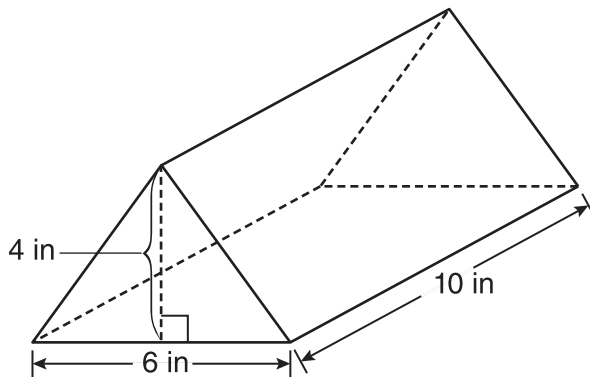

What is the volume, in cubic inches, of this carton?

- (1) 20 (3) 120
 (2) 60 (4) 240
- 24** In the diagram below of circle O , diameter \overline{AOB} is perpendicular to chord \overline{CD} at point E , $OA = 6$, and $OE = 2$.

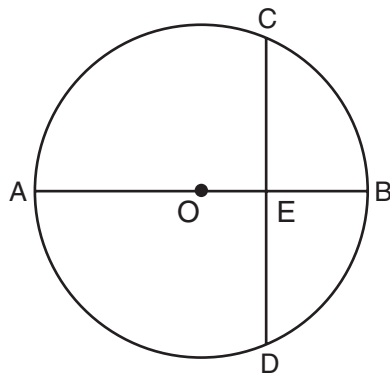

What is the length of \overline{CE} ?

- (1) $4\sqrt{3}$ (3) $8\sqrt{2}$
 (2) $2\sqrt{3}$ (4) $4\sqrt{2}$

Use this space for computations.

25 What is the measure of each interior angle of a regular hexagon?

- (1) 60° (3) 135°
(2) 120° (4) 270°

26 Which equation represents the perpendicular bisector of \overline{AB} whose endpoints are $A(8,2)$ and $B(0,6)$?

- (1) $y = 2x - 4$ (3) $y = -\frac{1}{2}x + 6$
(2) $y = -\frac{1}{2}x + 2$ (4) $y = 2x - 12$

27 As shown in the diagram below, a kite needs a vertical and a horizontal support bar attached at opposite corners. The upper edges of the kite are 7 inches, the side edges are x inches, and the vertical support bar is $(x + 1)$ inches.

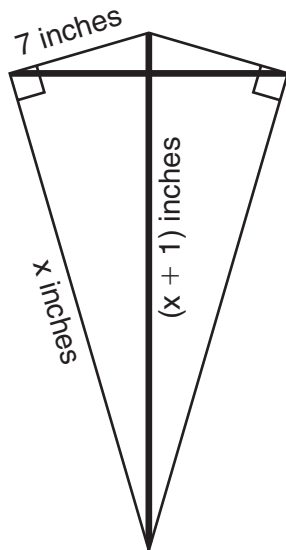

What is the measure, in inches, of the vertical support bar?

- (1) 23 (3) 25
(2) 24 (4) 26

**Use this space for
computations.**

28 Given three distinct quadrilaterals, a square, a rectangle, and a rhombus, which quadrilaterals must have perpendicular diagonals?

- (1) the rhombus, only
 - (2) the rectangle and the square
 - (3) the rhombus and the square
 - (4) the rectangle, the rhombus, and the square
-

Part II

Answer all 6 questions in this part. Each correct answer will receive 2 credits. Clearly indicate the necessary steps, including appropriate formula substitutions, diagrams, graphs, charts, etc. For all questions in this part, a correct numerical answer with no work shown will receive only 1 credit. All answers should be written in pen, except for graphs and drawings, which should be done in pencil. [12]

- 29 In the diagram below, trapezoid $ABCD$, with bases \overline{AB} and \overline{DC} , is inscribed in circle O , with diameter \overline{DC} . If $m\widehat{AB} = 80$, find $m\widehat{BC}$.

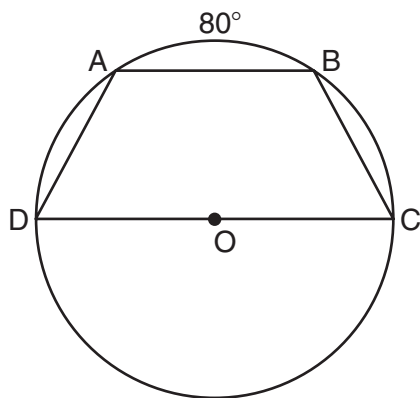

30 On the diagram of $\triangle ABC$ shown below, use a compass and straightedge to construct the perpendicular bisector of \overline{AC} . [Leave all construction marks.]

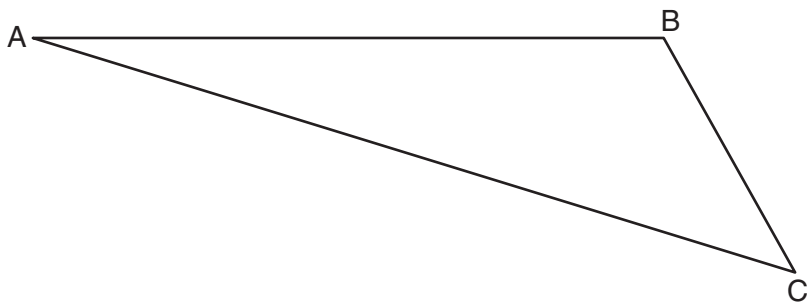

31 A sphere has a diameter of 18 meters. Find the volume of the sphere, in cubic meters, in terms of π .

32 Write an equation of the circle graphed in the diagram below.

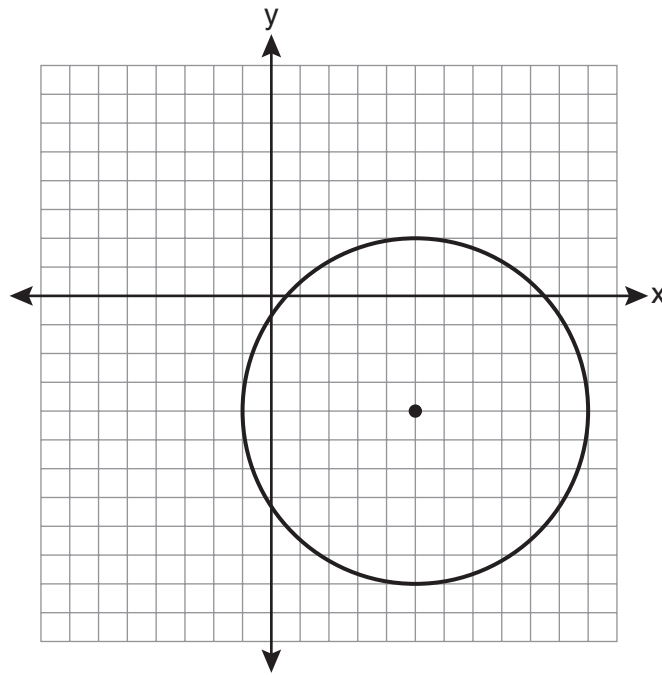

33 The diagram below shows $\triangle ABC$, with \overline{AEB} , \overline{ADC} , and $\angle ACB \cong \angle AED$. Prove that $\triangle ABC$ is similar to $\triangle ADE$.

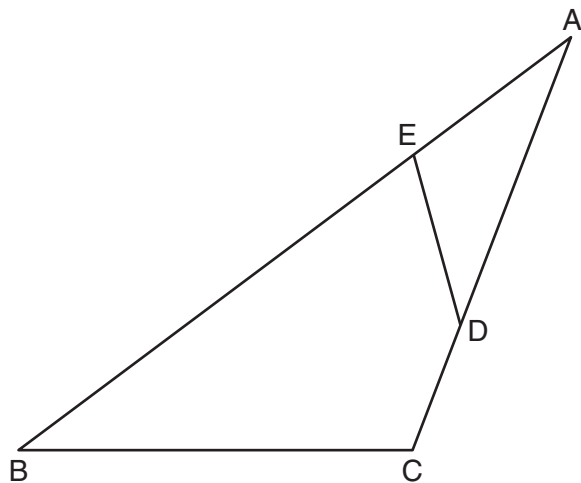

34 Triangle ABC has vertices $A(3,3)$, $B(7,9)$, and $C(11,3)$. Determine the point of intersection of the medians, and state its coordinates. [The use of the set of axes below is optional.]

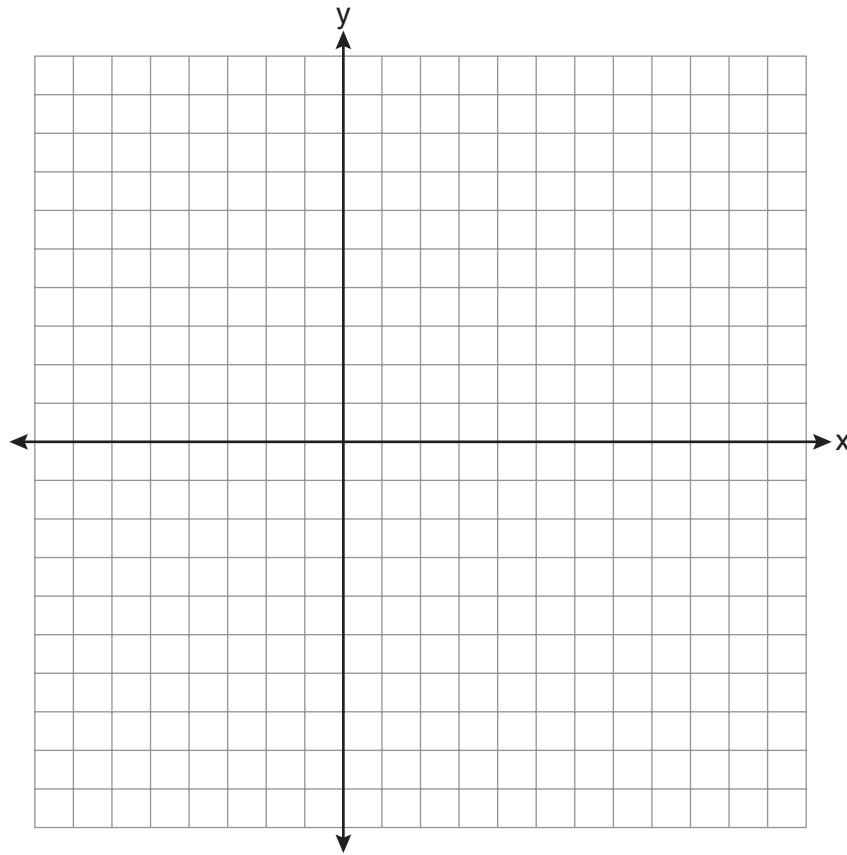

Part III

Answer all 3 questions in this part. Each correct answer will receive 4 credits. Clearly indicate the necessary steps, including appropriate formula substitutions, diagrams, graphs, charts, etc. For all questions in this part, a correct numerical answer with no work shown will receive only 1 credit. All answers should be written in pen, except for graphs and drawings, which should be done in pencil. [12]

- 35 In the diagram below of $\triangle GJK$, H is a point on \overline{GJ} , $\overline{HJ} \cong \overline{JK}$, $m\angle G = 28$, and $m\angle GJK = 70$. Determine whether $\triangle GHK$ is an isosceles triangle and justify your answer.

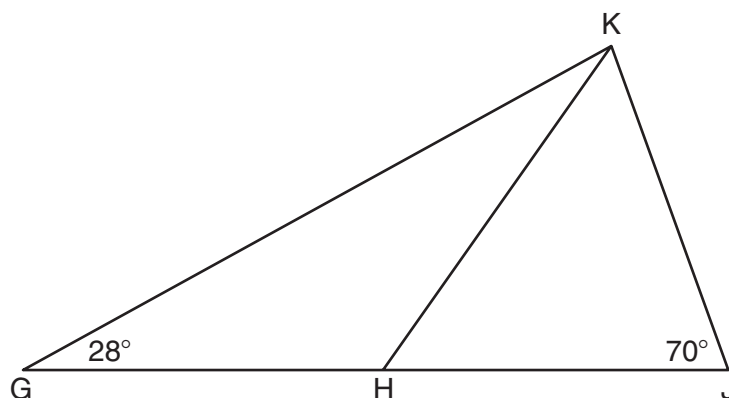

- 36 As shown on the set of axes below, $\triangle GHS$ has vertices $G(3,1)$, $H(5,3)$, and $S(1,4)$. Graph and state the coordinates of $\triangle G''H''S''$, the image of $\triangle GHS$ after the transformation $T_{-3,1} \circ D_2$.

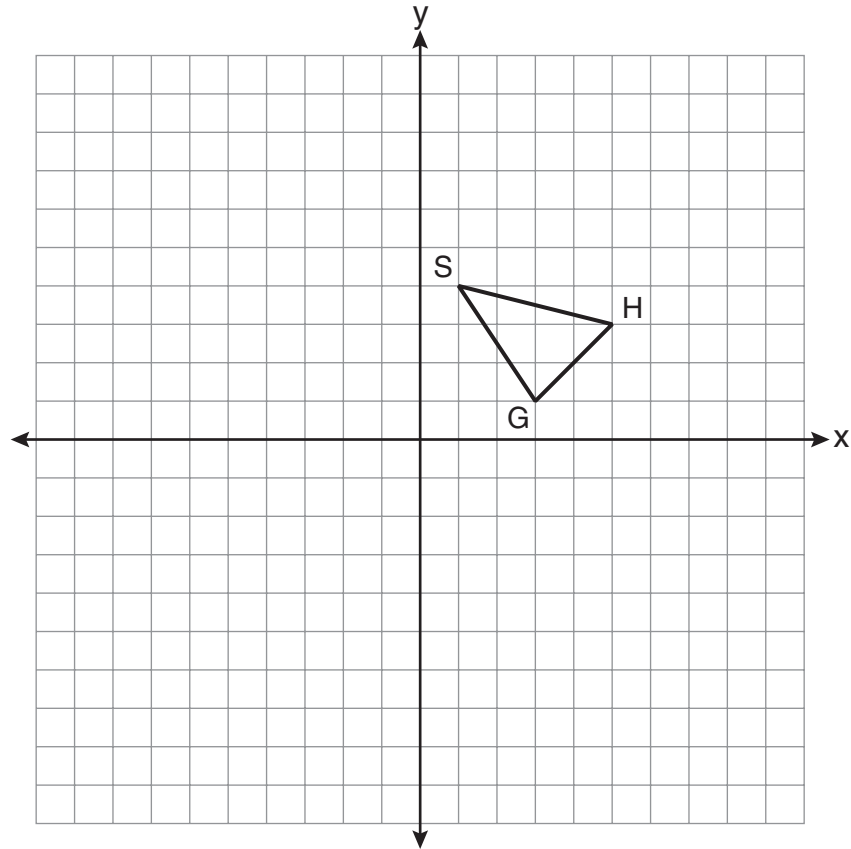

37 In the diagram below, $\triangle ABC \sim \triangle DEF$, $DE = 4$, $AB = x$, $AC = x + 2$, and $DF = x + 6$. Determine the length of \overline{AB} . [Only an algebraic solution can receive full credit.]

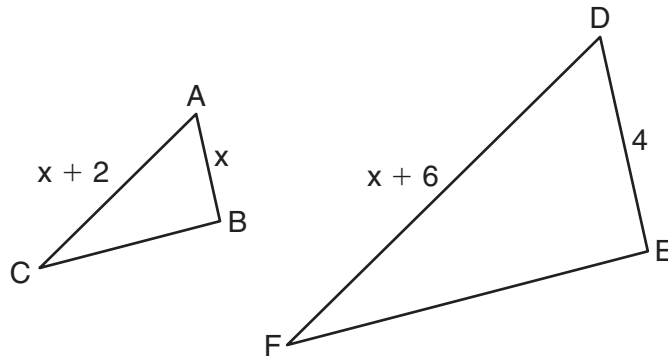

Part IV

Answer the question in this part. A correct answer will receive 6 credits. Clearly indicate the necessary steps, including appropriate formula substitutions, diagrams, graphs, charts, etc. A correct numerical answer with no work shown will receive only 1 credit. The answer should be written in pen. [6]

38 Given: $\triangle ABC$ with vertices $A(-6, -2)$, $B(2, 8)$, and $C(6, -2)$
 \overline{AB} has midpoint D , \overline{BC} has midpoint E , and \overline{AC} has midpoint F

Prove: $ADEF$ is a parallelogram

$ADEF$ is *not* a rhombus

[The use of the grid below is optional.]

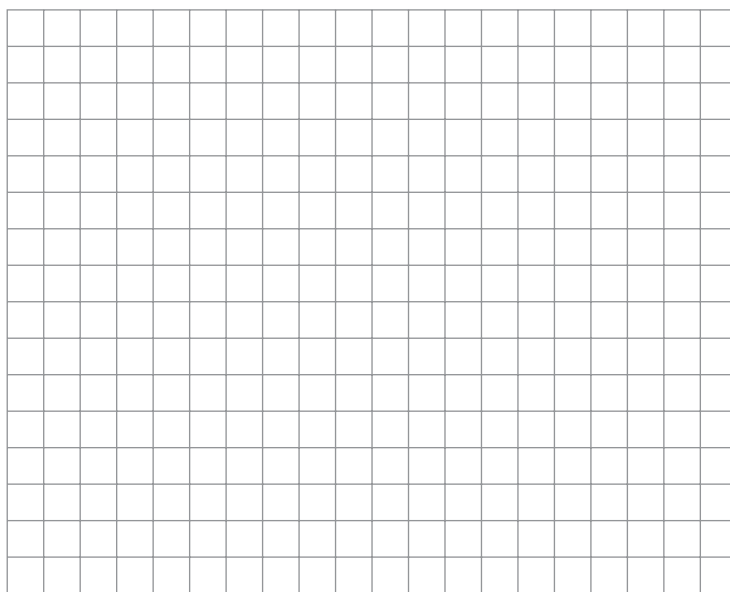

Reference Sheet

Tear Here

| | | |
|--------|---------------------|--|
| Volume | Cylinder | $V = Bh$ where B is the area of the base |
| | Pyramid | $V = \frac{1}{3}Bh$ where B is the area of the base |
| | Right Circular Cone | $V = \frac{1}{3}Bh$ where B is the area of the base |
| | Sphere | $V = \frac{4}{3}\pi r^3$ |

| | | |
|----------------------|-------------------------|---|
| Lateral Area (L) | Right Circular Cylinder | $L = 2\pi rh$ |
| | Right Circular Cone | $L = \pi rl$ where l is the slant height |

| | | |
|--------------|--------|-----------------|
| Surface Area | Sphere | $SA = 4\pi r^2$ |
|--------------|--------|-----------------|

Tear Here

Tear Here

Tear Here

Scrap Graph Paper — This sheet will *not* be scored.

Tear Here

Tear Here

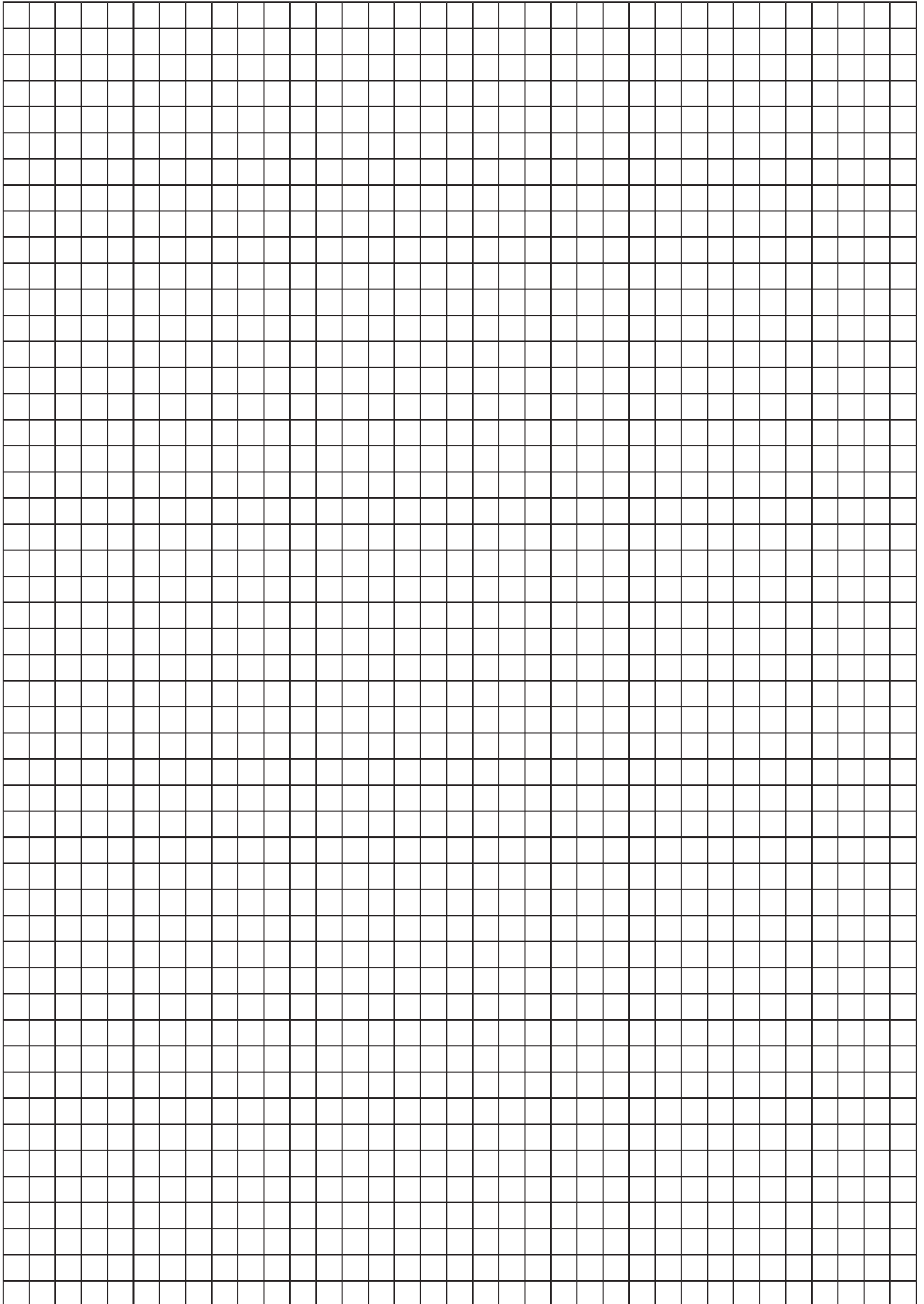

Scrap Graph Paper — This sheet will *not* be scored.

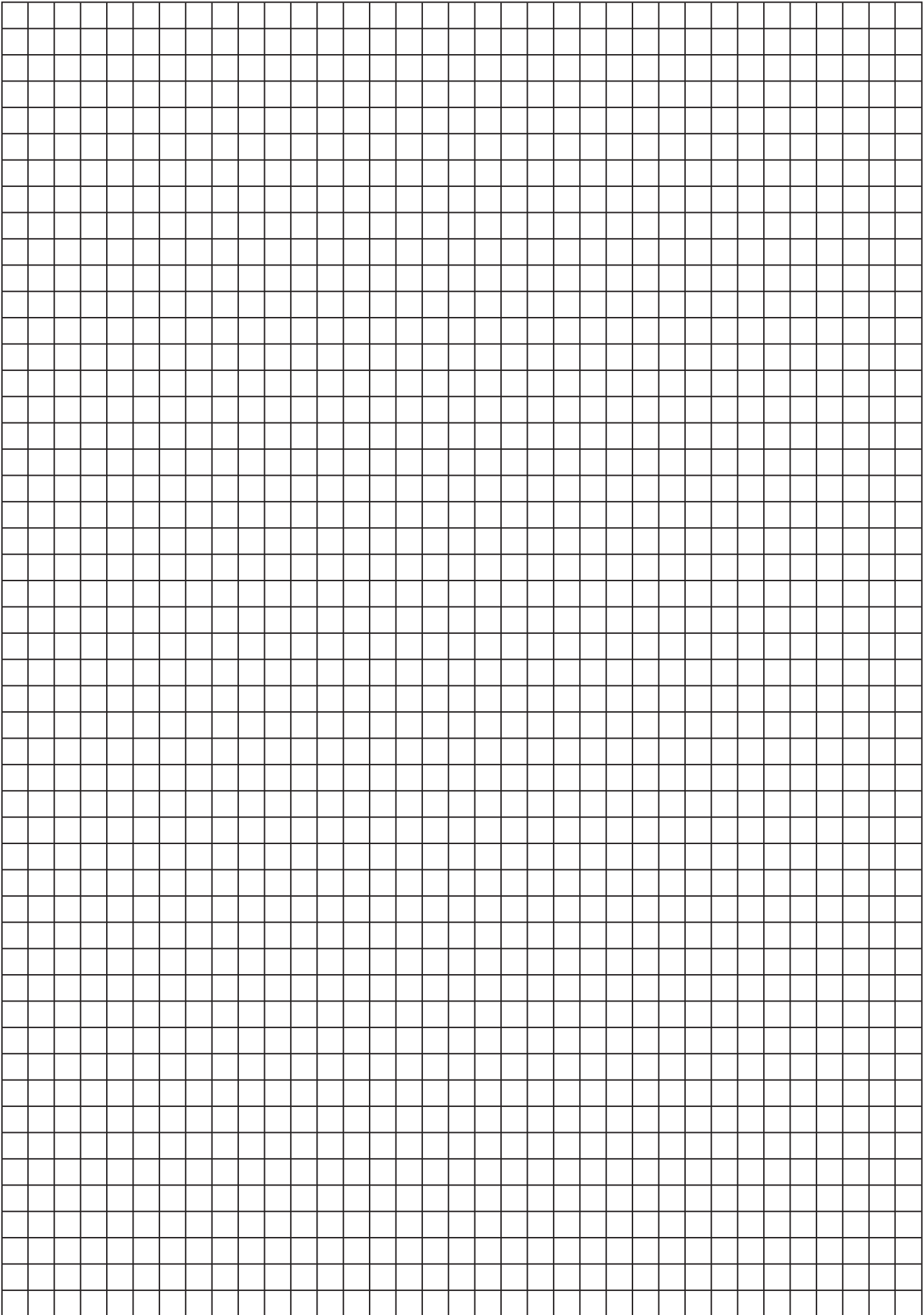

Tear Here

Tear Here

The University of the State of New York
REGENTS HIGH SCHOOL EXAMINATION

GEOMETRY

Wednesday, August 17, 2011—8:30 to 11:30 a.m., only

ANSWER SHEET

Student Sex: Male Female Grade

Teacher School

Your answers to Part I should be recorded on this answer sheet.

Part I

Answer all 28 questions in this part.

- | | | | |
|---------|----------|----------|----------|
| 1 | 8 | 15 | 22 |
| 2 | 9 | 16 | 23 |
| 3 | 10 | 17 | 24 |
| 4 | 11 | 18 | 25 |
| 5 | 12 | 19 | 26 |
| 6 | 13 | 20 | 27 |
| 7 | 14 | 21 | 28 |

Your answers for Parts II, III, and IV should be written in the test booklet.

The declaration below must be signed when you have completed the examination.

I do hereby affirm, at the close of this examination, that I had no unlawful knowledge of the questions or answers prior to the examination and that I have neither given nor received assistance in answering any of the questions during the examination.

Signature

GEOMETRY

| GEOMETRY | | | |
|----------------------|----------------|----------------|---------------------------|
| Question | Maximum Credit | Credits Earned | Rater's/Scorer's Initials |
| Part I 1–28 | 56 | | |
| Part II 29 | 2 | | |
| 30 | 2 | | |
| 31 | 2 | | |
| 32 | 2 | | |
| 33 | 2 | | |
| 34 | 2 | | |
| Part III 35 | 4 | | |
| 36 | 4 | | |
| 37 | 4 | | |
| Part IV 38 | 6 | | |
| Maximum Total | 86 | | |

| |
|--|
| Rater's/Scorer's Name (minimum of three) |
| |
| |
| |
| |
| |
| |
| |
| |
| |
| |
| |
| |
| |
| |

Tear Here

Total Raw Score **Checked by**

| |
|--|
| |
|--|

Scale Score
(from conversion chart)

Tear Here