



Our Students. Their Moment.

**New York State Testing Program
Grade 6 Common Core
Mathematics Test**

Released Questions with Annotations

August 2013



THE STATE EDUCATION DEPARTMENT / THE UNIVERSITY OF THE STATE OF NEW YORK /
ALBANY, NY 12234

New York State Testing Program Grade 6 Common Core Mathematics Test

Released Questions with Annotations

With the adoption of the New York P-12 Common Core Learning Standards (CCLS) in ELA/Literacy and Mathematics, the Board of Regents signaled a shift in both instruction and assessment. In Spring 2013, New York State administered the first set of tests designed to assess student performance in accordance with the instructional shifts and the rigor demanded by the Common Core State Standards (CCSS). To aid in the transition to new tests, New York State released a number of resources during the 2012-2013 year, including test blueprints and specifications, and criteria for writing test questions. These resources can be found at <http://www.engageny.org/common-core-assessments>.

New York State administered the first ELA/Literacy and Mathematics Common Core tests in April 2013 and is now making a portion of the questions from those tests available for review and use. These released questions will help students, families, educators, and the public better understand how tests have changed to assess the instructional shifts demanded by the Common Core and to assess the rigor required to ensure that all students are on track to college and career readiness.

Annotated Questions Are Teaching Tools

The released questions are intended to help students, families, educators, and the public understand how the Common Core is different. The annotated questions will demonstrate the way the Common Core should drive instruction and how tests have changed to better assess student performance in accordance with the instructional shifts demanded by the Common Core. They are also intended to help educators identify how the rigor of the State tests can inform classroom instruction and local assessment. The annotations will indicate common student misunderstandings related to content standards; educators should use these to help inform unit and lesson planning. In some cases, the annotations may offer insight into particular instructional elements (conceptual thinking, visual models) that align to the Common Core that may be used in curricular design. It should not be assumed, however, that a particular standard will be measured with an identical item in future assessments.

The annotated questions will include both multiple-choice and constructed-response questions. With each multiple-choice question released, a rationale will be available to demonstrate why the question measures the intended standards; why the correct answer is correct; and why each wrong answer is plausible but incorrect. The rationales describe why the wrong answer choices are plausible but incorrect and are based in common errors in computation. While these rationales will speak to a possible and likely reason for selection of the incorrect option by the student, these rationales do not contain definitive statements as to why the student chose the incorrect option or what we can infer about knowledge and skills of the student based on their selection of an incorrect response. These multiple-choice questions are designed to assess student proficiency, not to diagnose specific misconceptions/errors with each and every incorrect option.

Additionally, for each constructed-response question, there will be an explanation for why the question measures the intended standards and sample student responses representing each possible score point.

Questions from the upper grades may feature more detailed annotations, as the items tend to be more complex.

Understanding Math Annotated Questions

Multiple Choice

Multiple-choice questions are designed to assess CCLS for Mathematics. Mathematics multiple-choice questions will mainly be used to assess standard algorithms and conceptual standards. Multiple-choice questions incorporate both Standards and Standards for Mathematical Practices, some in real-world applications. Many multiple-choice questions require students to complete multiple steps. Likewise, many of these questions are linked to more than one standard, drawing on the simultaneous application of multiple skills and concepts. Within answer choices, distractors will all be based on plausible missteps.

Short and extended constructed-response questions may refer to the scoring rubric, which can be found at www.engageny.org/resource/test-guides-for-english-language-arts-and-mathematics.

Short Response

Short-response questions are similar to past 2-point questions, requiring students to complete a task and show their work. Like multiple-choice questions, short-response questions will often require multiple steps, the application of multiple mathematics skills, and real-world applications. Many of the short-response questions will cover conceptual and application Standards.

Extended Response

Extended-response questions are similar to past 3-point questions, asking students to show their work in completing two or more tasks or a more extensive problem. Extended-response questions allow students to show their understanding of mathematical procedures, conceptual understanding, and application. Extended-response questions may also assess student reasoning and the ability to critique the arguments of others.

Released Questions Do Not Comprise a Mini Test

This document is NOT intended to show how operational tests look or to provide information about how teachers should administer the test; rather, the purpose of the released questions is to provide an overview of how the new test reflects the demands of the Common Core.

The released questions do not represent the full spectrum of standards assessed on the State test, nor do they represent the full spectrum of how the Common Core should be taught and assessed in the classroom. Specific criteria for writing test questions as well as additional test information is available at www.engageny.org/common-core-assessments.

124060034_2

Evaluate:

$$6^3 + 7 \times 4$$

A 100

B 244

C 757

D 892

Key: B

Aligned CCLS: 6.EE.1

Commentary: This item measures 6.EE.1 because it requires students to evaluate a numerical expression involving whole number exponents.

Extended Rationale

Answer Choice A: "100" This response is incorrect and may occur when the student evaluates the exponent as 6 multiplied by 3 and incorrectly continues to perform operations from left to right.

$$(18 + 7) \times 4 = 25 \times 4 = 100$$

A student who selects this response may not yet understand how to perform operations in the appropriate order in this type of expression.

Answer Choice B: "244" The student has correctly evaluated the numerical expression involving whole number exponents and carried out the correct order of operations.

$$6^3 + 7 \times 4 = 216 + 28 = 244$$

Answer Choice C: "757" This response is incorrect and may occur when the student evaluates the exponent as 3 times itself 6 times (that is, $3 \times 3 \times 3 \times 3 \times 3 \times 3$) rather than 6 times itself three times ($6 \times 6 \times 6$).

$$729 + 7 \times 4 = 729 + 28 = 757$$

A student who selects this response may not yet understand how to evaluate a whole number exponent.

Answer Choice D: "892" This response is incorrect and may occur when the student correctly applies the whole number exponent, but evaluates from left to right without following the order of operations.

$$(216 + 7) \times 4 = 223 \times 4 = 892$$

A student who selects this response may not yet understand how to perform operations in the appropriate order in this type of expression.

Answer options A, C, and D are plausible but incorrect. They are based on conceptual errors made when a student is evaluating a numerical expression involving whole number exponents.

Which pair of expressions is equivalent?

- A $4(6x)$ and $10x$
- B $4(6x)$ and $24x$
- C $4x + 6x$ and $10x^2$
- D $4x + 6x$ and $24x$

Key: B

Aligned CCLS: 6.EE.4

Commentary: This item measures 6.EE.4 because students are required to identify when two expressions are equivalent; expressions are equivalent when they name the same number, regardless of which value is substituted into them.

Extended Rationale

Answer Choice A: " $4(6x)$ and $10x$ " This response is incorrect and may occur when a student confuses $4(6x)$ as the sum of 4 and $6x$ and incorrectly combines terms. This student also may not recognize that for many values that can be substituted for x , these expressions do not name the same number.

Answer Choice B: " $4(6x)$ and $24x$ " The student has correctly identified the equivalent expressions. The student may have correctly multiplied 4 by $6x$ to get $24x$. The student may also have determined the equivalence of the two expressions by evaluating them both with the same value of x . For example, if $x = 2$, then $4(6x) = 4(6 \times 2) = 4(12) = 48$ and $24x = 24 \times 2 = 48$. This could be repeated several times, with other values of x , to informally verify that the expressions consistently name the same number.

Answer Choice C: " $4x + 6x$ and $10x^2$ " This response is incorrect and may occur when a student erroneously adds the exponents of the variable when combining like terms. The sum of $4x$ and $6x$ is $10x$, not $10x^2$. This student also may not recognize that for many values that can be substituted for x , these expressions do not name the same number.

Answer Choice D: " $4x + 6x$ and $24x$ " This response is incorrect and may occur when a student incorrectly multiplies the coefficients of the terms rather than adds them. This student also may not recognize that for many values that can be substituted for x , these expressions do not name the same number.

Answer options A, C, and D are plausible but incorrect. They are based on conceptual errors made when a student is applying properties of operations to generate equivalent expressions.

The length of a rectangular parking lot at the airport is $\frac{2}{3}$ mile. If the area is $\frac{1}{2}$ square mile, what is the width of the parking lot?

- A $\frac{1}{3}$ mile
- B $\frac{3}{4}$ mile
- C $1\frac{1}{6}$ miles
- D $1\frac{1}{3}$ miles

Key: B

Aligned CCLS: 6.NS.1

Commentary: This item measures 6.NS.1 because it requires the student to interpret and solve a word problem involving division of a fraction by a fraction.

Extended Rationale

Answer Choice A: " $\frac{1}{3}$ mile" This response is incorrect and may occur when a student selects an incorrect operation based on the question in the word problem. The student uses multiplication ($\frac{2}{3} \times \frac{1}{2} = \frac{2}{6} = \frac{1}{3}$) rather than division to solve the word problem.

Answer Choice B: " $\frac{3}{4}$ mile" The student has correctly interpreted the word problem and applied the area for a rectangle ($A = lw$) to find the width of the parking lot. The student divided the total area by the given length in order to find the width of the parking lot:

$$\frac{1}{2} \div \frac{2}{3} = \frac{1}{2} \times \frac{3}{2} = \frac{3}{4}$$

Answer Choice C: " $1\frac{1}{6}$ miles" This response is incorrect and may occur when a student selects an incorrect operation based on the question in the word problem. The student may have used addition ($\frac{1}{2} + \frac{2}{3} = \frac{3}{6} + \frac{4}{6} = \frac{7}{6} = 1\frac{1}{6}$) rather than division to solve the word problem.

Answer Choice D: " $1\frac{1}{3}$ miles" This response is incorrect and may occur when a student confuses the divisor with the dividend. A student who selects this response may have some understanding of computing quotients of fractions. However, there may be a lack of conceptual understanding of how to interpret word problems involving the division of a fraction by a fraction. The student also may have applied the formula for the area of a rectangle incorrectly either in the creation of an equation or the evaluation and solving of that equation.

Answer options A, C, and D are plausible but incorrect. They are based on a conceptual misunderstanding of how to interpret and compute fractions, and solve a word problem involving division of a fraction by a fraction.

What is the area of the isosceles trapezoid shown?

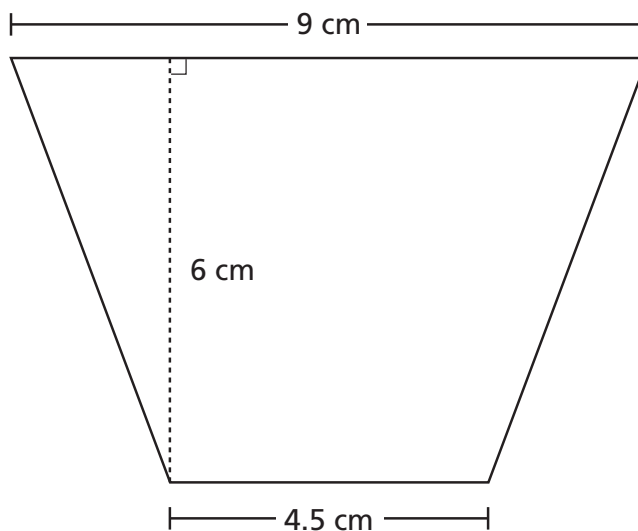

- A 27 cm^2
- B 33.8 cm^2
- C 40.5 cm^2
- D 54 cm^2

Key: C

Aligned CCLS: 6.G.1

Commentary: This item measures 6.G.1 because it requires the student to find the area of a special quadrilateral, an isosceles trapezoid, by decomposing it into two triangles and a rectangle.

Extended Rationale

Answer Choice A: “ 27 cm^2 ” This response is incorrect and may occur when the student only calculates the area of a rectangle within the trapezoid, with dimensions 6 cm by 4.5 cm, $6 \times 4.5 = 27$.

A student who selects this response may have some understanding of how to decompose a trapezoid into triangles and a rectangle. However, the student did not include the areas of the remaining two triangles in order to find the total area of the given figure.

Answer Choice B: “ 33.8 cm^2 ” This response is incorrect and may occur when the student only calculates the area of the rectangle and one triangle within the trapezoid.

$$6.75 + 27 = 33.75 \approx 33.8$$

A student who selects this response may have some understanding of how to decompose a trapezoid into triangles and a rectangle. However, the student may have only included the triangle “shown” in the image and did not calculate the additional triangle when finding the total area of the given figure.

Answer Choice C: “ 40.5 cm^2 ” The student has correctly solved for the area of the isosceles trapezoid. The quadrilateral may be decomposed into two triangles with identical dimensions and a rectangle. To begin, a student may first subtract 4.5 from 9 to find the dimensions of the base of the two triangles: $9.5 - 4.5 = 4.5$. Since the dimensions of the triangles are the same, the base is half of 4.5: $4.5 \div 2 = 2.25$.

The area of the two triangles could then be calculated.

$$A = 2\left(\frac{1}{2}bh\right)$$

$$A = 2.25 \times 6 = 13.5$$

The student may then find the area of the rectangle.

$$A = lw$$

$$A = 6 \times 4.5 = 27$$

Finally, the last step would be to add the area of the two triangles to the area of the rectangle to find the total area of the trapezoid.

$$13.5 + 27 = 40.5$$

The area of the trapezoid is 40.5 cm².

Answer Choice D: "54 cm²" This response is incorrect and may occur when the student multiplies the base of the trapezoid by the height in order to calculate the total area: $6 \times 9 = 54$. A student who selects this response may not have a conceptual understanding of how to calculate the area of a trapezoid by decomposing it into triangles and a rectangle or may incorrectly apply the formula for calculating the area of a rectangle to a trapezoid.

Answer choices A, B, and D are plausible but incorrect. They are based on conceptual and procedural errors made when a student is finding the area of a trapezoid by decomposing it into triangles and a rectangle in the context of solving the mathematical problem.

The table below shows the number of tea bags needed to make different amounts of iced tea.

Number of Tea Bags	Total Quarts of Iced Tea
8	2
16	4
24	?
36	9

What is the total number of quarts of iced tea that can be made with 24 tea bags?

- A 5
- B 6
- C 7
- D 8

Key: B

Aligned CCLS: 6.RP.3a

Commentary: This item measures 6.RP.3a because it asks students to find the missing value in a table of equivalent ratios relating quantities with whole number measurements.

Extended Rationale

Answer Choice A: "5" This response is incorrect and may occur when a student adds 1 quart to the 4 above it in the table. A student who selects this response may not yet understand how to recognize equivalent ratios or to solve for missing values in a table of equivalent ratios.

Answer Choice B: "6" The student has correctly identified the missing value in the table of equivalent ratios. Students may recognize that the values on the left side of the table (Number of Tea Bags) are divided by 4 to arrive at the values on the right side of the table (Total Quarts of Iced Tea). Students may also recognize that as the number of tea bags increases by eight (from 8 to 16) the total quarts of iced tea rise by two (from 2 to 4) and determine that another increase by eight (from 16 to 24) will lead to an equivalent increase of two in the total quarts of iced tea.

Answer Choice C: "7" This response is incorrect and may occur when a student selects a number that is approximately mid-way between 4 and 9. A student who selects this response may have limited understanding how to interpret a ratio table but lacks precision in solving for missing values in a table of equivalent ratios.

Answer Choice D: "8" This response is incorrect and may occur when a student subtracts 1 quart from the 9 below it in the table. A student who selects this response may not yet recognize equivalent ratios or understand how to use ratios to solve for missing values in a table of equivalent ratios.

Answer options A, C, and D are plausible but incorrect. They are based on conceptual errors made when a student is finding the missing value in a table of equivalent ratios.

A printer makes more than 3 copies of a book every hour. Which graph represents the number of books made in 4 hours?

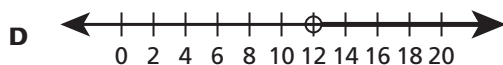
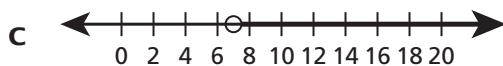
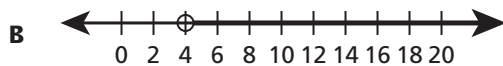
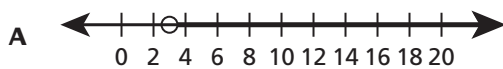

Key: D

Aligned CCLS: 6.EE.8

Commentary: This item measures 6.EE.8 because it requires the student to recognize that inequalities of the form $x > c$ have infinitely many solutions and can be represented on a number line diagram; the inequality also represents a real-world problem.

Extended Rationale

Answer Choice A: This response may occur when the student incorrectly identifies the graph which displays the number of copies of a book that could be printed in one hour. A student may have selected this graph, which represents numbers greater than approximately 3, to represent the rate of “3 copies of a book every hour.” This student may have limited understanding of interpreting inequalities in a real-world problem.

Answer Choice B: This response may occur when the student incorrectly identifies the graph representing numbers greater than 4. The 4 represents the number of hours rather than the number of copies of a book being printed. This student may have limited understanding of interpreting inequalities in a real-world problem.

Answer Choice C: This response is incorrect and may occur when the student incorrectly adds the two numbers in the stem together, rather than multiply. A student who selects this response may have difficulty selecting the relevant operation when solving a real-world problem.

Answer Choice D: The student has identified the correct representation of the inequality on a number line diagram. The student correctly determines that in 4 hours the printer can print more than 12 books ($4 \times 3 = 12$) and selects the number line diagram of the inequality that shows a range of values greater than 12.

Answer options A, B, and C are plausible but incorrect. They are based on conceptual errors made when a student is recognizing that inequalities of the form $x > c$ have infinitely many solutions and can be represented on a number line diagram.

What is the solution to the equation below?

$$4w = \frac{2}{3}$$

A $w = \frac{2}{12}$

B $w = \frac{2}{7}$

C $w = \frac{8}{3}$

D $w = 3\frac{1}{3}$

Key: A

Aligned CCLS: 6.EE.7

Commentary: This item measures 6.EE.7 because it requires the student solve a mathematical problem of the form $px = q$ for cases in which p , q , and x are all nonnegative rational numbers.

Extended Rationale

Answer Choice A: " $w = \frac{2}{12}$ " The student has correctly solved the equation.

The student may have performed the following steps:

$$4w = \frac{2}{3}$$

$$w = \frac{2}{3} \div 4$$

$$w = \frac{2}{3} \times \frac{1}{4} = \frac{2}{12}$$

The student may also have tested each of the answer choices provided to determine which will make the equation true: $4 \times \frac{2}{12} = \frac{8}{12} = \frac{2}{3}$.

Answer Choice B: " $w = \frac{2}{7}$ " This response is incorrect and may occur when a student attempts to solve for x by adding 4 to the right side of the equation and in doing so adds 4 to the denominator of $\frac{2}{3}$.

$$w = \frac{2}{4+3} = \frac{2}{7}$$

A student who selects this response may lack a conceptual understanding of how to solve mathematical problems of the form $px = q$.

Answer Choice C: " $w = \frac{8}{3}$ " This response is incorrect and may occur when a student multiplies $\frac{2}{3}$ by 4, rather than divides by 4 to solve for x .

$$w = \frac{2}{3} \times 4 = \frac{8}{3}$$

A student who selects this response may lack a conceptual understanding of solving mathematical problems of the form $px = q$.

Answer Choice D: " $w = 3\frac{1}{3}$ " This response is incorrect and may occur when a student attempts to solve for x by subtracting 4 from the right side of the equation and by subtracting $\frac{2}{3}$ from 4.

$$w = 4 - \frac{2}{3} = \frac{12}{3} - \frac{2}{3} = \frac{10}{3} = 3\frac{1}{3}$$

A student who selects this response may lack a conceptual understanding of solving mathematical problems of the form $px = q$.

Answer options B, C, and D are plausible but incorrect. They are based on a conceptual understanding of solving a mathematical problem of the form $px = q$ for cases in which p , q , and x are all nonnegative rational numbers.

Which number best represents the location of point E on the number line below?

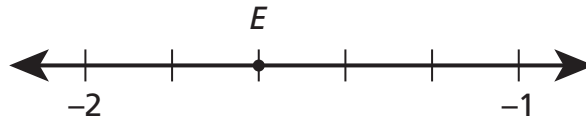

- A** -1.8
- B** -1.6
- C** -1.5
- D** -1.3

Key: B
Aligned CCLS: 6.NS.6c

Commentary: This item measures 6.NS.6c because it requires students to determine the position of a rational number on a horizontal number line diagram.

Extended Rationale

Answer Choice A: “ -1.8 ” This response may indicate a procedural error when determining the position of a rational number on a number line. The student may have used 0.1 as the distance between tick marks and counted from -2 to -1 to determine point E as -1.8 .

Answer Choice B: “ -1.6 ” The student has correctly identified the position of the rational number on the horizontal number line diagram. The student correctly identified each interval on the number line to represent 0.2 .

Answer Choice C: “ -1.5 ” This response is incorrect and may occur when a student estimates or lacks precision when identifying the location of point E .

As a result, the student places the point exactly halfway between -1 and -2 .

Answer Choice D: “ -1.3 ” This response is incorrect and may occur when a student uses 0.1 as the distance between tick marks when counting from -1 to -2 on the number line.

Answer options A, C, and D are plausible but incorrect. They are based on procedural errors made when a student is determining the position of a rational number on a horizontal number line diagram.

Which pair of expressions below is equivalent?

- A** $x + y + x + y$ and $2(x + y)$
- B** $5(2x - 3y)$ and $10x - 3y$
- C** $4x - 5y$ and $5y - 4x$
- D** $9x + 2y$ and $11xy$

Key: A

Aligned CCLS: 6.EE.4

Commentary: This item measures 6.EE.4 because students are required to identify when two expressions are equivalent; equivalent expressions name the same number regardless of which value is substituted into them.

Extended Rationale

Answer Choice A: " $x + y + x + y$ and $2(x + y)$ " The student has correctly identified the equivalent expressions. Students may determine equivalence by combining the like terms in the expression, $x + y + x + y = 2x + 2y$ and rewriting using the distributive property, $2(x + y) = 2x + 2y$. Students may also select different values for x and y and notice that these two expressions remain equal. For example, if $x = 2$ and $y = 3$ the value of $x + y + x + y = 2 + 3 + 2 + 3 = 10$ and the value of $2(x + y) = 2(2 + 3) = 2(5) = 10$. This could be repeated with other values of x and y to informally verify their equivalence. These expressions always name the same number regardless of which values are substituted into them.

Answer Choice B: " $5(2x - 3y)$ and $10x - 3y$ " This response is incorrect and may occur when a student incorrectly applies the distributive property by only multiplying 5 by $2x$ rather than distributing it to both the $2x$ and $-3y$. The student also did not notice that for many substituted values of x and y , these expressions do not name the same number.

Answer Choice C: " $4x - 5y$ and $5y - 4x$ " This response is incorrect and may occur when a student incorrectly assumes that the order of terms in a subtraction expression does not affect the value of the expression (e.g., that subtraction is commutative). The student also did not notice that for many substituted values of x and y , these expressions do not name the same number.

Answer Choice D: " $9x + 2y$ and $11xy$ " This response is incorrect and may occur when a student incorrectly identifies $9x$ and $2y$ as "like terms" and combines them to form $11xy$. A student who selects this response may have a limited understanding of how to perform operations between terms that contain variables. The student also did not notice that for many substituted values of x and y , these expressions do not name the same number.

Answer options B, C, and D are plausible but incorrect. They are based on conceptual errors made when a student is applying properties of operations to generate equivalent expressions.

The coordinates of point A are $(-6, 4)$. The coordinates of point B are $(3, 4)$. Which expression represents the distance, in units, between points A and B ?

A $| -6 | + | 3 |$

B $| 3 | - | -6 |$

C $| -6 | + | -4 |$

D $| 4 | - | -6 |$

Key: A

Aligned CCLS: 6.NS.8

Commentary: This item measures 6.NS.8 because it requires the student to find the distance between two points using absolute value and coordinates located in any of the four quadrants.

Extended Rationale

Answer Choice A: " $| -6 | + | 3 |$ " The student was able to correctly identify the expression which represents the distance, in units, between the two points. In this case, the distance between the points can be found by adding the absolute value of the two x -coordinates. Students may have drawn a sketch of these two coordinates and determined the distance graphically, and then selected the expression that matched the findings from their sketch.

Answer Choice B: " $| 3 | - | -6 |$ " This response is incorrect because the student subtracted the absolute value of the two x -coordinates. A student who selects this response may understand how to determine the distance between two points within one quadrant, but may not yet conceptually understand how to find the distance between two points located in two different quadrants.

Answer Choice C: " $| -6 | + | -4 |$ " This response is incorrect and may occur when the student adds the absolute value of the x -coordinate of the point $(-6, 4)$ to the absolute value of -4 , which may indicate a transcription error of one of the y -coordinates given. A student who selects this response may not yet conceptually understand that because the two points share the same x -value the distance between them is defined by the distance between the two x -values of each point.

Answer Choice D: " $| 4 | - | -6 |$ " This response is incorrect and may occur when the student subtracts the absolute value of the x -coordinate from the y -coordinate of point $(-6, 4)$. A student who selects this response may conceptually understand how to determine the distance between two points if both are located within the first quadrant, but may not yet conceptually understand how to find the distance between two points located in two different quadrants.

Answer options B, C, and D are plausible but incorrect. They are based on conceptual errors made when a student is using coordinates and absolute value to find distances between points.

Which expression represents the phrase below?

8 less than the product of 6 and a number, x

- A** $8 - 6x$
- B** $6x - 8$
- C** $(6 + x) - 8$
- D** $8 - (6 + x)$

Key: B

Aligned CCLS: 6.EE.2a

Commentary: This item measures 6.EE.2a because students must identify expressions that record operations with numbers and with letters standing for numbers.

Extended Rationale

Answer Choice A: " $8 - 6x$ " This response is incorrect and may occur when the student interprets "less than" as "less" or records the operations in the order that they literally appear in the given phrase. A student who selects this response may have difficulty correctly writing expressions, in particular those involving subtraction.

Answer Choice B: " $6x - 8$ " The student has correctly identified the expression that records both the operation of subtraction and multiplication. The student correctly translates the "product of 6 and a number, x " as the operation of multiplications as well as the phrase "8 less than" ("8 subtracted from") to identify the correct expression, $6x - 8$.

Answer Choice C: " $(6 + x) - 8$ " This response is incorrect and may occur when the student interprets "product" as the answer to an addition problem. A student who selects this response may not yet have a firm understanding of the language used to describe mathematical operations in expressions of this type.

Answer Choice D: " $8 - (6 + x)$ " This response is incorrect and may occur when the student interprets "product" as the answer to an addition problem and also interprets "less than" as "less." The student may also be incorrectly recording the operation of subtraction in the order that it literally appears in the given phrase. A student who selects this response may not yet have a firm understanding of the language used to describe and record mathematical operations.

Answer options A, C, and D are plausible but incorrect. They are based on a conceptual understanding of how to write or identify expressions that record operations with numbers and with letters standing for numbers.

Point G is the point $(3, -1)$.

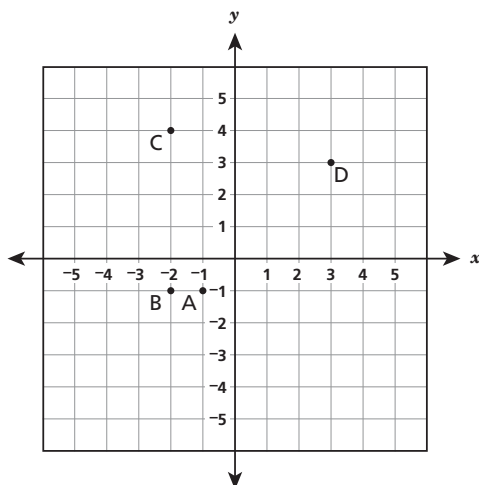

Which point is 5 units from point G?

- A point A
- B point B
- C point C
- D point D

Key: B

Aligned CCLS: 6.NS.8

Commentary: This item measures 6.NS.8 because it requires the student to graph a point on the coordinate plane and to find distances between points, using coordinates and possibly absolute value.

Extended Rationale

Answer Choice A: "point A" This response is incorrect and may occur when the student does not count the number of units between the points in coordinate plane; a common error is when the student counts the number of lines, rather than intervals between lines. A student who selects this response may not yet understand how to use the coordinate plane to find the distance between two points.

Answer Choice B: "point B" The student was able to correctly graph the point $(3, -1)$ and determine that point B is 5 units from point G. The student may have used the graph to count the number of units between point B and point G. The student may also have added the absolute values of the x-coordinates of point B, located at $(-2, -1)$ and point G: $|3| + |-2| = 5$.

Answer Choice C: "point C" This response is incorrect and may occur when the student counts 5 units up and 5 units to the left of Point G. A student who selects this response may not yet understand that the distance between two points on the coordinate plane is the straight line distance between two points.

Answer Choice D: "point D" This response is incorrect and may occur when the student does not count the number of units between the points in coordinate plane; a common error is when the student counts the number of lines, rather than intervals between lines. A student who selects this response may not yet understand how to find the distance between two points on a coordinate plane.

Answer options A, C, and D are plausible but incorrect. They are based on conceptual errors made when a student is using coordinates and absolute value to find distances between points on a coordinate plane.

In the diagram of a quadrilateral below, the variables represent the lengths of the sides, in inches.

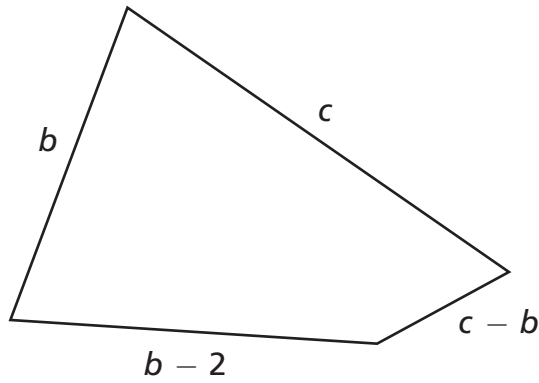

[not drawn to scale]

Write an expression using the variables b and c that could be used to find the perimeter of the quadrilateral.

Answer _____

If $b = 11$ and $c = 16$, what is the perimeter of the quadrilateral?

Show your work.

Answer _____ inches

Measured CCLS: 6.EE.6

Commentary: The item measures 6.EE.6 because a student is required to use variables to represent numbers and write an expression to solve a mathematical problem. The student must understand that a variable can represent an unknown number.

Extended Rationale: As indicated in the rubric, student responses will be rated on whether the student demonstrates a thorough understanding of the mathematics concepts and procedures embodied in the task. The response should contain an appropriate solution to all parts of the task using mathematically sound procedures.

The correct answer may be arrived at by adding all of the side lengths together to determine the perimeter of the figure.

The expression $b + b - 2 + c + c - b$ represents the perimeter, which can be simplified as $b - 2 + 2c$.

The second part of the problem requires students to substitute in values for the variables in the perimeter of the figure.

$$b - 2 + 2c$$

$$(11) - 2 + 2(16) = 9 + 32 = 41$$

The student would then determine that the perimeter of the quadrilateral is 41 inches.

Substituting 11 and 16 into the equivalent, unsimplified expression $b + b - 2 + c + c - b$ will name the same number:

$$(11) + (11) - 2 + (16) + (16) - 11 = 41$$

SAMPLE STUDENT RESPONSES AND SCORES APPEAR ON THE FOLLOWING PAGES:

In the diagram of a quadrilateral below, the variables represent the lengths of the sides, in inches.

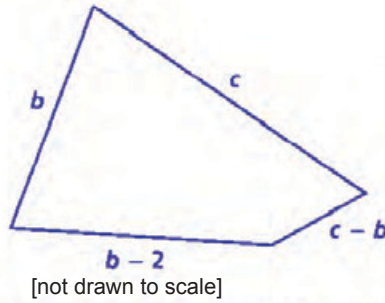

$$c + b + b - 2 + c - b$$

$$c + 2b - 2 + c - b$$

$$2c + 2b - 2 - b$$

$$\boxed{2c + b - 2}$$

Write an expression using the variables b and c that could be used to find the perimeter of the quadrilateral.

Answer $2c + b - 2$

If $b = 11$ and $c = 16$, what is the perimeter of the quadrilateral?

Show your work.

$$2c + b - 2$$

$$2(16) + 11 - 2$$

$$2 \cdot 16 = 32$$

Permdas

$$32 + 11 - 2 = 43 - 2 = \boxed{41}$$

Answer 41 inches

Score Point 2 (out of 2 points)

This response answers the questions correctly and demonstrates a thorough understanding of the mathematical concepts. The first answer ($2c + b - 2$) is correct. The work shown ($2(16) + 11 - 2$) demonstrates a correct procedure for determining the second answer (41).

In the diagram of a quadrilateral below, the variables represent the lengths of the sides, in inches.

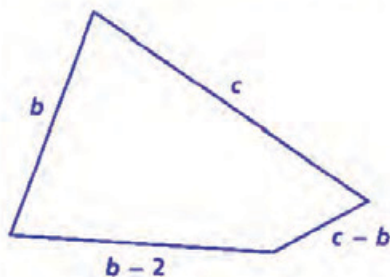

[not drawn to scale]

Write an expression using the variables b and c that could be used to find the perimeter of the quadrilateral.

Answer $2b - 2 + 2c - b$

If $b = 11$ and $c = 16$, what is the perimeter of the quadrilateral?

Show your work.

$$\begin{array}{r} 11 \\ 16 \\ 9 \\ + 5 \\ \hline 41 \end{array} \quad \begin{array}{r} b=11 \\ c=16 \\ b-2=9 \\ c-b=5 \\ \hline 41 \end{array}$$

Answer 41 inches

Score Point 2 (out of 2 points)

This response indicates that the student has completed the task correctly, using mathematically sound procedures. The first answer ($2b - 2 + 2c - b$) is correct. The work shown ($11 + 16 + 9 + 5$) demonstrates a correct procedure for determining the second answer.

In the diagram of a quadrilateral below, the variables represent the lengths of the sides, in inches.

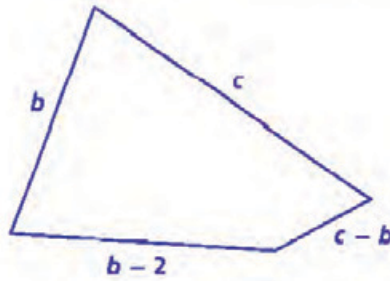

[not drawn to scale]

Write an expression using the variables b and c that could be used to find the perimeter of the quadrilateral.

Answer $b + c + b - 2 + c - b = P$

If $b = 11$ and $c = 16$, what is the perimeter of the quadrilateral?

Show your work.

$$\begin{aligned} b + c &= 11 + 16 = 27 \\ b - 2 &= 11 - 2 = 9 \\ c - b &= 16 - 11 = 5 \end{aligned}$$
$$\begin{array}{r} 27 \\ + 9 \\ \hline 36 \end{array}$$
$$\begin{array}{r} 36 \\ + 5 \\ \hline 41 \end{array}$$

Answer 41 inches

Score Point 2 (out of 2 points)

This response answers the questions correctly and demonstrates a thorough understanding of the mathematical concepts. The first answer ($b + c + b - 2 + c - b = p$) is correct. Writing the expression as part of an equation for perimeter does not detract from the demonstration of a thorough understanding. The work shown demonstrates a correct procedure for determining the second answer.

In the diagram of a quadrilateral below, the variables represent the lengths of the sides, in inches.

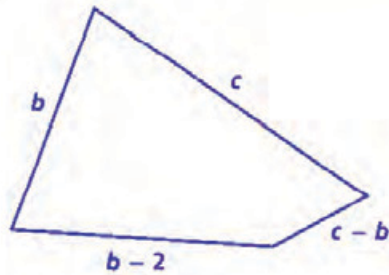

[not drawn to scale]

Write an expression using the variables b and c that could be used to find the perimeter of the quadrilateral.

Answer $b - 2 + c - b + c + b$ $b - 2 + c - b + c + b$

If $b = 11$ and $c = 16$, what is the perimeter of the quadrilateral?

Show your work.

$$\begin{array}{r} 11 \\ \times 2 \\ \hline 22 \end{array} \quad \begin{array}{r} 16 \\ \times 2 \\ \hline 32 \end{array} \quad \begin{array}{r} 32 \\ + 22 \\ \hline 54 \end{array}$$

Answer 54 inches

Score Point 1 (out of 2 points)

This response demonstrates only a partial understanding of the mathematical concepts embodied in the task. The first answer ($b - 2 + c - b + c + b$) is correct. The work shown does not demonstrate a correct procedure for determining the perimeter and the second answer is incorrect.

In the diagram of a quadrilateral below, the variables represent the lengths of the sides, in inches.

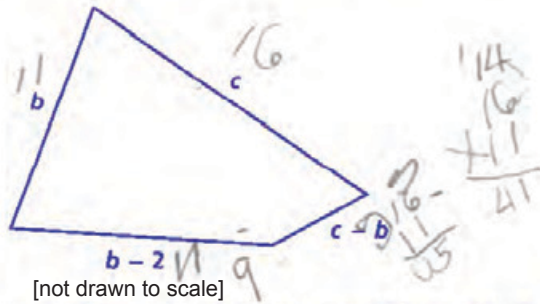

Write an expression using the variables b and c that could be used to find the perimeter of the quadrilateral.

Answer ~~$b - 2 + 16$~~

If $b = 11$ and $c = 16$, what is the perimeter of the quadrilateral?

Show your work.



Answer 41 inches

Score Point 1 (out of 2 points)

This response demonstrates only a partial understanding of the mathematical concepts. The first answer is incorrect. The work shown in the designated “Show your work” area for the second part of the problem demonstrates an incorrect procedure ($16 + 5 + 9 + 16 + 11$) for determining the perimeter. However, the work shown on the illustration ($14 + 16 + 11 = 41$) is correct and the second answer is also correct.

Additional

In the diagram of a quadrilateral below, the variables represent the lengths of the sides, in inches.

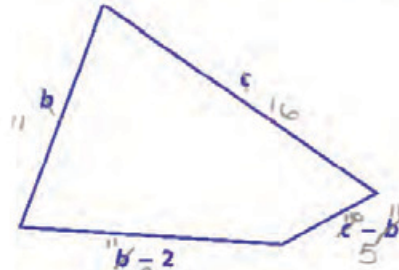

[not drawn to scale]

Write an expression using the variables b and c that could be used to find the perimeter of the quadrilateral.

Answer 41

If $b = 11$ and $c = 16$, what is the perimeter of the quadrilateral?

Show your work.

$$\begin{array}{r} 2 \\ 11 \\ + 16 \\ + 5 \\ + 9 \\ \hline 41 \end{array}$$

Answer 41 inches

Score Point 1 (out of 2 points)

This response correctly addresses some elements of the task. The first answer is incorrect. The work shown $(11 + 16 + 5 + 9)$ demonstrates a correct procedure for determining the perimeter and the second answer is correct.

In the diagram of a quadrilateral below, the variables represent the lengths of the sides, in inches.

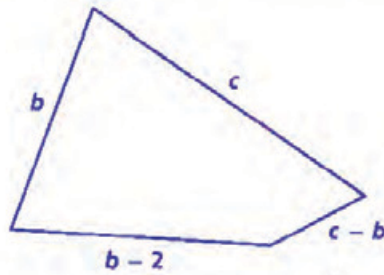

[not drawn to scale]

Write an expression using the variables b and c that could be used to find the perimeter of the quadrilateral.

Answer $b - 2 - c - b$
 $11 - 2 - 16$

If $b = 11$ and $c = 16$, what is the perimeter of the quadrilateral?

Show your work.

$11 - 2 - 16$
 $9 - 16$
 $\textcircled{7}$

$\frac{16}{7}$

Answer 7 inches

Score Point 0 (out of 2 points)

This response is incorrect. The first answer is incorrect. The work shown does not demonstrate an appropriate procedure for determining the perimeter and the second answer is incorrect.

In the diagram of a quadrilateral below, the variables represent the lengths of the sides, in inches.

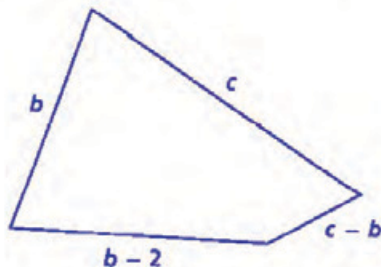

[not drawn to scale]

Write an expression using the variables b and c that could be used to find the perimeter of the quadrilateral.

Answer $b - 2 + c - b$

If $b = 11$ and $c = 16$, what is the perimeter of the quadrilateral?

Show your work.

Handwritten work showing a sequence of calculations:

$$\begin{array}{r}
 11 \cdot 16 \cdot 11 - 2 \cdot 16 \cdot 11 \\
 \hline
 27 \cdot 11 - 2 \cdot 16 \cdot 11 \\
 \hline
 847 - 2 \cdot 16 \cdot 11 \\
 \hline
 847 - 2 \cdot 77 \\
 \hline
 845 \cdot 77 \\
 \hline
 \boxed{11,869}
 \end{array}$$

Handwritten multiplication work:

$$\begin{array}{r}
 77 \\
 \times 11 \\
 \hline
 177 \\
 + 770 \\
 \hline
 847 \\
 \hline
 333 \\
 849 \\
 \hline
 77 \\
 \hline
 849 \\
 + 8490 \\
 \hline
 1,1865
 \end{array}$$

Answer 11,869 inches

Score Point 0 (out of 2 points)

This response is incorrect. The first answer is incorrect. The work shown does not demonstrate an appropriate procedure to determine the perimeter and the second answer is incorrect.

The area of a rectangular park is $\frac{3}{5}$ square mile. The length of the park is $\frac{7}{8}$ mile. What is the width of the park?

Show your work.

Answer _____ mile

Measured CCLS: 6.NS.1

Commentary: This item measures 6.NS.1 because it requires the student to solve a word problem involving division of a fraction by a fraction.

Extended Rationale: As indicated in the rubric, student responses will be rated on whether the student provides evidence of a strong understanding of solving word problems involving division of fractions by fractions. The response should contain an appropriate solution and supporting evidence consistent with the solution given.

The correct answer may be arrived at by recognizing that the area of the park can be found using the formula for the area of a rectangle, $A = l \times w$. Given this relationship, the student determines that the area of the park needs to be divided by the given length of the park in order to determine the width.

$$\frac{3}{5} \div \frac{7}{8} = \frac{3}{5} \times \frac{8}{7} = \frac{24}{35}$$

The width of the park is $\frac{24}{35}$ mile.

SAMPLE STUDENT RESPONSES AND SCORES APPEAR ON THE FOLLOWING PAGES:

Additional

The area of a rectangular park is $\frac{3}{5}$ square mile. The length of the park is $\frac{7}{8}$ mile. What is the width of the park?

Show your work.

$$A = lw$$
$$\frac{3}{5} = \frac{7}{8} x$$
$$\cdot 8 \quad \cancel{\times 8}$$
$$\frac{24}{5}$$

$$\frac{24}{5} = \frac{7}{8} x$$

$$x = \frac{24}{35}$$

$$\frac{3}{5} \cdot \frac{8}{1} = \frac{24}{5}$$

$$\frac{24}{5} \div \frac{7}{1} \rightarrow \frac{24}{5} \cdot \frac{1}{7} = \frac{24}{35}$$

check

$$A = lw$$

$$\frac{3}{5} \stackrel{?}{=} \frac{7}{8} \cdot \frac{24}{35} = \frac{3}{5}$$

$$\frac{3}{5} = \frac{3}{5} \checkmark$$

$\frac{24}{35}$ mile is the width of the park.

Answer: $\frac{24}{35}$ mile

Score Point 2 (out of 2 points)

This response demonstrates a thorough understanding of the mathematical concepts embodied in the task. The answer ($\frac{24}{35}$) is correct and the work shown ($\frac{3}{5} = \frac{7}{8} x$; $\frac{3}{5} \times 8 = \frac{7}{8} \times 8$; $\frac{24}{5} \div 7 = 7x \div 7$; $x = \frac{24}{35}$) is a mathematically sound procedure.

The area of a rectangular park is $\frac{3}{5}$ square mile. The length of the park is $\frac{7}{8}$ mile. What is the width of the park?

Show your work.

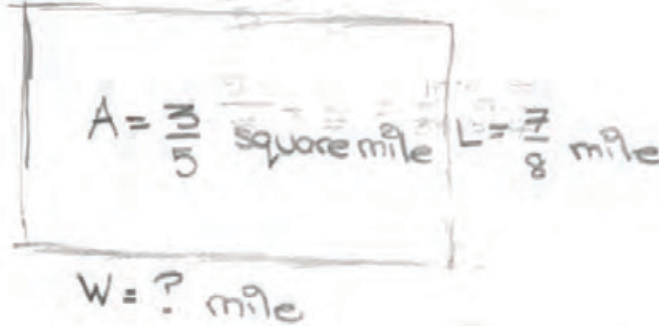

$$\frac{3}{5} \times \frac{24}{35} = \frac{168}{175} \div 2 = \frac{84}{87.5}$$

$$\frac{24}{7} = \frac{168}{49}$$

$$\frac{35}{8} = \frac{175}{64}$$

$$\frac{3}{5} \times \frac{24}{35} = \frac{72}{175}$$

Answer, $\frac{24}{35}$ mile

Score Point 2 (out of 2 points)

This response demonstrates a thorough understanding of the mathematical concepts embodied in the task. The answer ($\frac{24}{35}$) is correct and the work shown ($\frac{3}{5} \div \frac{7}{8}$, $\frac{3}{5} \times \frac{8}{7} = \frac{24}{35}$) is a mathematically sound procedure.

The area of a rectangular park is $\frac{3}{5}$ square mile. The length of the park is $\frac{7}{8}$ mile. What is the width of the park?

Show your work.

$$\begin{array}{r} \frac{3}{5} \text{ mi}^2 \\ \times \frac{8}{7} \\ \hline \frac{24}{35} \end{array}$$

Check
add work
at =

Answer $\frac{24}{35}$ mile

Score Point 2 (out of 2 points)

This response demonstrates a thorough understanding of the mathematical concepts embodied in the task. The answer ($\frac{24}{35}$) is correct and the work shown ($\frac{3}{5} \div \frac{7}{8}$, $\frac{3}{5} \times \frac{8}{7} = \frac{24}{35}$) is procedurally correct.

The area of a rectangular park is $\frac{3}{5}$ square mile. The length of the park is $\frac{7}{8}$ mile. What is the width of the park?

Show your work.

$$\frac{3}{5} \div \frac{7}{8}$$

$$\frac{3}{5} \times \frac{8}{7} = \frac{24}{35}$$

$$\frac{3}{5} \times \frac{8}{7} = \frac{24}{35}$$

$$\frac{3}{5} \times \frac{8}{7} = \frac{24}{35}$$

$$\frac{3}{5} \times \frac{8}{7} = \frac{24}{35}$$

Answer: $\frac{5}{3}$ mile

Score Point 1 (out of 2 points)

This response demonstrates only a partial understanding of the mathematical concepts embodied in the task. The answer ($\frac{5}{3}$) is incorrect; however, the work shows ($\frac{3}{5} \div \frac{7}{8}$, $\frac{3}{5} \times \frac{8}{7} = \frac{24}{35}$) a sound procedure for the calculation of the width. The response errs in the simplification process, resulting in an incorrect answer.

The area of a rectangular park is $\frac{3}{5}$ square mile. The length of the park is $\frac{7}{8}$ mile. What is the width of the park?

Show your work.

$$\frac{7}{8} \div \frac{3}{5}$$

↓

$$\frac{7}{8} \cdot \frac{5}{3} = \frac{35}{24}$$

~~$\frac{7}{8} \div \frac{3}{5} = \frac{35}{24}$~~

Answer. $\frac{35}{24}$ mile

Score Point 1 (out of 2 points)

This response demonstrates only a partial understanding of the mathematical concepts. The work shown divides length by area ($\frac{7}{8} \div \frac{3}{5}$) instead of dividing area by length. However, the division of fractions is completed correctly ($\frac{7}{8} \div \frac{3}{5}; \frac{7}{8} \times \frac{5}{3} = \frac{35}{24}$).

Additional

The area of a rectangular park is $\frac{3}{5}$ square mile. The length of the park is $\frac{7}{8}$ mile. What is the width of the park?

$$A = lW$$

Show your work.

$$\frac{3}{5} = \frac{7}{8} \times W$$

$$A = lW$$

$$\frac{3}{5} = \frac{7}{8} \times W$$

$$\frac{3}{5} \times \frac{8}{7} = \frac{21}{40}$$

$$A = lW$$
$$A = \frac{7}{8} \times \frac{21}{40}$$
$$A =$$

$$\frac{7 \times 5}{8 \times 5} = \frac{35}{40}$$
$$\frac{21}{40} = \frac{21}{40}$$

$$\frac{14}{40} = \frac{7 \times 5}{20 \times 5} = \frac{35}{100}$$
$$\frac{35}{40} = \frac{21}{14}$$

Answer $\frac{35}{100}$ mile

Score Point 0 (out of 2 points)

This response is incorrect. The fractions are correctly substituted into the area formula; however, the remaining work and the answer are incorrect. Although the substitution is correct, this alone is not sufficient to demonstrate even a limited understanding of the mathematical concepts.

Jodi's car used 12 gallons of gas to travel 456 miles. How many miles did her car travel per gallon of gas?

Show your work.

Answer _____ miles per gallon

It cost Jodi \$44.88 to buy 12 gallons of gas. What was the cost per gallon of gas?

Show your work.

Answer \$ _____

Measured CCLS: 6.RP.2; 6.RP.3b

Commentary: The item measures 6.RP.2 and 6.RP.3b because it requires students to understand the concept of a unit rate, interpret rate language in the context of a ratio relationship, and solve unit rate problems.

Extended Rationale: As indicated in the rubric, student responses will be rated on whether the student provides evidence of a strong understanding of determining the unit rates in the problem. The response should contain an appropriate solution to all parts of the task and supporting evidence consistent with the solutions given.

In the first part of the problem, the correct answer may be arrived at by recognizing that the quantities of gas and distance have a proportional relationship. Understanding this is often facilitated through a ratio table:

Miles traveled	?	456
Gallons of gas	1	12

Determining the unit rate, the number of miles traveled per gallon, involves dividing the number of miles traveled, 456 by 12: $456 \div 12 = 38$.

The student would then determine that Jodie’s car travels 38 miles on 1 gallon of gas.

Alternatively, a student could guess different values to multiply by 12 in order to get 456, eventually arriving at 38.

Similarly, the second part of the problem requires recognizing that the quantities of gas and price are also in a proportional relationship. To determine the unit rate, or price per gallon, divide 44.88 by 12 to get \$3.74 per gallon.

While guessing and checking could be time-consuming in this part, a student could also guess different values to multiply by 12 to get 44.88, eventually arriving at 3.74.

SAMPLE STUDENT RESPONSES AND SCORES APPEAR ON THE FOLLOWING PAGES:

Jodi's car used 12 gallons of gas to travel 456 miles. How many miles did her car travel per gallon of gas?

Show your work.

$$\begin{array}{r} 38 \text{ per mile} \\ 12 \overline{) 456} \\ \underline{36} \\ 096 \\ \underline{096} \\ 0 \end{array} \quad \begin{array}{r} 12 \\ \times 3 \\ \hline 36 \end{array} \quad \begin{array}{r} 1 \\ 12 \\ \times 8 \\ \hline 96 \end{array}$$

Answer: 38 miles per gallon

It cost Jodi \$44.88 to buy 12 gallons of gas. What was the cost per gallon of gas?

Show your work.

$$\begin{array}{r} 3.74 \\ 12.00 \overline{) 44.88} \\ \underline{36.00} \\ 08.880 \\ \underline{08.400} \\ 0.480 \\ \underline{0.480} \\ 0 \end{array} \quad \begin{array}{r} 1 \\ 12 \\ \times 7 \\ \hline 84 \end{array} \quad \begin{array}{r} 12 \\ \times 4 \\ \hline 48 \end{array}$$

Answer: \$ 3.74

Score Point 3 (out of 3 points)

This response answers the questions correctly and demonstrates a thorough understanding of the mathematical concepts. This response correctly solves the first part of the problem using $456 \div 12 = 38$ miles per gallon. The response also correctly solves the second part of the problem by showing $\$44.88 \div 12 = \3.74 .

Jodi's car used 12 gallons of gas to travel 456 miles. How many miles did her car travel per gallon of gas?

Show your work.

$$\begin{array}{r}
 \times 38 \\
 12 \overline{) 456} \\
 \underline{-36} \\
 96 \\
 \underline{-96} \\
 0
 \end{array}$$

$$\begin{array}{r}
 12 \\
 \times 38 \\
 \hline
 96 \\
 360 \\
 \hline
 456
 \end{array}$$

Answer: 38 miles per gallon

It cost Jodi \$44.88 to buy 12 gallons of gas. What was the cost per gallon of gas?

Show your work.

$$\begin{array}{r}
 3.74 \\
 12 \overline{) 44.88} \\
 \underline{-36} \\
 88 \\
 \underline{-84} \\
 48 \\
 \underline{-48} \\
 00
 \end{array}$$

check

$$\begin{array}{r}
 \$ 3.74 \\
 \times 12 \\
 \hline
 748 \\
 3740 \\
 \hline
 44.88 \checkmark
 \end{array}$$

Answer: 3.74

Score Point 3 (out of 3 points)

This response indicates that the student has completed the task correctly, using mathematically sound procedures. This response correctly solves the first part of the problem ($456 \div 12 = 38$) and the second part of the problem ($\$44.88 \div 12 = \3.74) using mathematically sound procedures.

Additional

Jodi's car used 12 gallons of gas to travel 456 miles. How many miles did her car travel per gallon of gas?

Show your work.

$$\begin{array}{r} 38 \\ 12 \overline{) 456} \\ \underline{36} \\ 96 \\ \underline{96} \\ 0 \end{array}$$

Answer. 38 miles per gallon

It cost Jodi \$44.88 to buy 12 gallons of gas. What was the cost per gallon of gas?

Show your work.

$$\begin{array}{r} 3.74 \\ 12 \overline{) 44.88} \\ \underline{36} \\ 88 \\ \underline{84} \\ 48 \\ \underline{48} \\ 0 \end{array}$$

Answer \$ 3.74

Score Point 3 (out of 3 points)

This response answers the questions correctly and demonstrates a thorough understanding of the mathematical concepts. This response correctly solves the first part of the problem ($456 \div 12 = 38$) and the second part of the problem ($\$44.88 \div 12 = \3.74) using mathematically sound procedures.

Jodi's car used 12 gallons of gas to travel 456 miles. How many miles did her car travel per gallon of gas?

Show your work.

$$\begin{array}{r} 40.6 \\ 12 \overline{) 456} \\ \underline{-48} \\ 006 \end{array}$$

Answer: 40.6 miles per gallon

It cost Jodi \$44.88 to buy 12 gallons of gas. What was the cost per gallon of gas?

Show your work.

$$\begin{array}{r} 3.74 \\ 12 \overline{) 44.88} \\ \underline{-36} \\ 088 \\ \underline{-84} \\ 048 \\ \underline{-45} \end{array}$$

$$\begin{array}{r} 12 \cdot 12 \\ \times 8 \quad \times 7 \\ \hline 96 \quad 84 \end{array}$$

Answer: \$3.74

Score Point 2 (out of 3 points)

This response is only partially correct. This response uses a correct procedure to determine the first answer; however, a calculation error results in an incorrect answer (40.6). The second part of the problem contains a correct answer (\$3.74) and appropriate work is shown.

Jodi's car used 12 gallons of gas to travel 456 miles. How many miles did her car travel per gallon of gas?

Show your work.

$$\begin{array}{r} \times 38 \\ 12 \overline{) 456} \\ \underline{36} \\ 96 \\ \underline{96} \\ 0 \end{array}$$

$$\begin{array}{r} 1 \\ 48 \\ \underline{48} \\ 0 \end{array}$$

Answer: 38 miles per gallon

It cost Jodi \$44.88 to buy 12 gallons of gas. What was the cost per gallon of gas?

Show your work.

$$\begin{array}{r} \times 3.07 \\ 12 \overline{) 44.88} \\ \underline{36} \\ 8.88 \\ \underline{8.40} \\ .48 \end{array}$$

$$\begin{array}{r} 1 \\ 45 \\ \underline{+ 30} \\ 84 \end{array}$$

Answer: 3.07

Score Point 2 (out of 3 points)

This response addresses most aspects of the task using mathematically sound procedures. The first part of the problem contains a correct answer and appropriate required work is shown. The work shown for the second answer is procedurally correct; however, a calculation error results in an incorrect answer (\$3.07).

Jodi's car used 12 gallons of gas to travel 456 miles. How many miles did her car travel per gallon of gas?

Show your work.

$$\begin{array}{r} 12 \\ \times 38 \\ \hline 96 \\ 360 \\ \hline 456 \end{array}$$

Answer. 38 miles per gallon

It cost Jodi \$44.88 to buy 12 gallons of gas. What was the cost per gallon of gas?

Show your work.

$$\begin{array}{r} 44.88 \\ \times 12.00 \\ \hline 00000 \\ 00000 \\ 89760 \\ 144980 \\ \hline 1346.40 \end{array}$$

Answer S 1,346.40

Score Point 1 (out of 3 points)

This response demonstrates only a limited understanding of the mathematical concepts embodied in the task. This response correctly identifies the first answer using a correct procedure. The work shown for the second answer ($\$44.88 \times \$12.00 = \$1,346.40$) is procedurally incorrect and results in an incorrect answer.

Jodi's car used 12 gallons of gas to travel 456 miles. How many miles did her car travel per gallon of gas?

Show your work.

$$\frac{12}{456} = 2$$

$$= \frac{6}{228} = 2$$

$$= \frac{3}{114}$$

$$= \frac{0.02}{1111} = \frac{3.00}{1111} = 0.02$$

$$\frac{228}{114} = 2$$

$$\frac{114}{57} = 2$$

$$\frac{57}{28.5} = 2$$

$$\frac{28.5}{14.25} = 2$$

$$\frac{14.25}{7.125} = 2$$

$$\frac{7.125}{3.5625} = 2$$

$$\frac{3.5625}{1.78125} = 2$$

$$\frac{1.78125}{0.890625} = 2$$

$$\frac{0.890625}{0.4453125} = 2$$

$$\frac{0.4453125}{0.22265625} = 2$$

$$\frac{0.22265625}{0.111328125} = 2$$

$$\frac{0.111328125}{0.0556640625} = 2$$

$$\frac{0.0556640625}{0.02783203125} = 2$$

$$\frac{0.02783203125}{0.013916015625} = 2$$

$$\frac{0.013916015625}{0.0069580078125} = 2$$

$$\frac{0.0069580078125}{0.00347900390625} = 2$$

$$\frac{0.00347900390625}{0.001739501953125} = 2$$

$$\frac{0.001739501953125}{0.0008697509765625} = 2$$

$$\frac{0.0008697509765625}{0.00043487548828125} = 2$$

$$\frac{0.00043487548828125}{0.000217437744140625} = 2$$

$$\frac{0.000217437744140625}{0.0001087188720703125} = 2$$

$$\frac{0.0001087188720703125}{5.435943603515625 \times 10^{-5}} = 2$$

$$\frac{5.435943603515625 \times 10^{-5}}{2.7179718017578125 \times 10^{-5}} = 2$$

$$\frac{2.7179718017578125 \times 10^{-5}}{1.35898590087890625 \times 10^{-5}} = 2$$

$$\frac{1.35898590087890625 \times 10^{-5}}{6.79492950439453125 \times 10^{-6}} = 2$$

$$\frac{6.79492950439453125 \times 10^{-6}}{3.397464752197265625 \times 10^{-6}} = 2$$

$$\frac{3.397464752197265625 \times 10^{-6}}{1.6987323760986328125 \times 10^{-6}} = 2$$

$$\frac{1.6987323760986328125 \times 10^{-6}}{8.4936618804931640625 \times 10^{-7}} = 2$$

$$\frac{8.4936618804931640625 \times 10^{-7}}{4.24683094024658203125 \times 10^{-7}} = 2$$

$$\frac{4.24683094024658203125 \times 10^{-7}}{2.123415470123291015625 \times 10^{-7}} = 2$$

$$\frac{2.123415470123291015625 \times 10^{-7}}{1.0617077350616455078125 \times 10^{-7}} = 2$$

$$\frac{1.0617077350616455078125 \times 10^{-7}}{5.3085386753082275390625 \times 10^{-8}} = 2$$

$$\frac{5.3085386753082275390625 \times 10^{-8}}{2.65426933765411376953125 \times 10^{-8}} = 2$$

$$\frac{2.65426933765411376953125 \times 10^{-8}}{1.327134668827056884765625 \times 10^{-8}} = 2$$

$$\frac{1.327134668827056884765625 \times 10^{-8}}{6.635673344135284423828125 \times 10^{-9}} = 2$$

$$\frac{6.635673344135284423828125 \times 10^{-9}}{3.3178366720676422119140625 \times 10^{-9}} = 2$$

$$\frac{3.3178366720676422119140625 \times 10^{-9}}{1.65891833603382110595703125 \times 10^{-9}} = 2$$

$$\frac{1.65891833603382110595703125 \times 10^{-9}}{8.29459168016910552978515625 \times 10^{-10}} = 2$$

$$\frac{8.29459168016910552978515625 \times 10^{-10}}{4.147295840084552764892578125 \times 10^{-10}} = 2$$

$$\frac{4.147295840084552764892578125 \times 10^{-10}}{2.0736479200422763824462890625 \times 10^{-10}} = 2$$

$$\frac{2.0736479200422763824462890625 \times 10^{-10}}{1.03682396002113819122314453125 \times 10^{-10}} = 2$$

$$\frac{1.03682396002113819122314453125 \times 10^{-10}}{5.18411980010569095611572265625 \times 10^{-11}} = 2$$

$$\frac{5.18411980010569095611572265625 \times 10^{-11}}{2.592059900052845478057861328125 \times 10^{-11}} = 2$$

$$\frac{2.592059900052845478057861328125 \times 10^{-11}}{1.2960299500264227390289306640625 \times 10^{-11}} = 2$$

$$\frac{1.2960299500264227390289306640625 \times 10^{-11}}{6.4801497501321136951446533203125 \times 10^{-12}} = 2$$

$$\frac{6.4801497501321136951446533203125 \times 10^{-12}}{3.24007487506605684757232666015625 \times 10^{-12}} = 2$$

$$\frac{3.24007487506605684757232666015625 \times 10^{-12}}{1.620037437533028423786163330078125 \times 10^{-12}} = 2$$

$$\frac{1.620037437533028423786163330078125 \times 10^{-12}}{8.100187187665142118930816650390625 \times 10^{-13}} = 2$$

$$\frac{8.100187187665142118930816650390625 \times 10^{-13}}{4.0500935938325710594654083251953125 \times 10^{-13}} = 2$$

$$\frac{4.0500935938325710594654083251953125 \times 10^{-13}}{2.02504679691628552973270416259765625 \times 10^{-13}} = 2$$

$$\frac{2.02504679691628552973270416259765625 \times 10^{-13}}{1.012523398458142764866352081298828125 \times 10^{-13}} = 2$$

$$\frac{1.012523398458142764866352081298828125 \times 10^{-13}}{5.062616992290713824331760406494140625 \times 10^{-14}} = 2$$

$$\frac{5.062616992290713824331760406494140625 \times 10^{-14}}{2.5313084961453569121658802032470703125 \times 10^{-14}} = 2$$

$$\frac{2.5313084961453569121658802032470703125 \times 10^{-14}}{1.26565424807267845608294010162353515625 \times 10^{-14}} = 2$$

$$\frac{1.26565424807267845608294010162353515625 \times 10^{-14}}{6.32827124036339228041470050811767578125 \times 10^{-15}} = 2$$

$$\frac{6.32827124036339228041470050811767578125 \times 10^{-15}}{3.164135620181696140207350254058837890625 \times 10^{-15}} = 2$$

$$\frac{3.164135620181696140207350254058837890625 \times 10^{-15}}{1.5820678100908480701036751270294189453125 \times 10^{-15}} = 2$$

$$\frac{1.5820678100908480701036751270294189453125 \times 10^{-15}}{7.9103390504542403505183756351470947265625 \times 10^{-16}} = 2$$

$$\frac{7.9103390504542403505183756351470947265625 \times 10^{-16}}{3.95516952522712017525918781757354736328125 \times 10^{-16}} = 2$$

$$\frac{3.95516952522712017525918781757354736328125 \times 10^{-16}}{1.977584762613560087629593908786773681640625 \times 10^{-16}} = 2$$

$$\frac{1.977584762613560087629593908786773681640625 \times 10^{-16}}{9.887923813067800438147969543933868408203125 \times 10^{-17}} = 2$$

$$\frac{9.887923813067800438147969543933868408203125 \times 10^{-17}}{4.9439619065339002190739847719669342041015625 \times 10^{-17}} = 2$$

$$\frac{4.9439619065339002190739847719669342041015625 \times 10^{-17}}{2.47198095326695010953699238598346710205078125 \times 10^{-17}} = 2$$

$$\frac{2.47198095326695010953699238598346710205078125 \times 10^{-17}}{1.235990476633475054768496192991733551025390625 \times 10^{-17}} = 2$$

$$\frac{1.235990476633475054768496192991733551025390625 \times 10^{-17}}{6.179952383167375273842480964958667755126953125 \times 10^{-18}} = 2$$

$$\frac{6.179952383167375273842480964958667755126953125 \times 10^{-18}}{3.0899761915836876369212404824793338775634765625 \times 10^{-18}} = 2$$

$$\frac{3.0899761915836876369212404824793338775634765625 \times 10^{-18}}{1.54498809579184381846062024123966693878173828125 \times 10^{-18}} = 2$$

$$\frac{1.54498809579184381846062024123966693878173828125 \times 10^{-18}}{7.72494047895921909230310120619833469390869140625 \times 10^{-19}} = 2$$

$$\frac{7.72494047895921909230310120619833469390869140625 \times 10^{-19}}{3.862470239479609546151550603099167346954345703125 \times 10^{-19}} = 2$$

$$\frac{3.862470239479609546151550603099167346954345703125 \times 10^{-19}}{1.9312351197398047730757753015495836734771728515625 \times 10^{-19}} = 2$$

$$\frac{1.9312351197398047730757753015495836734771728515625 \times 10^{-19}}{9.6561755986990238653788765077479183673858642578125 \times 10^{-20}} = 2$$

$$\frac{9.6561755986990238653788765077479183673858642578125 \times 10^{-20}}{4.82808779934951193268943825387395918369293212890625 \times 10^{-20}} = 2$$

$$\frac{4.82808779934951193268943825387395918369293212890625 \times 10^{-20}}{2.414043899674755966344719126936979591846466064453125 \times 10^{-20}} = 2$$

$$\frac{2.414043899674755966344719126936979591846466064453125 \times 10^{-20}}{1.2070219498373779831723595634684897959232330322265625 \times 10^{-20}} = 2$$

$$\frac{1.2070219498373779831723595634684897959232330322265625 \times 10^{-20}}{6.0351097491868899158617978173424489796161651611328125 \times 10^{-21}} = 2$$

$$\frac{6.0351097491868899158617978173424489796161651611328125 \times 10^{-21}}{3.01755487459344495793089890867122448980808258056640625 \times 10^{-21}} = 2$$

$$\frac{3.01755487459344495793089890867122448980808258056640625 \times 10^{-21}}{1.508777437296722478965449454335612244904041290283203125 \times 10^{-21}} = 2$$

$$\frac{1.508777437296722478965449454335612244904041290283203125 \times 10^{-21}}{7.543887186483612394827247271678061224520206451416015625 \times 10^{-22}} = 2$$

$$\frac{7.543887186483612394827247271678061224520206451416015625 \times 10^{-22}}{3.7719435932418061974136236358390306122601032257080078125 \times 10^{-22}} = 2$$

$$\frac{3.7719435932418061974136236358390306122601032257080078125 \times 10^{-22}}{1.88597179662090309870681181791951530613005161285400390625 \times 10^{-22}} = 2$$

$$\frac{1.88597179662090309870681181791951530613005161285400390625 \times 10^{-22}}{9.42985898310451549353405908959757653065025806427001953125 \times 10^{-23}} = 2$$

$$\frac{9.42985898310451549353405908959757653065025806427001953125 \times 10^{-23}}{4.714929491552257746767029544798788265325129032135009765625 \times 10^{-23}} = 2$$

$$\frac{4.714929491552257746767029544798788265325129032135009765625 \times 10^{-23}}{2.3574647457761288733835147723993941326625645160675048828125 \times 10^{-23}} = 2$$

$$\frac{2.3574647457761288733835147723993941326625645160675048828125 \times 10^{-23}}{1.17873237288806443669175738619969706633128225803375244140625 \times 10^{-23}} = 2$$

$$\frac{1.17873237288806443669175738619969706633128225803375244140625 \times 10^{-23}}{5.89366186444032218345878693099848533165641129016876220703125 \times 10^{-24}} = 2$$

$$\frac{5.89366186444032218345878693099848533165641129016876220703125 \times 10^{-24}}{2.946830932220161091729393465499242665828205645084381103515625 \times 10^{-24}} = 2$$

$$\frac{2.946830932220161091729393465499242665828205645084381103515625 \times 10^{-24}}{1.4734154661100805458646967327496213329141028225421905517578125 \times 10^{-24}} = 2$$

$$\frac{1.4734154661100805458646967327496213329141028225421905517578125 \times 10^{-24}}{7.3670773305504027293234836637481066645705141127109527587890625 \times 10^{-25}} = 2$$

$$\frac{7.3670773305504027293234836637481066645705141127109527587890625 \times 10^{-25}}{3.68353866527520136466174183187405333228525705635547637939453125 \times 10^{-25}} = 2$$

$$\frac{3.68353866527520136466174183187405333228525705635547637939453125 \times 10^{-25}}{1.841769332637600682330870915937026666142628528177738189697265625 \times 10^{-25}} = 2$$

$$\frac{1.841769332637600682330870915937026666142628528177738189697265625 \times 10^{-25}}{9.208846663188003411654354579685133330713142640888690948486328125 \times 10^{-26}} = 2$$

$$\frac{9.208846663188003411654354579685133330713142640888690948486328125 \times 10^{-26}}{4.6044233315940017058271772898425666653565713204443454742431640625 \times 10^{-26}} = 2$$

$$\frac{4.6044233315940017058271772898425666653565713204443454742431640625 \times 10^{-26}}{2.30221166579700085291358864492128333267828566022217273712158203125 \times 10^{-26}} = 2$$

$$\frac{2.30221166579700085291358864492128333267828566022217273712158203125 \times 10^{-26}}{1.151105832898500426456794322460641666339142830111086368560791015625 \times 10^{-26}} = 2$$

$$\frac{1.151105832898500426456794322460641666339142830111086368560791015625 \times 10^{-26}}{5.755529164492502132283971612303208331695714150555431842803955078125 \times 10^{-27}} = 2$$

$$\frac{5.755529164492502132283971612303208331695714150555431842803955078125 \times 10^{-27}}{2.8777645822462510661419858061516041658478570752777159214019775390625 \times 10^{-27}} = 2$$

$$\frac{2.8777645822462510661419858061516041658478570752777159214019775390625 \times 10^{-27}}{1.43888229112312553307099290307580208292392853763885796070098876953125 \times 10^{-27}} = 2$$

$$\frac{1.43888229112312553307099290307580208292392853763885796070098876953125 \times 10^{-27}}{7.19441145561562766535496451537901041461964268819428980350494384765625 \times 10^{-28}} = 2$$

$$\frac{7.19441145561562766535496451537901041461964268819428980350494384765625 \times 10^{-28}}{3.597205727807813832677482257689505207309821344097144901752471923828125 \times 10^{-28}} = 2$$

$$\frac{3.597205727807813832677482257689505207309821344097144901752471923828125 \times 10^{-28}}{1.7986028639039069163387411288447526036549106720485724508762359619140625 \times 10^{-28}} = 2$$

$$\frac{1.7986028639039069163387411288447526036549106720485724508762359619140625 \times 10^{-28}}{8.9930143195195345816937056442237630182745533602428622543811798095703125 \times 10^{-29}} = 2$$

$$\frac{8.9930143195195345816937056442237630182745533602428622543811798095703125 \times 10^{-29}}{4.49650715975976729084685282211188150913727668012143112719058990478515625 \times 10^{-29}} = 2$$

$$\frac{4.49650715975976729084685282211188150913727668012143112719058990478515625 \times 10^{-29}}{2.248253579879883645423426411055940754568638340060715563595294952392578125 \times 10^{-29}} = 2$$

$$\frac{2.248253579879883645423426411055940754568638340060715563595294952392578125 \times 10^{-29}}{1.1241267899399418227117132055279703772843191700303577817976474761962890625 \times 10^{-29}} = 2$$

$$\frac{1.1241267899399418227117132055279703772843191700303577817976474761962890625 \times 10^{-29}}{5.6206339496997091135585660276398518864215958501517889089882373809814453125 \times 10^{-30}} = 2$$

$$\frac{5.6206339496997091135585660276398518864215958501517889089882373809814453125 \times 10^{-30}}{2.81031697484985455677928301381992594321079792507589445449411869049072265625 \times 10^{-30}} = 2$$

$$\frac{2.81031697484985455677928301381992594321079792507589445449411869049072265625 \times 10^{-30}}{1.405158487424927278389641506909962971605398962537947227247059345245361328125 \times 10^{-30}} = 2$$

$$\frac{1.405158487424927278389641506909962971605398962537947227247059345245361328125 \times 10^{-30}}{7.025792437124636391948207534549814858026994812689736136235296726226640625 \times 10^{-31}} = 2$$

$$\frac{7.025792437124636391948207534549814858026994812689736136235296726226640625 \times 10^{-31}}{3.5128962185623181959741037672749074290134974063448680681176483631133203125 \times 10^{-31}} = 2$$

$$\frac{3.51289621856231819597410376727490742901349740634486$$

Jodi's car used 12 gallons of gas to travel 456 miles. How many miles did her car travel per gallon of gas?

Show your work.

$$\begin{array}{r} 4156 \\ \times 12 \\ \hline 912 \\ 41560 \\ \hline 5472 \end{array}$$

Answer: ~~5472~~ miles per gallon

It cost Jodi \$44.88 to buy 12 gallons of gas. What was the cost per gallon of gas?

Show your work.

$$\begin{array}{r} 44.88 \\ - 12 \\ \hline 44.76 \end{array}$$

Answer: ~~44.76~~

Score Point 0 (out of 3 points)

This response is incorrect. The response provides two incorrect answers (5472 and \$44.76) determined by two mathematically inappropriate procedures.

Additional

Jodi's car used 12 gallons of gas to travel 456 miles. How many miles did her car travel per gallon of gas?

Show your work.

$$\begin{array}{r} 456 \\ - 12 \\ \hline 444 \end{array}$$

Answer: 444 miles per gallon

It cost Jodi \$44.88 to buy 12 gallons of gas. What was the cost per gallon of gas?

Show your work.

$$\begin{array}{r} 44.88 \\ - 12 \\ \hline 44.76 \end{array}$$

Answer: \$44.76

Score Point 0 (out of 3 points)

This response is incorrect. The response provides two incorrect answers (444 and \$44.76) determined by two mathematically inappropriate procedures.