

THE UNIVERSITY OF THE STATE OF NEW YORK

GRADE 4

ELEMENTARY-LEVEL SCIENCE TEST

WRITTEN TEST

JUNE 6, 2011

Student Name _____

School Name _____

Print your name and the name of your school on the lines above.

The test has two parts. Parts I and II are in this test booklet.

Part I contains 30 multiple-choice questions. Record your answers to these questions on the separate answer sheet. Use only a No. 2 pencil on your answer sheet.

Part II consists of 12 open-ended questions. Write your answers to Part II in this test booklet.

You will have as much time as you need to answer the questions.

DO NOT TURN THIS PAGE UNTIL YOU ARE TOLD TO DO SO.

Copyright 2011

THE UNIVERSITY OF THE STATE OF NEW YORK
THE STATE EDUCATION DEPARTMENT
ALBANY, NEW YORK 12234

DIRECTIONS

There are 30 questions on Part I of this test. Each question is followed by three or four choices, labeled A–D. Read each question carefully. Decide which choice is the best answer. On the separate answer sheet, mark your answer in the row of circles for each question by filling in the circle that has the same letter as the answer you have chosen. Use a No. 2 pencil to mark the answer sheet.

Read Sample Question **S-1** below.

S-1 Frozen water is called

- A fog
- B ice
- C steam
- D vapor

The correct answer is **ice**, which is next to letter **B**. On your answer sheet, look at the box showing the row of answer circles for Sample Question **S-1**. See how the circle for letter **B** has been filled in.

Now do Sample Question **S-2**. Mark your answer on the answer sheet in the box showing the row of answer circles for Sample Question **S-2**.

S-2 Which animal has wings?

- A bird
- B frog
- C mouse
- D rabbit

The correct answer is **bird**, which is next to letter **A**. On your answer sheet, you should have filled in circle **A**.

Answer all 30 questions on Part I of this test. Fill in only one circle for each question. Be sure to erase completely any answer you want to change. You may not know the answers to some of the questions, but do the best you can on each one.

When you have finished Part I, go on to Part II. Answer all of the questions in Part II in the space for each question.

Part I

- 1 The diagram below shows a balance. Side *A* has five blocks and side *B* has three blocks. The mass of each block is shown in grams (g).

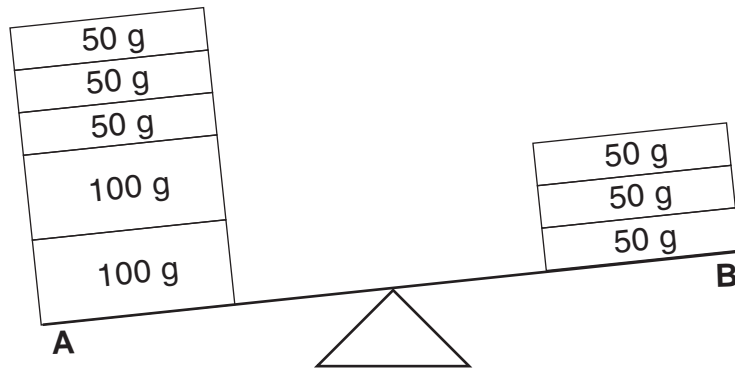





















How much greater is the mass of the blocks on side *A* than the mass of the blocks on side *B*?

- A 50 g
- B 100 g
- C 150 g
- D 200 g

Note that question 2 has only three choices.

- 2 How does the length of daylight in New York State change from summer to fall?
- A It decreases.
 - B It increases.
 - C It remains the same.
- 3 Which two observations are both used to describe weather?
- A precipitation and runoff
 - B temperature and sky conditions
 - C wind speed and erosion
 - D types of clouds and deposition

4 A calendar for the month of September 2003 is shown below.

September 2003						
Sun	Mon	Tue	Wed	Thur	Fri	Sat
	1 	2 	3  Q	4 	5 	6 
7 	8 	9 	10  F	11 	12 	13 
14 	15 	16 	17 	18  Q	19 	20 
21 	22 	23 	24 	25  N	26  N	27  N
28 	29 	30 				

www.calculatorcat.com (adapted)

The calendar shows the changing appearance of

- A the Sun
 - B the Moon
 - C the stars
 - D Earth
- 5 It rained on a hot summer afternoon and a puddle formed. After several hours, the puddle was gone. Which two processes made the puddle form and then disappear?
- A precipitation followed by evaporation
 - B deposition followed by evaporation
 - C precipitation followed by runoff
 - D deposition followed by runoff
- 6 Which force causes rocks to roll downhill?
- A gravity
 - B friction
 - C erosion
 - D magnetism

7 Which unit of measurement describes an object's length?

- A meter
- B kilogram
- C liter
- D degree

8 Which sense is used to determine an object's texture?

- A hearing
- B smell
- C taste
- D touch

9 The diagram below shows a solid piece of chocolate before it was melted and the same piece of chocolate after it was melted into a liquid.



Solid chocolate



Liquid chocolate

Which property of the piece of chocolate is the same in the two diagrams?

- A mass
- B shape
- C temperature
- D texture

10 Which form of energy is found in food?

- A chemical
- B electrical
- C sound
- D mechanical

11 A student crumples up a sheet of paper. Which property of the paper has changed?

- A color
- B mass
- C state
- D shape

12 The diagram below shows a bell ringing.

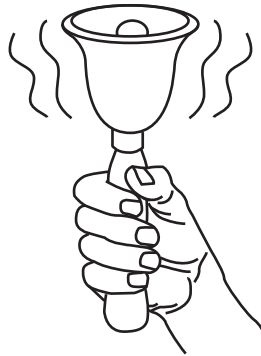

Which form of energy is produced when a bell rings?

- A magnetic
- B electrical
- C sound
- D light

13 A student riding a bicycle observes that it moves faster on a smooth road than on a rough road. This happens because the smooth road has

- A less gravity
- B more gravity
- C less friction
- D more friction

14 The diagram below shows a pan of boiling water on a stove.

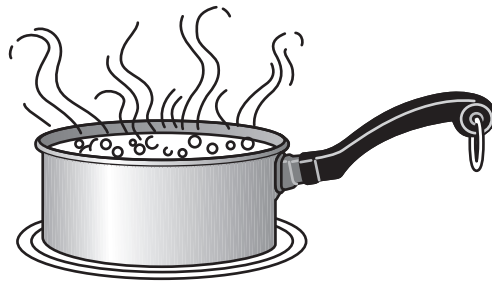

Which form of energy changes the water from a liquid to a gas as it boils?

- A sound
- B mechanical
- C light
- D heat

15 Which object is *nonliving*?

- A bear
- B bicycle
- C bird
- D butterfly

16 An example of a learned trait is

- A being able to read
- B being able to breathe
- C having a scar
- D having brown eyes

17 The diagram below shows a mature flower.



Mature flower

This flower produced seeds that grew into new flowers. Which new flower is most likely an offspring of this mature flower?



A



B



C



D

18 The diagram below shows a baby elephant with one of its parents.

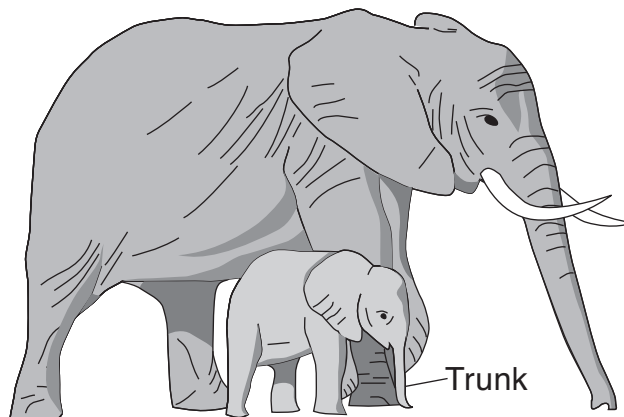

The baby elephant's trunk is an example of

- A a response to the environment
- B an inherited trait
- C coloration to attract mates
- D a seasonal adaptation

Base your answers to questions 19 and 20 on the diagram below, which shows four stages in the growth and development of a bean plant. The stages are labeled *A*, *B*, *C*, and *D*.

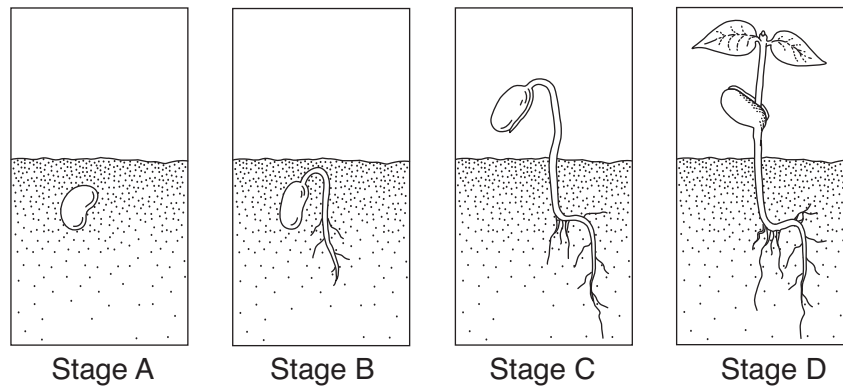

19 In which stage is germination first visible?

- A *A*
- B *B*
- C *C*
- D *D*

20 Which new structure first appears in stage *D*?

- A seed
- B leaf
- C root
- D stem

- 21 The diagram below shows four stages in the life cycle of a butterfly. One stage is labeled X.

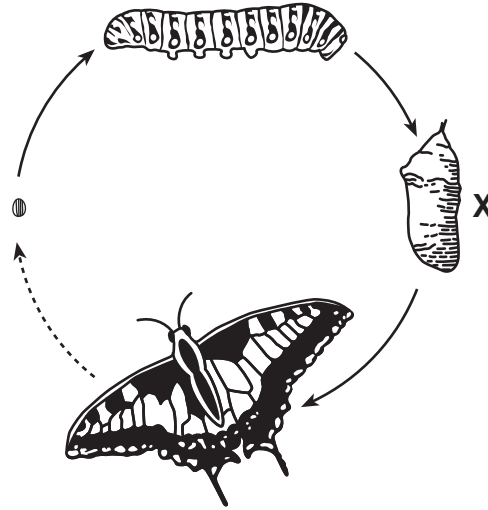

(Not drawn to scale)

Which stage is shown at X?

- A larva
 - B egg
 - C adult
 - D pupa
- 22 Which two activities are carried out by all species of living things?
- A make food and eliminate waste
 - B hibernate and take in nutrients
 - C grow and reproduce
 - D migrate and seek shelter
- 23 A fox grows thicker fur as a season changes. This adaptation helps the fox to
- A find food
 - B keep warmer
 - C grow stronger
 - D escape from predators

- 24** Which activity is an example of a good health habit?
- A watching television
 - B smoking cigarettes
 - C eating candy
 - D exercising every day
- 25** A decomposer is an organism that
- A hunts and eats animals
 - B migrates for the winter
 - C breaks down dead plants and animals
 - D uses water and sunlight to make food
- 26** What is the main source of energy for the water cycle?
- A electricity
 - B erosion
 - C gravity
 - D sunlight
- 27** Which human activity is most harmful to the natural environment?
- A swimming in a lake
 - B riding a bicycle
 - C cutting down a rain forest
 - D using solar energy

Base your answers to questions 28 through 30 on the diagram below and on your knowledge of science. The diagram shows a relationship between several organisms, labeled *A*, *B*, *C*, and *D*.

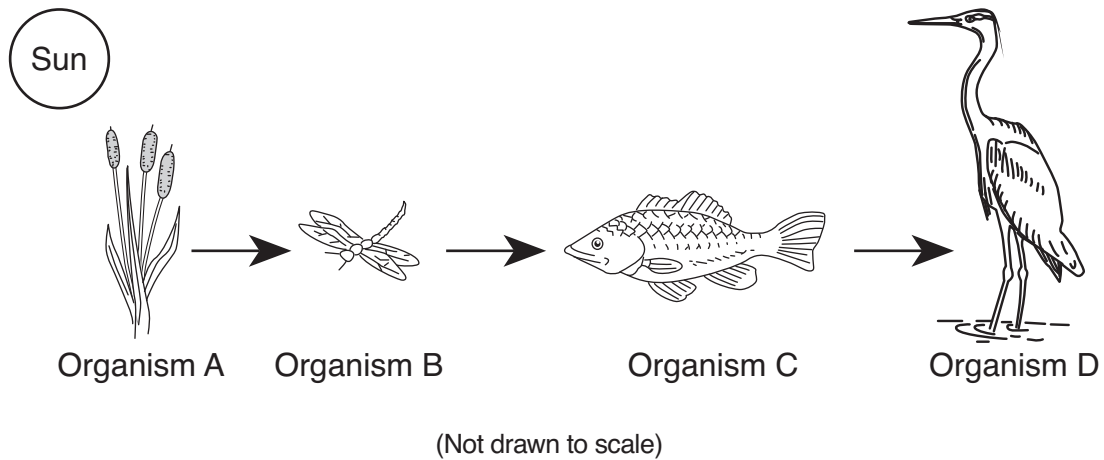

28 The sequence shown in this diagram represents a

- A life span
- B food chain
- C water cycle
- D seed germinating

29 Which organism in the diagram is a producer?

- A *A*
- B *B*
- C *C*
- D *D*

30 Which organism in the diagram is both predator and prey?

- A *A*
- B *B*
- C *C*
- D *D*

Part II

Directions (31–42): Record your answers in the space provided below each question.

- 31** A cup of water was heated for eight minutes. The thermometers below show the temperature readings during that time.

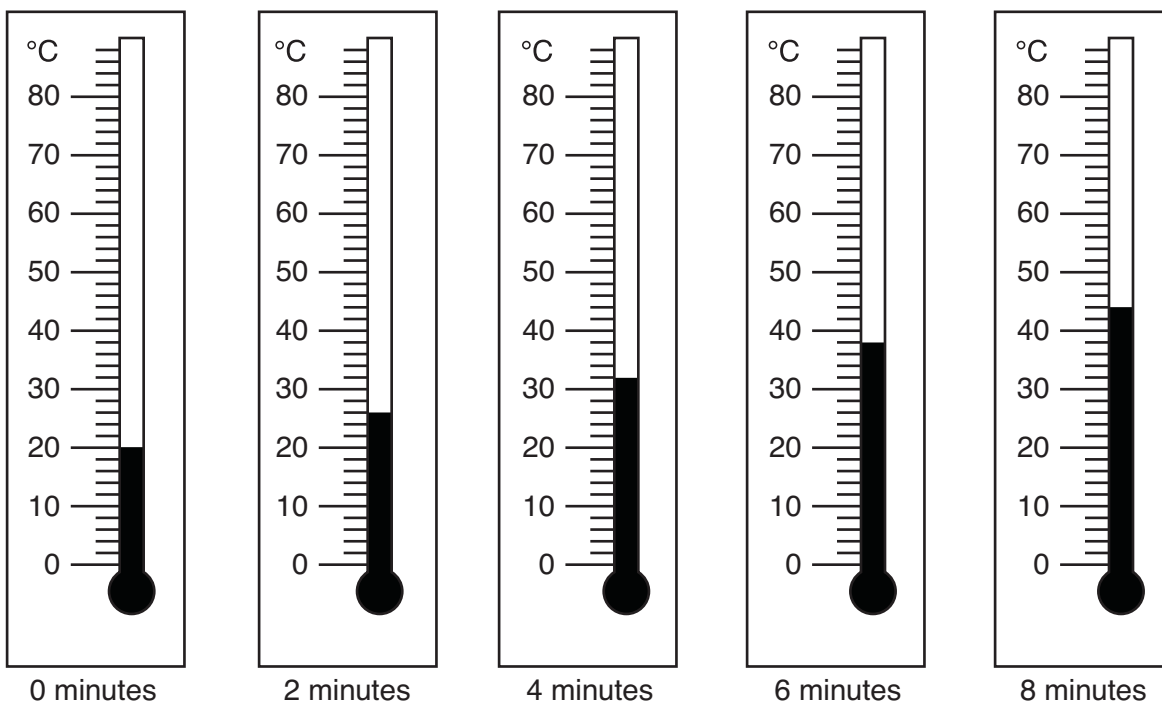

Estimate the temperature of the water when it was heated for three minutes. [1]

_____ °C

32 The data table below shows the times of sunrise and sunset for a city in New York State for a week. The times for day 4 are *not* shown.

Sunrise and Sunset Times for a Week

Day	Sunrise	Sunset
1	5:42 a.m.	8:22 p.m.
2	5:43 a.m.	8:21 p.m.
3	5:44 a.m.	8:20 p.m.
4	???	???
5	5:46 a.m.	8:18 p.m.
6	5:47 a.m.	8:17 p.m.
7	5:48 a.m.	8:16 p.m.

Based on the pattern shown in the data table, what time did sunrise and sunset occur on day 4? [1]

Sunrise: _____ **a.m.** Sunset: _____ **p.m.**

33 Three properties of a block of wood are listed in the chart below. Identify **one** scientific tool that can be used to measure each property. The tool used to measure weight is shown. [2]

Property	Tool
weight	spring scale
height	
mass	

- 34 The diagram below shows an electrical circuit that is open at letter *B*. The lightbulb is *not* lit.

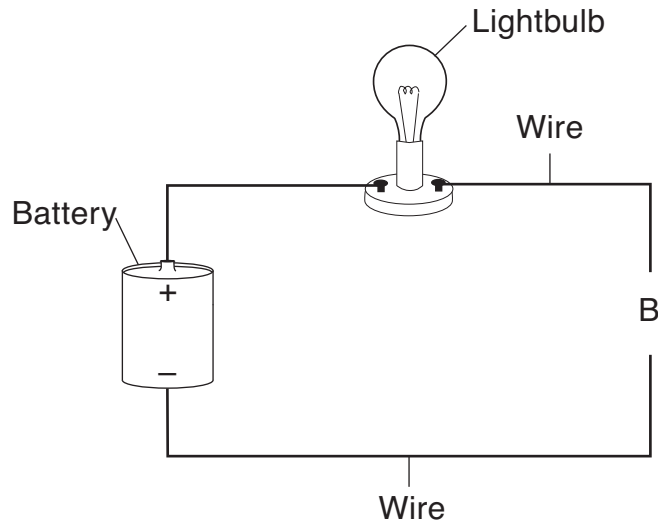

Explain why using a metal paper clip to connect the wires at *B* will light the lightbulb. [1]

35 The diagram below shows five boxes labeled *A*, *B*, *C*, *D*, and *E*. The mass of each box is shown.

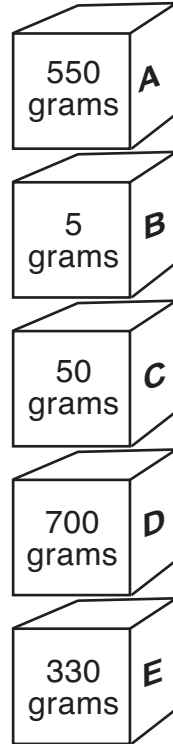

Write the letter of the box that is under the box with a mass of 700 grams. [1]

36 Diagrams *A*, *B*, and *C* below show a person using three different simple machines to move a box.

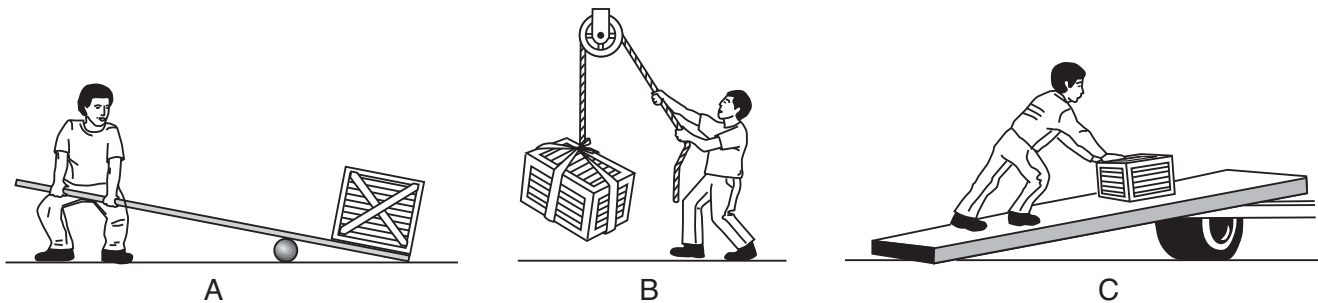

The chart below lists these three simple machines. Complete the chart by writing the letter of the diagram to show which simple machine is being used to move the box. [1]

Simple Machine	Diagram Letter
pulley	
inclined plane	
lever	

37 The diagram below shows three pairs of identical magnets labeled *A*, *B*, and *C*. The distance between each pair of magnets is shown in centimeters (cm).

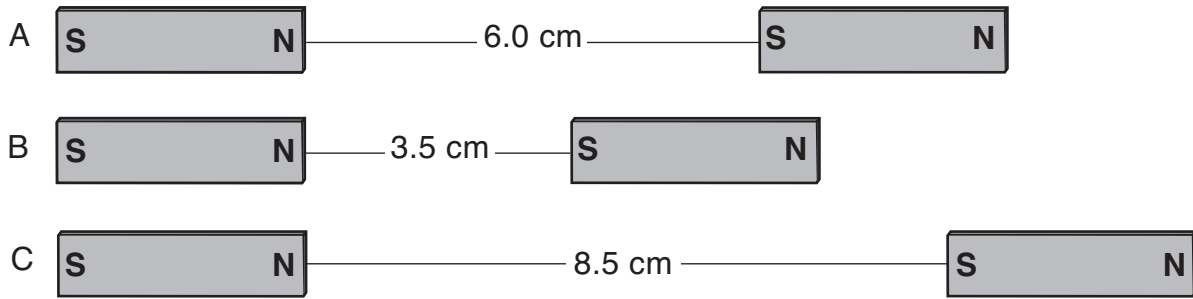

Explain why the pair of magnets at *B* will have the strongest force of attraction between them. [1]

Base your answers to questions 38 and 39 on the diagram below and on your knowledge of science. The diagram shows a green plant. Four parts of the plant are labeled.

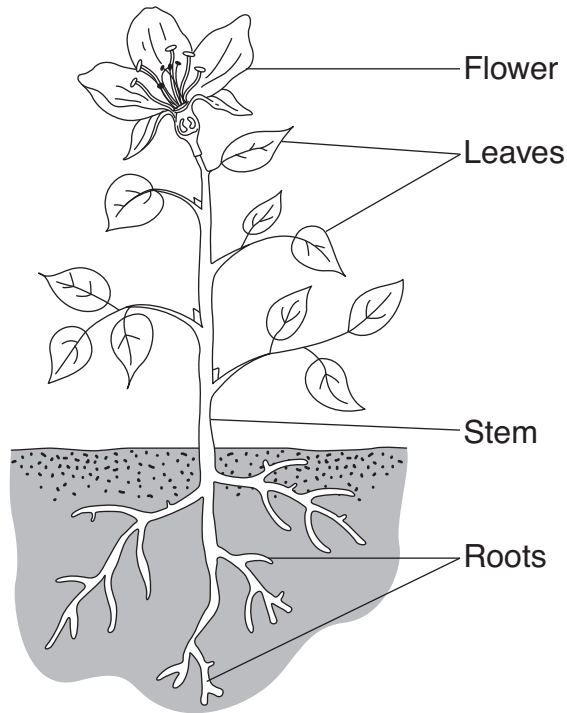

38 Describe **two** functions of the roots. [2]

(1) _____

(2) _____

39 Identify **two** things from the environment that a green plant needs to survive. [1]

_____ and _____

40 Plants' seeds are dispersed (spread) in different ways. Describe **two** ways that a plant's seeds can be dispersed. [2]

(1) _____

(2) _____

41 The paragraph below gives some facts about a type of turtle.

The turtle eats grass and smaller animals. The colors on its shell allow it to blend in with the forest floor. The turtle moves slower than its predators, such as foxes. When the turtle senses danger, it hides inside its hard shell.

Describe **two** ways that the turtle is protected from predators. [1]

(1) _____

(2) _____

42 A student made some observations of two objects, *A* and *B*. The chart below shows these observations.

Object A	Object B
cardboard	wood
brown	brown
cube	cube
smooth	rough

A Venn diagram can be used to compare and contrast objects *A* and *B*. Complete the Venn diagram below. Use **all** of the observations from the chart. [1]

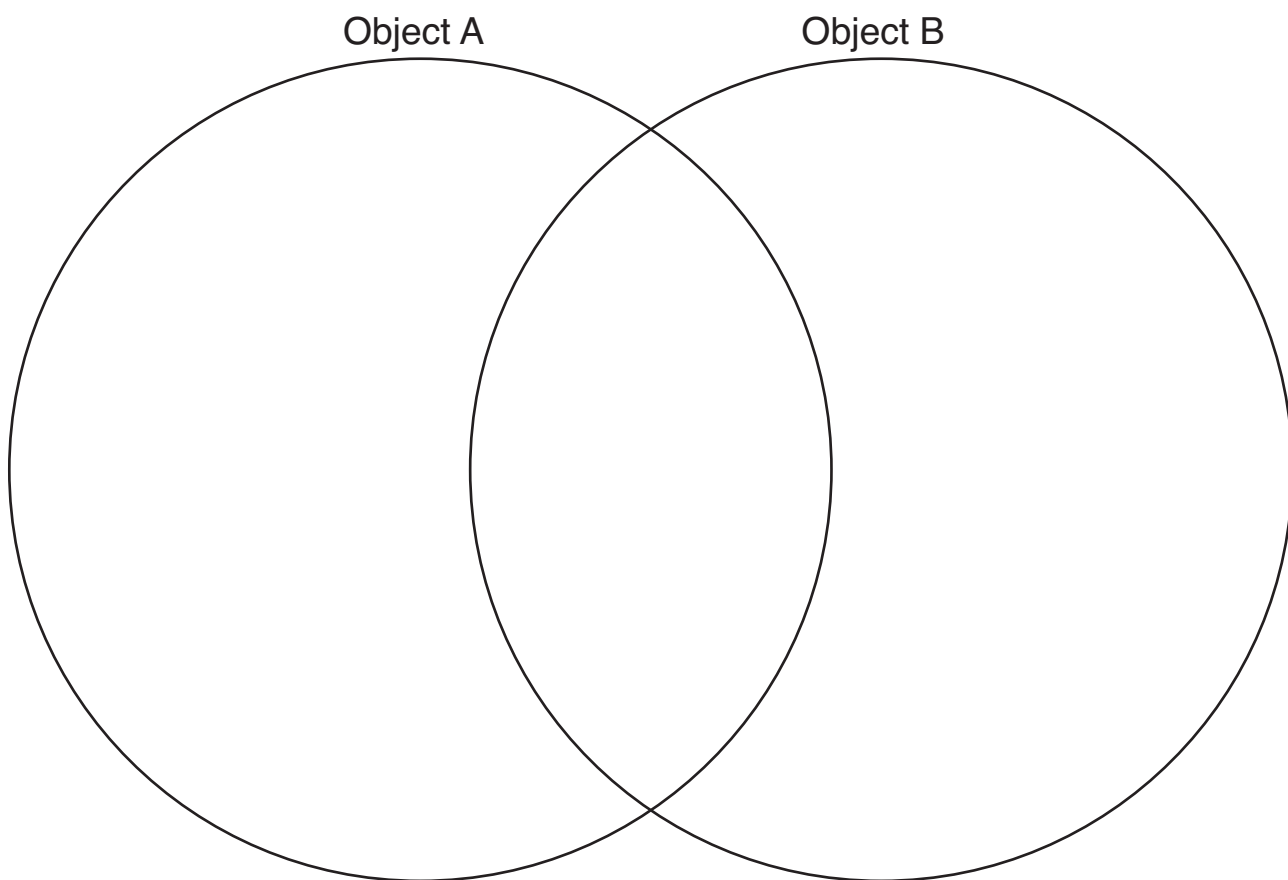

GRADE 4 ELEMENTARY-LEVEL SCIENCE

For Teacher Use Only Part II Credit

Question	Maximum Credit	Credit Allowed
31	1	
32	1	
33	2	
34	1	
35	1	
36	1	
37	1	
38	2	
39	1	
40	2	
41	1	
42	1	
Total	15	