

PHYSICAL SETTING EARTH SCIENCE

Friday, August 17, 2012 — 12:30 to 3:30 p.m., only

Use your knowledge of Earth science to answer all questions in this examination. Before you begin this examination, you must be provided with the *2011 Edition Reference Tables for Physical Setting/Earth Science*. You will need these reference tables to answer some of the questions.

You are to answer all questions in all parts of this examination. You may use scrap paper to work out the answers to the questions, but be sure to record your answers on your answer sheet and in your answer booklet. A separate answer sheet for Part A and Part B–1 has been provided to you. Follow the instructions from the proctor for completing the student information on your answer sheet. Record your answers to the Part A and Part B–1 multiple-choice questions on this separate answer sheet. Record your answers for the questions in Part B–2 and Part C in your separate answer booklet. Be sure to fill in the heading on the front of your answer booklet.

All answers in your answer booklet should be written in pen, except for graphs and drawings, which should be done in pencil.

When you have completed the examination, you must sign the declaration printed on your separate answer sheet, indicating that you had no unlawful knowledge of the questions or answers prior to the examination and that you have neither given nor received assistance in answering any of the questions during the examination. Your answer sheet and answer booklet cannot be accepted if you fail to sign this declaration.

Notice. . .

A four-function or scientific calculator and a copy of the *2011 Edition Reference Tables for Physical Setting/Earth Science* must be available for you to use while taking this examination.

The use of any communications device is strictly prohibited when taking this examination. If you use any communications device, no matter how briefly, your examination will be invalidated and no score will be calculated for you.

DO NOT OPEN THIS EXAMINATION BOOKLET UNTIL THE SIGNAL IS GIVEN.

Part A

Answer all questions in this part.

Directions (1–35): For *each* statement or question, choose the word or expression that, of those given, best completes the statement or answers the question. Some questions may require the use of the *2011 Edition Reference Tables for Physical Setting/Earth Science*. Record your answers on your separate answer sheet.

1 The direction of swing of a Foucault pendulum appears to change due to Earth's

- (1) revolution
- (2) rotation
- (3) spherical shape
- (4) elliptical orbit

2 Great amounts of energy are released in the core of a star as lighter elements combine and form heavier elements during the process of

- (1) compaction
- (2) condensation
- (3) radioactive decay
- (4) nuclear fusion

3 Which sequence of stars is listed in order of increasing luminosity?

- (1) *Spica, Rigel, Deneb, Betelgeuse*
- (2) *Polaris, Deneb, 40 Eridani B, Proxima Centauri*
- (3) *Barnard's Star, Alpha Centauri, Rigel, Spica*
- (4) *Procyon B, Sun, Sirius, Betelgeuse*

4 As Earth travels in its orbit, Earth's axis

- (1) remains parallel to itself at all Earth positions
- (2) remains aligned with the Sun's axis
- (3) is perpendicular to the Moon's axis
- (4) is pointing toward the center of the Milky Way

5 To a nighttime observer on Earth, how many degrees do the stars appear to move around *Polaris* in 3 hours?

- (1) 60°
- (2) 45°
- (3) 3°
- (4) 15°

6 To an observer in New York State, the duration of daylight increases continuously from

- (1) March 1 to May 1
- (2) June 1 to August 1
- (3) September 1 to November 1
- (4) December 1 to February 1

7 The arrows in the diagram below show changes in the direction of surface winds at four lettered locations, A, B, C, and D, on Earth.

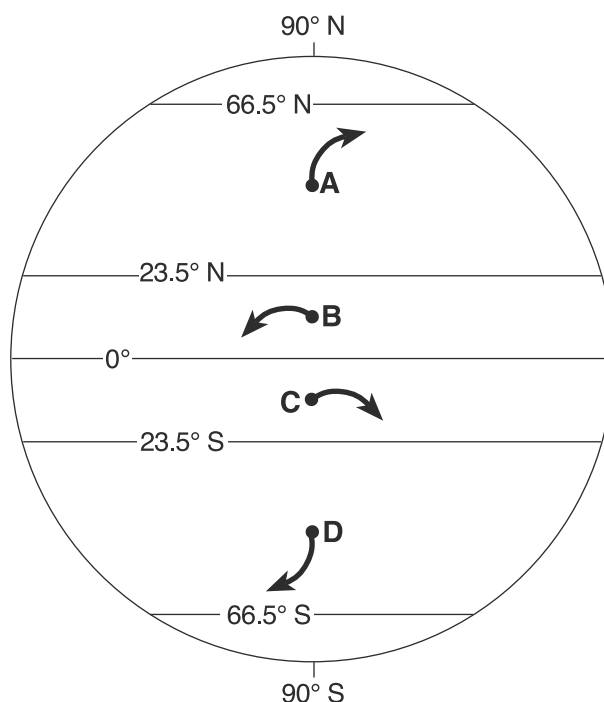

The arrow at which location correctly shows a deflection of the wind that could be due to the Coriolis effect?

- (1) A
- (2) B
- (3) C
- (4) D

8 Approximately 2.2 billion years ago, which gas was first added in large amounts to Earth's atmosphere from life-forms that evolved in the oceans?

- (1) carbon dioxide
- (2) water vapor
- (3) oxygen
- (4) nitrogen

9 Which weather variable generally *decreases* when wind speed is increasing, clouds are thickening, and visibility drops?

- (1) relative humidity
- (2) dewpoint
- (3) precipitation
- (4) air pressure

- 10 The diagram below shows a weather instrument found at most weather stations.

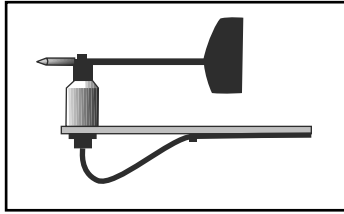

The main function of this instrument is to measure which weather variable?

- (1) wind speed (3) air pressure
 (2) wind direction (4) relative humidity
- 11 What is the approximate percent of oxygen by volume present in Earth's lower atmosphere?
 (1) 21% (3) 46%
 (2) 33% (4) 94%
- 12 Global warming is most likely occurring due to an increase in
 (1) carbon dioxide and methane gases in the atmosphere
 (2) oxygen and nitrogen gases in the atmosphere
 (3) ultraviolet radiation and x rays reflected from Earth
 (4) visible light and radio waves reflected from Earth
- 13 Which geologic event occurred in New York State at the end of the Triassic Period?
 (1) domelike uplift of the Adirondack region
 (2) formation of the Catskill delta
 (3) retreat of the last continental ice
 (4) intrusion of the Palisades sill
- 14 What is the approximate time difference between the first *P*-wave and the first *S*-wave recorded at a seismic station located 8000 kilometers from an earthquake's epicenter?
 (1) 8 minutes 40 seconds
 (2) 9 minutes 20 seconds
 (3) 11 minutes 20 seconds
 (4) 20 minutes 40 seconds

- 15 In which Earth layer does the pressure reach 3.5 million atmospheres?

- (1) crust (3) outer core
 (2) stiffer mantle (4) inner core
- 16 Which surface feature was produced by crustal movements at a transform plate boundary?
 (1) East African Rift (3) Tasman Hot Spot
 (2) Aleutian Trench (4) San Andreas Fault

- 17 The block diagram below shows part of a meandering stream. Line *XY* shows the location of a stream cross section.

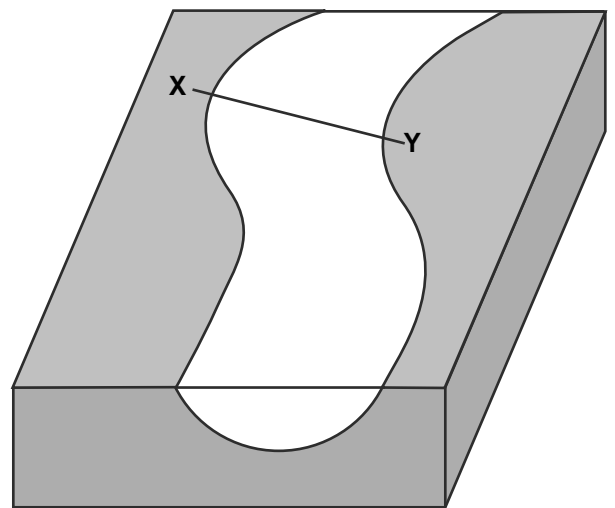

Which cross section best represents the shape of the stream channel at line *XY*?

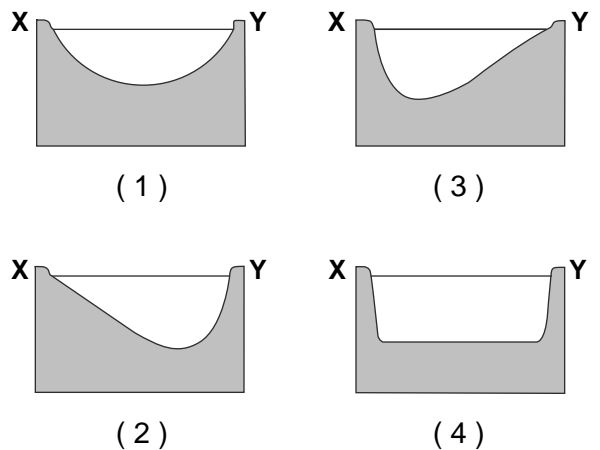

18 Which type of surface bedrock is most commonly found in New York State's Tug Hill Plateau region?

- (1) intrusive igneous rock layers
- (2) extrusive igneous rock layers
- (3) horizontal sedimentary rock layers
- (4) faulted metamorphic rock layers

19 The cross section below shows layers of sediments deposited in a region of Wisconsin that has experienced several periods of glaciation. Descriptions of the sediments in layers A through F are included.

Layer	Sediment Description
A	Clay
B	Red mixed sediments
C	Clay, silt, and sand
D	Forest bed clay
E	Red and gray clays with lenses of silt and sand
F	Gray mixed sediments

Source: A. N. Strahler, *The Earth Sciences*, 2nd Edition, 1971 (adapted)

Which two layers of sediments were probably deposited directly by glaciers?

- (1) A and D
- (2) B and F
- (3) C and E
- (4) D and E

20 A river's current carries sediments into the ocean. Which sediment size will most likely be deposited in deeper water farthest from the shore?

- (1) pebble
- (2) sand
- (3) silt
- (4) clay

21 Which mineral would most likely become rounded at the fastest rate when tumbled along a stream bottom?

- (1) garnet
- (2) pyroxene
- (3) plagioclase feldspar
- (4) selenite gypsum

22 Mineral crystals of quartz, biotite mica, and amphibole are produced primarily by the

- (1) chemical reaction of elements in seawater
- (2) cooling and solidification of magma
- (3) deposition of sediments by a glacier
- (4) metamorphism of bituminous coal

23 Which texture best describes an igneous rock that formed deep underground?

- (1) glassy
- (2) vesicular
- (3) fine grained
- (4) coarse grained

24 A nonvesicular rock is made entirely of green 2-millimeter-diameter crystals that have a hardness of 6.5 and show fracture, but *not* cleavage. The rock is most likely

- (1) shale
- (2) phyllite
- (3) dunite
- (4) schist

25 The diagram below shows the Moon at one position in its orbit around Earth. Letter X indicates the location of an observer in New York State.

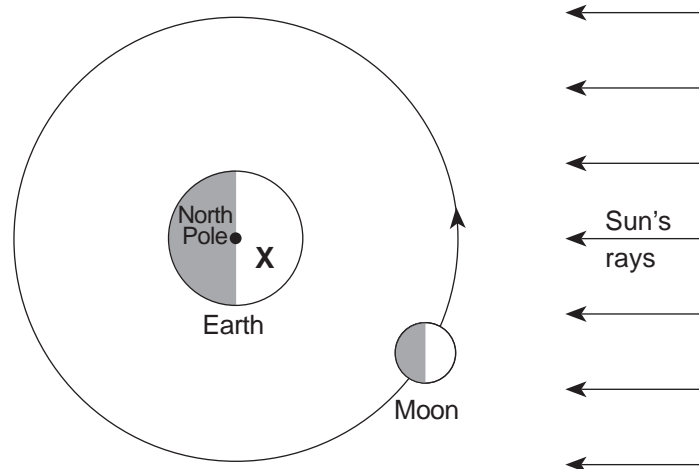

(Not drawn to scale)

Which phase of the Moon will the observer see when the Moon is at the position shown in its orbit?

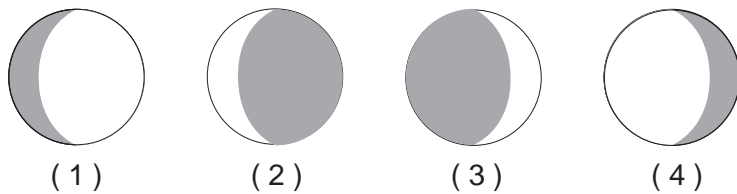

26 The photographs below show the same coastal location at two different times during the same day.



People on Beach
12:40 p.m.



People Boating
6:52 p.m.

Source: thehopewellrocks.ca (adapted)

Which statement best explains the cause for the higher water level at 6:52 p.m.?

- (1) The Moon rotates on its axis at the same rate that it revolves around Earth.
- (2) The Moon exerts a gravitational pull on a rotating Earth.
- (3) Earth's rotation causes a deflection of surface ocean currents.
- (4) Earth's tilted axis causes different amounts of insolation throughout the day.

27 Which bar graph best represents the equatorial diameters of the eight planets of our solar system?

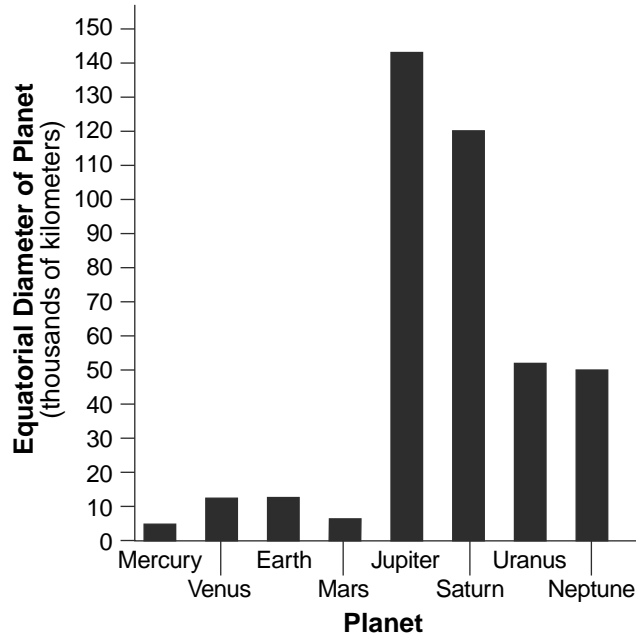

(1)

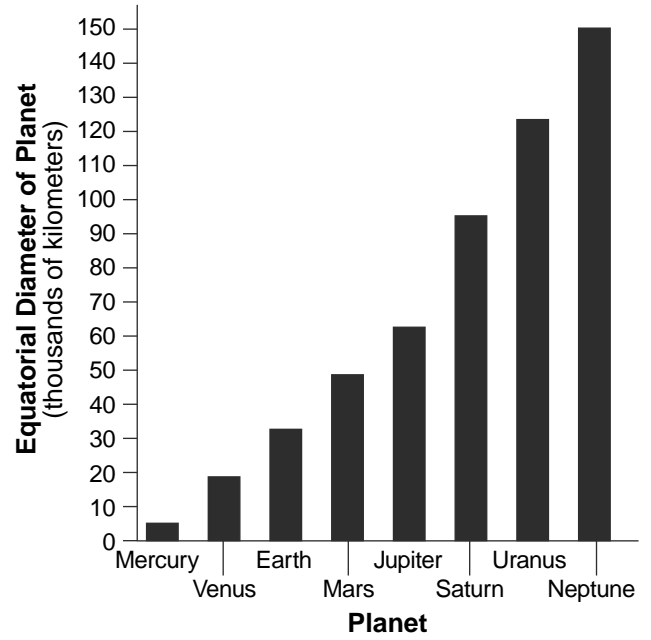

(3)

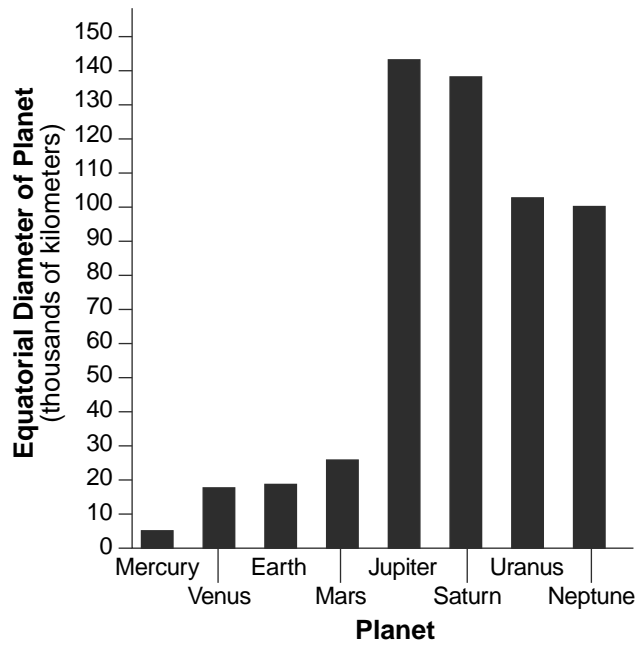

(2)

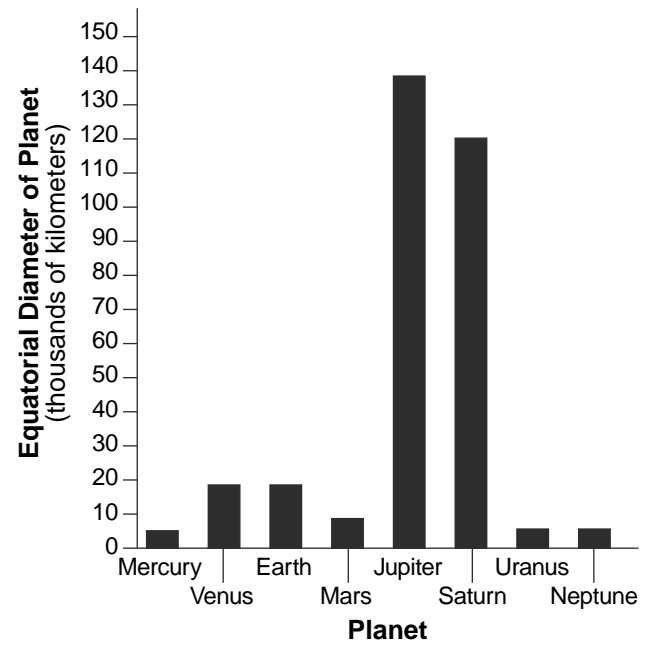

(4)

28 Which diagram represents the apparent path of the Sun on March 21 for an observer at the equator?

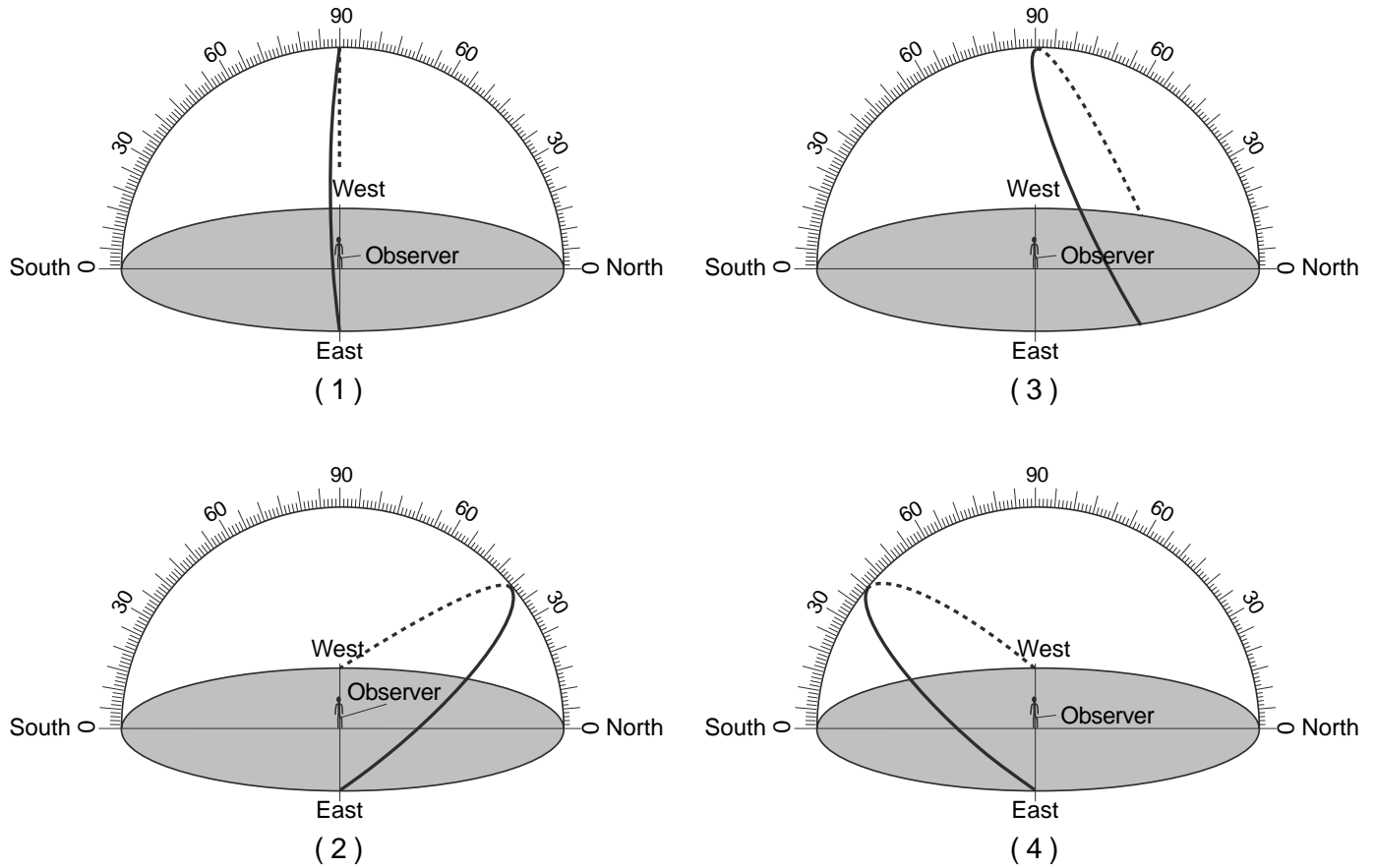

29 The arrows in the diagram below represent processes in the water cycle.

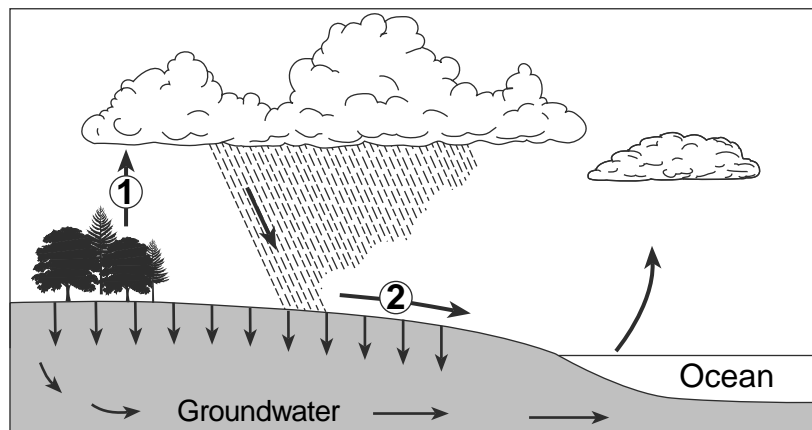

Which processes in the water cycle are identified by the numbered arrows?

- (1) Process 1 is transpiration; process 2 is runoff.
- (2) Process 1 is precipitation; process 2 is runoff.
- (3) Process 1 is condensation; process 2 is infiltration.
- (4) Process 1 is evaporation; process 2 is infiltration.

30 The diagram below represents the setup for an experiment for studying groundwater. Tubes A, B, C, and D contain equal volumes of sediments. Within each tube, the sediments are uniform in size, shape, and packing. A test for water retention was conducted by first filling each tube with water and then draining the water into beakers.

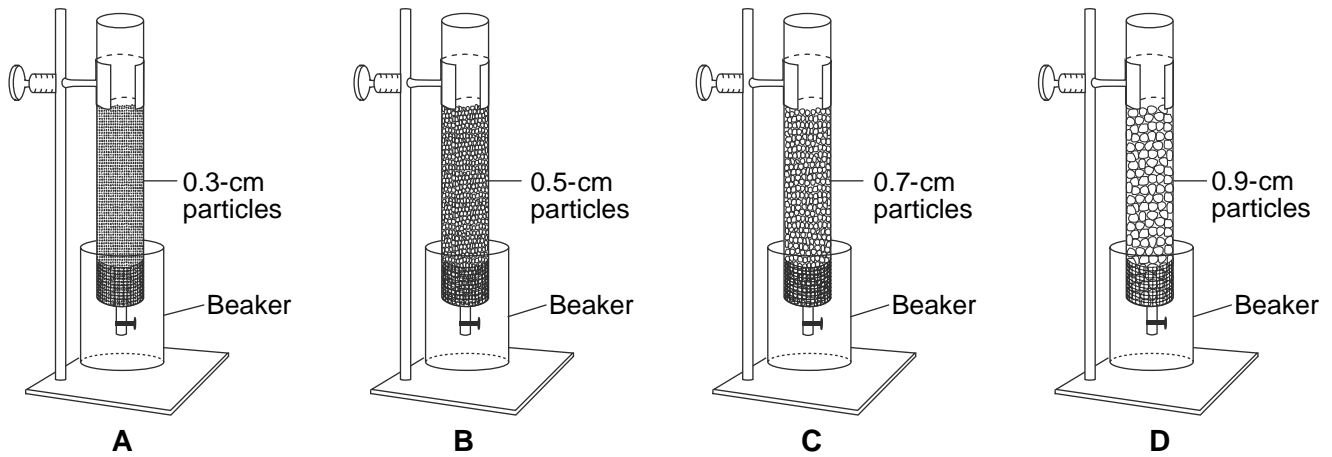

(Not drawn to scale)

Which graph represents the general relationship between the sediment size and the amount of water retained by the sediments after the tubes had drained?

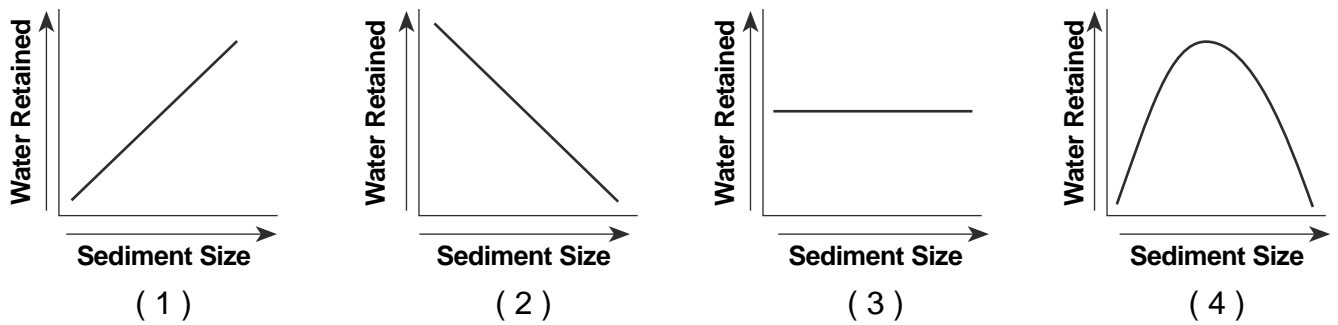

31 The geologic cross section below shows several rock units of Earth's crust. Some rock units are labeled A through E.

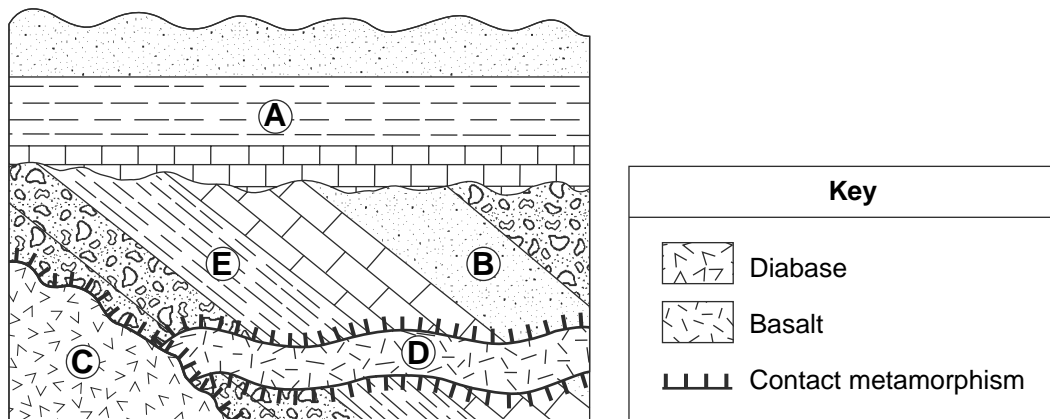

Which two rock units formed from sediments deposited in horizontal layers?

- (1) A and B
- (2) B and C
- (3) C and D
- (4) D and E

32 Weather station models for three New York State cities on the same day at the same time are shown below.

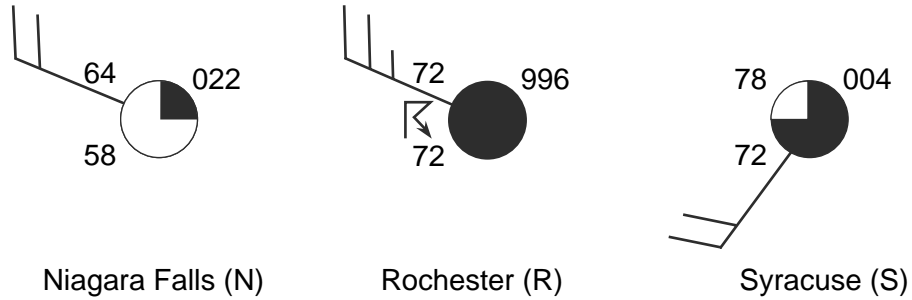

Which map shows the front that was most likely passing through Rochester at that time?

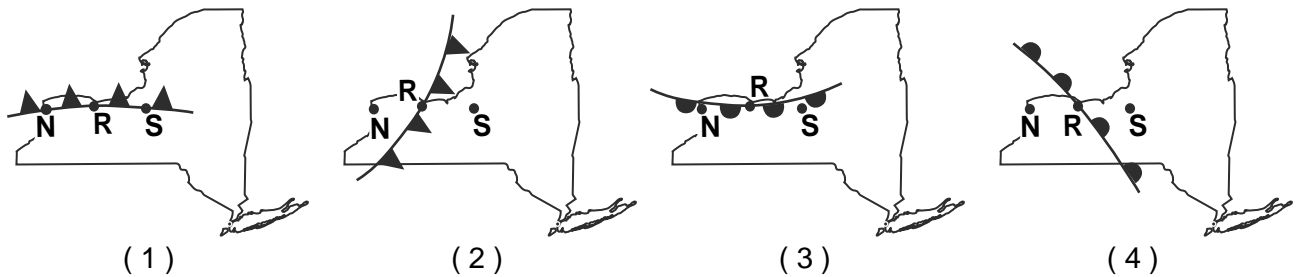

33 Arrows on the maps below show differences in the direction of winds in the region of India and the Indian Ocean during January and July. Isobar values are recorded in millibars.

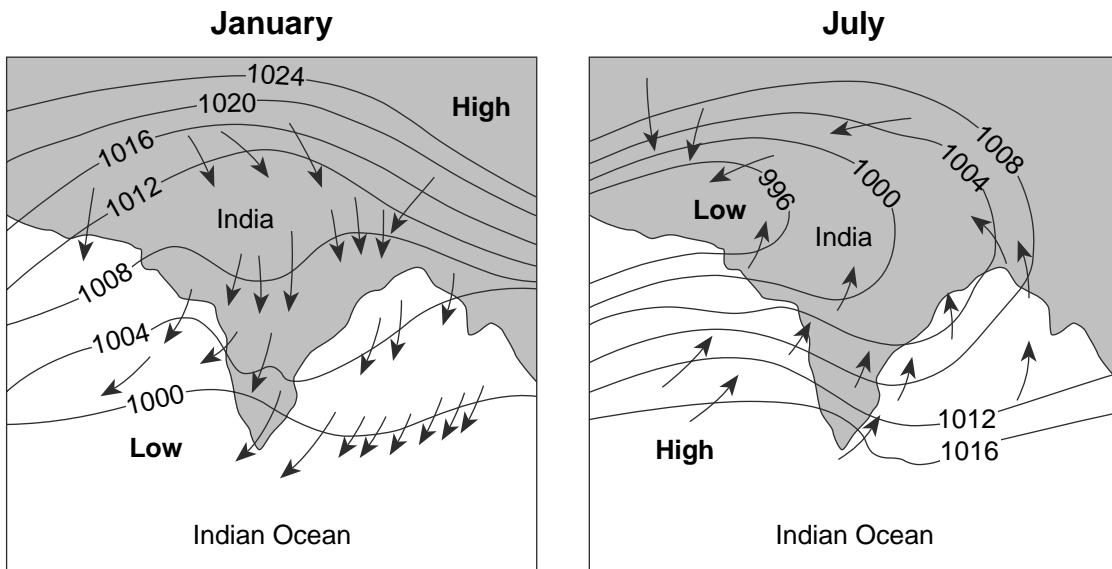

Heavy monsoon rains usually occur in India during

- (1) January, when winds blow from the land
- (2) January, when winds blow toward high pressure

- (3) July, when winds blow from the ocean
- (4) July, when winds blow toward high pressure

34 Which cross section best represents the convection currents in the mantle beneath the Peru-Chile Trench?

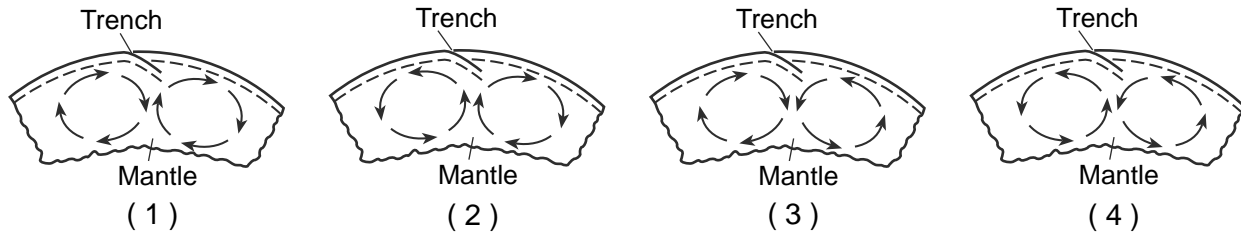

35 The sequence of block diagrams below shows stages of development of a landscape. The stages are labeled A, B, and C.

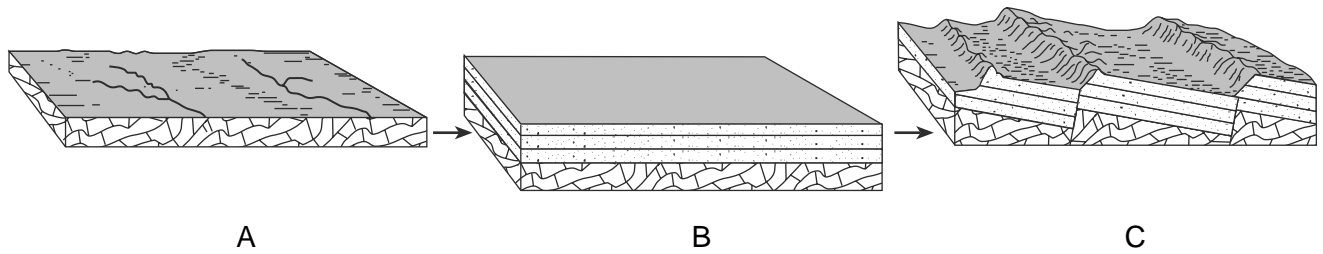

Which sequence of geologic processes best describes the events that created each stage shown?

- (1) erosion → subsidence and deposition → uplift and faulting
- (2) uplift and deposition → flooding → folding and erosion
- (3) metamorphism → erosion and deposition → volcanic eruptions
- (4) uplift and erosion → subsidence and erosion → folding

Part B-1

Answer all questions in this part.

Directions (36–50): For *each* statement or question, choose the word or expression that, of those given, best completes the statement or answers the question. Some questions may require the use of the *2011 Edition Reference Tables for Physical Setting/Earth Science*. Record your answers on your separate answer sheet.

Base your answers to questions 36 and 37 on the data table below. The table shows the percentage of original carbon-14 remaining in three different fossils. The approximate ages of the gastropod shell and the tree wood are shown in years. The age of the human bone has been left blank.

Data Table

Fossil	Original ¹⁴C Remaining (%)	Approximate Age (y)
gastropod shell	50	5,700
tree wood	25	11,400
human bone	12.5	

36 What is the approximate age of the human bone fossil?

- (1) 5,700 y
- (2) 17,100 y
- (3) 22,800 y
- (4) 39,900 y

37 During which geologic period did all three fossils form?

- (1) Quaternary
 - (2) Neogene
 - (3) Paleogene
 - (4) Permian
-

Base your answers to questions 38 through 41 on the passage and map below. The map shows sections of the Atlantic Ocean, the Caribbean Sea, and the Gulf of Mexico.

Shipwreck

In 1641, the crew of the ship *Concepcion* used the Sun and stars for navigation. The crew thought that the ship was just north of Puerto Rico, but ocean currents had carried them off course. The ship hit a coral reef and sank off the coast of the Dominican Republic. The **X** on the map marks the location of the sunken ship.

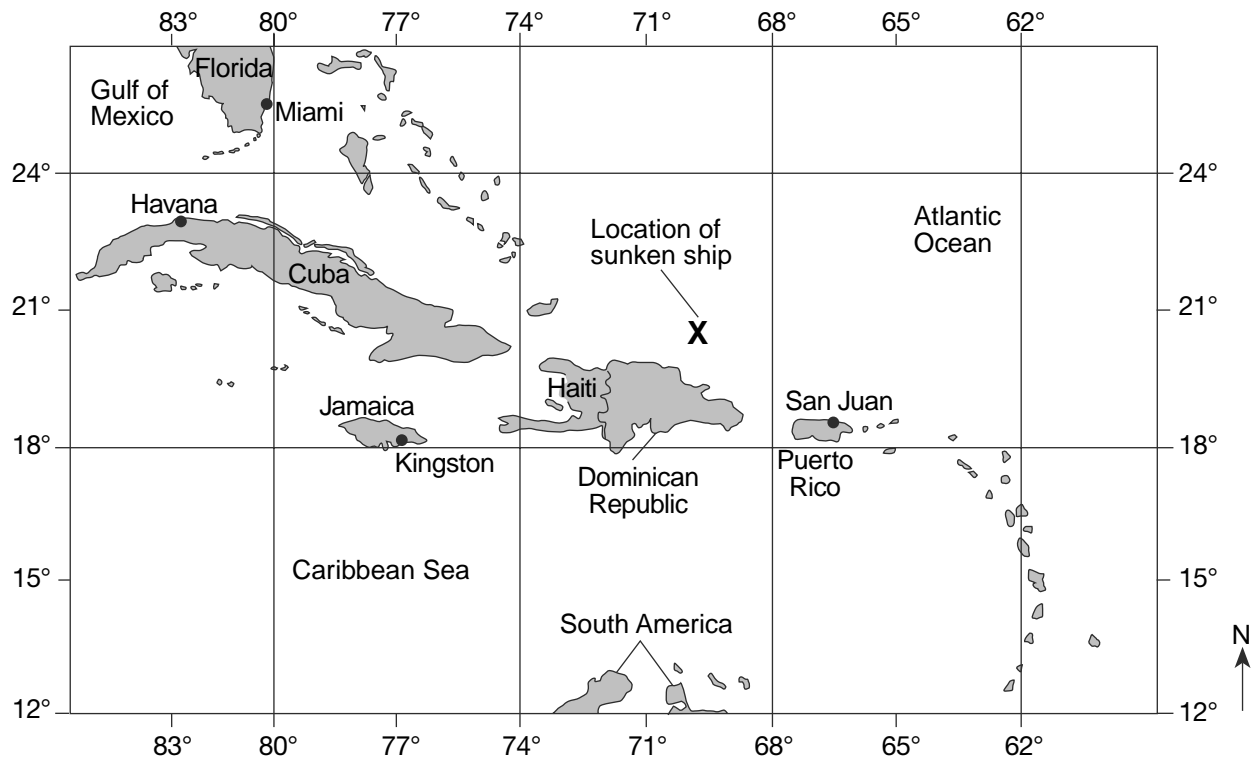

38 The *Concepcion* was carried off course to the northwest by an ocean current flowing from the

- (1) Florida Current
- (2) Gulf Stream Current
- (3) North Atlantic Current
- (4) North Equatorial Current

39 What is the approximate latitude and longitude of the sunken ship?

- (1) 20.5° N 70° E
- (2) 20.5° N 70° W
- (3) 20.5° S 70° E
- (4) 20.5° S 70° W

40 At which map location does *Polaris* appear the highest in the nighttime sky?

- (1) Miami, Florida
- (2) Kingston, Jamaica
- (3) Havana, Cuba
- (4) San Juan, Puerto Rico

41 On which tectonic plate is Puerto Rico located?

- (1) North American Plate
- (2) South American Plate
- (3) Caribbean Plate
- (4) Cocos Plate

Base your answers to questions 42 through 44 on the cross sections below, which represent a particular location of the channel of the San Juan River in Utah. Changes in river discharge (Q), in cubic meters per second, and sediment deposits before, during, and after a flood are shown.

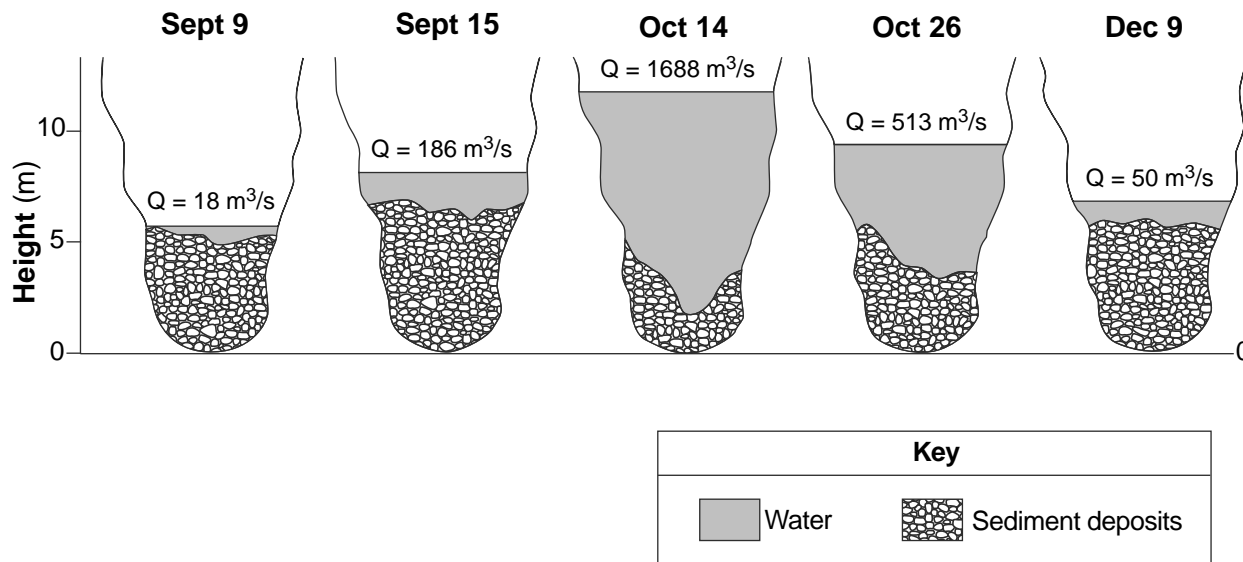

- 42 During the time from September 9 to October 14, the thickness of the sediment deposits at the bottom of the San Juan River's channel
- (1) decreased, only
 (2) increased, only
 (3) decreased and then increased
 (4) increased and then decreased
- 43 On October 14, during the flood, the discharge of the San Juan River changed dramatically. The change in the river's discharge at this location was related to an increase in the river's
- (1) velocity
 (2) gradient
 (3) channel length
 (4) sediment deposits
- 44 If the greatest velocity of the San Juan River on December 9 was 10 centimeters per second, what was the approximate diameter of the largest particles that the river could have carried?
- (1) 1.0 cm
 (2) 2.0 cm
 (3) 10.0 cm
 (4) 0.2 cm

Base your answers to questions 45 through 48 on the map below, which shows the position of the jet stream relative to two air masses and a low-pressure center (**L**) over the United States.

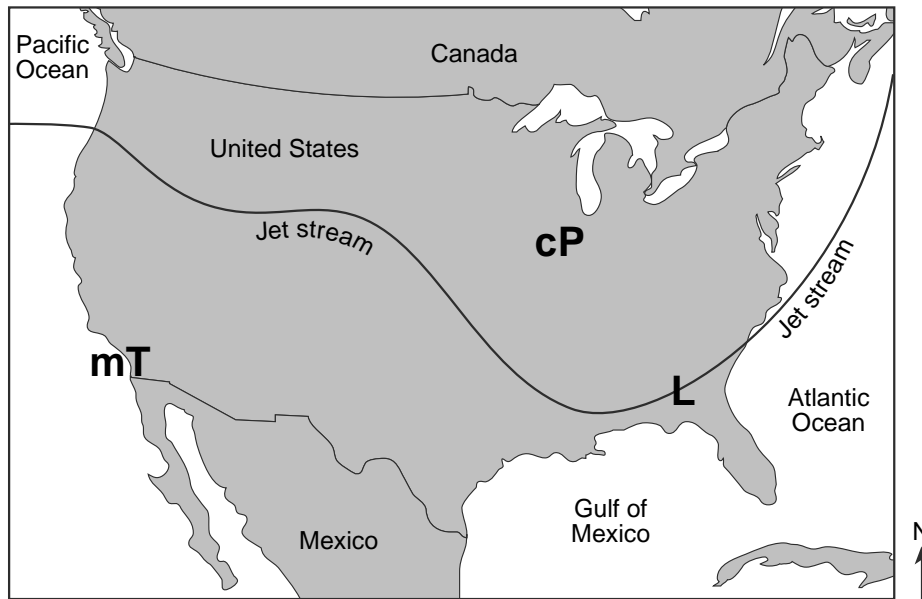

- 45 In which layer of the atmosphere is this jet stream located?
- (1) thermosphere
 - (2) mesosphere
 - (3) stratosphere
 - (4) troposphere
- 46 What is the difference in the air temperature and humidity between the cP and mT air masses?
- (1) The cP air mass is warmer and less humid.
 - (2) The cP air mass is colder and more humid.
 - (3) The mT air mass is warmer and more humid.
 - (4) The mT air mass is colder and less humid.
- 47 What is the general movement of the surface winds around the center of this low-pressure area?
- (1) counterclockwise and outward
 - (2) counterclockwise and inward
 - (3) clockwise and outward
 - (4) clockwise and inward
- 48 Assuming the low-pressure center (**L**) follows a typical storm track, it will move
- (1) into the mT air mass to the west
 - (2) into the cP air mass to the northwest
 - (3) along the path of the jet stream to the northeast
 - (4) along the path of the jet stream to the southwest
-

Base your answers to questions 49 and 50 on the passage and photograph below.

Dinosaur Tracks Revealed After Years of Dry Weather

By April 2005, the surface of Lake Powell, a human-made lake in Utah and Arizona, had fallen 145 feet below its highest level. This revealed many traces of ancient life that had not been observed since this area had been covered with water. Among these traces, discovered in sandstone bedrock, were many dinosaur tracks, ranging in age between 170 and 200 million years old.

Dinosaur Track on Shoreline of Lake Powell

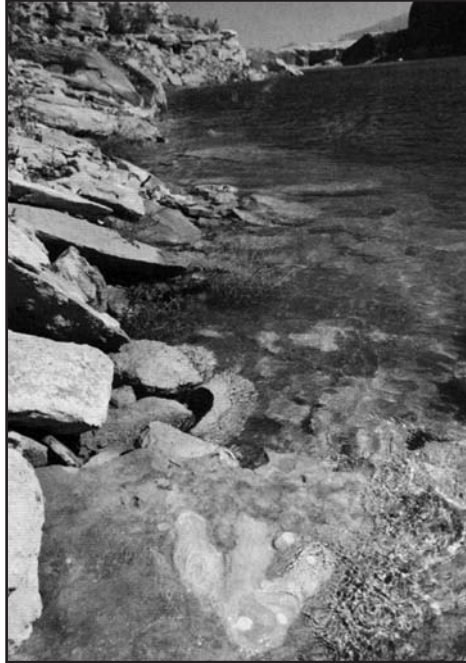

Source: Andre Delgalvis, *Arizona Highways*,
February 2006

49 The events listed below led to the formation and exposure of these dinosaur tracks.

- A. Rock layers above the dinosaur tracks are eroded.
- B. Tracks are made in loose sand by dinosaurs.
- C. Sediments are compressed and cemented.
- D. Sedimentation buries tracks.
- E. The water level of Lake Powell drops.

What is the correct sequence of the events listed above that led to the formation and exposure of the dinosaur tracks in the surface bedrock along the shoreline of Lake Powell?

- (1) $B \rightarrow C \rightarrow A \rightarrow E \rightarrow D$
- (2) $B \rightarrow D \rightarrow C \rightarrow A \rightarrow E$
- (3) $E \rightarrow D \rightarrow A \rightarrow B \rightarrow C$
- (4) $E \rightarrow C \rightarrow B \rightarrow D \rightarrow A$

50 Which conditions before April 2005 in the Lake Powell region most likely produced the *decrease* in the water level of Lake Powell?

- (1) Runoff exceeded precipitation.
- (2) Precipitation exceeded runoff.
- (3) Evaporation exceeded precipitation.
- (4) Precipitation exceeded evaporation.

Part B-2

Answer all questions in this part.

Directions (51–65): Record your answers in the spaces provided in your answer booklet. Some questions may require the use of the *2011 Edition Reference Tables for Physical Setting/Earth Science*.

Base your answers to questions 51 through 53 on the map below, which shows a portion of New York State and Canada. The arrows represent the direction of the wind blowing over Lake Ontario for several days early one winter.

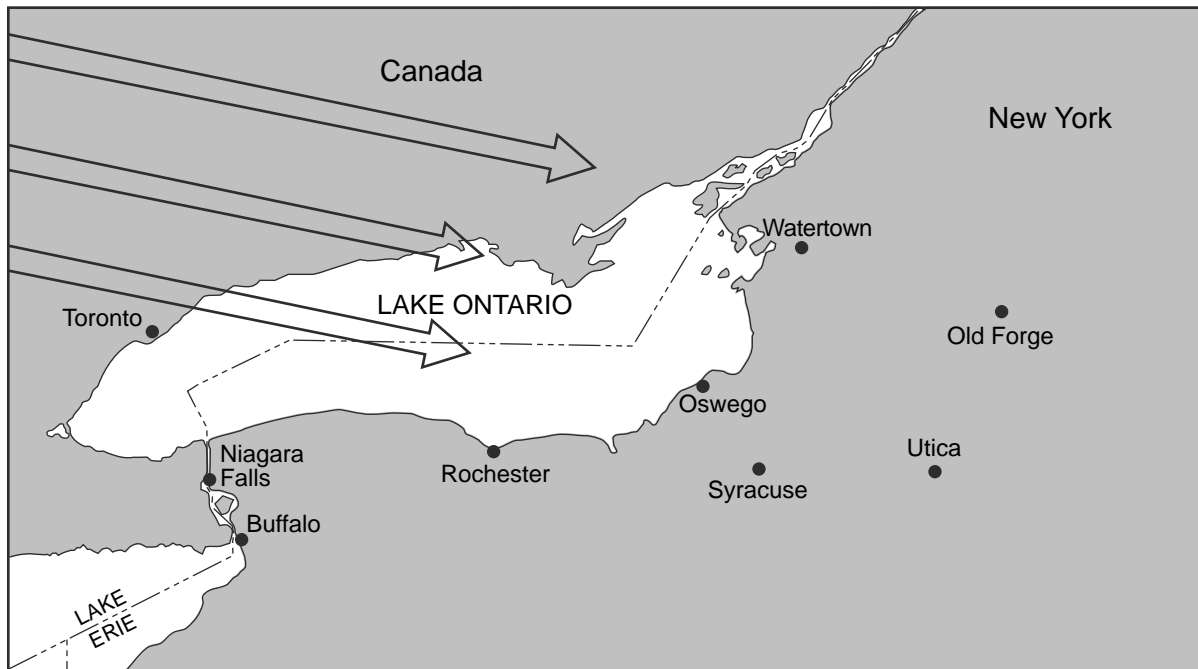

- 51 Explain why Oswego, New York, usually gets more snow than Toronto, Canada, when the wind is blowing in the direction shown on the map. [1]
- 52 Compared to the average winter air temperature in Watertown, New York, explain why the average winter air temperature in Old Forge, New York, is colder. [1]
- 53 Explain why the surface of Lake Erie freezes much later in the winter than the surrounding land surfaces. [1]
-

Base your answers to questions 54 through 57 on the passage below.

Meteorite Composition

Meteors that strike Earth's surface are called meteorites. Analysis of meteorite composition has provided scientists with information regarding the formation of Earth and our solar system, and possibly the development and evolution of life on Earth.

Two types of meteorites are iron meteorites and chondrites. Iron meteorites consist mostly of iron and nickel, and are inferred to be from core materials of early planetary bodies in our solar system. More than 60% of meteorites studied have been identified as chondrites. Chondrites are made of millimeter-sized spheres of olivine and pyroxene crystals embedded in a mass of mineral and metal grains. The chondrites are thought to represent fragments of the earliest solid materials in our solar system. One type of chondrite, the carbonaceous chondrite, contains water, organic compounds, and minerals that represent the chemical composition necessary for life to form.

- 54 Identify the type of meteorite that is inferred to have a composition similar to the composition of Earth's core. [1]
- 55 Identify *two* elements that can be found in *both* olivine and pyroxene. [1]
- 56 What is the estimated age, in years, of Earth and our solar system? [1]
- 57 Explain why there is little evidence of meteorite impact craters on Earth. [1]
-

Base your answers to questions 58 through 61 on the generalized map below, which shows a portion of the Atlantic Ocean floor located between South America and Africa. Isolines show the approximate age, in million years, of the ocean-floor bedrock on each side of the Mid-Atlantic Ridge. Points A, B, and X represent locations on the ocean floor.

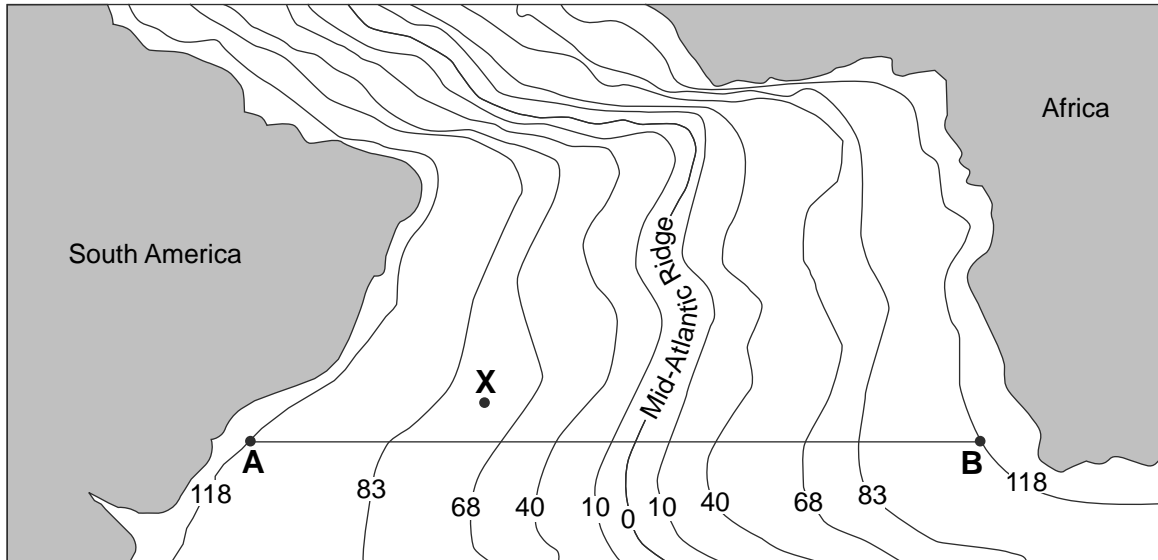

- 58 On the grid in your answer booklet, construct a line graph of bedrock age by plotting the age of the bedrock shown by each isoline that crosses line AB. Points A and B are plotted on the grid. Connect the plots from A to B with a line. [1]
- 59 Estimate the age of the ocean-floor bedrock at point X. [1]
- 60 Explain why the age of the ocean-floor bedrock increases as the distance from the Mid-Atlantic Ridge increases. [1]
- 61 The Mid-Atlantic Ridge separates pairs of crustal plates, such as the South American Plate and the African Plate. Identify one other pair of crustal plates separated by the Mid-Atlantic Ridge. [1]
-

Base your answers to questions 62 through 65 on the topographic map in your answer booklet. Letters *A* through *D* represent locations on the map. Elevations are measured in feet. Dashed lines represent trails.

62 On the map *in your answer booklet*, place an **X** on the trail between *A* and *B* so the center of the **X** indicates where the slope is steepest. [1]

63 On the map *in your answer booklet*, first draw an arrow on the stream to show the direction in which the stream is flowing. Then state *one* piece of evidence shown on the map that supports the direction of the arrow you drew on the stream. [1]

64 Identify the contour interval used on this map. [1]

65 How long will it take a person to hike along the trail from point *C* to point *D* at a rate of 3 miles per hour? [1]

Part C

Answer all questions in this part.

Directions (66–85): Record your answers in the spaces provided in your answer booklet. Some questions may require the use of the *2011 Edition Reference Tables for Physical Setting/Earth Science*.

Base your answers to questions 66 through 68 on the bar graph below and on the data table in your answer booklet. The bar graph shows the number of partial lunar eclipses that occurred during each of the last nine centuries (100-year intervals) on Earth. A partial lunar eclipse occurs when only part of the Moon is within the darkest part of Earth's shadow. The data table in your answer booklet shows the number of total lunar eclipses that occurred during the same nine centuries. A total lunar eclipse occurs when the entire Moon is completely within the darkest part of Earth's shadow.

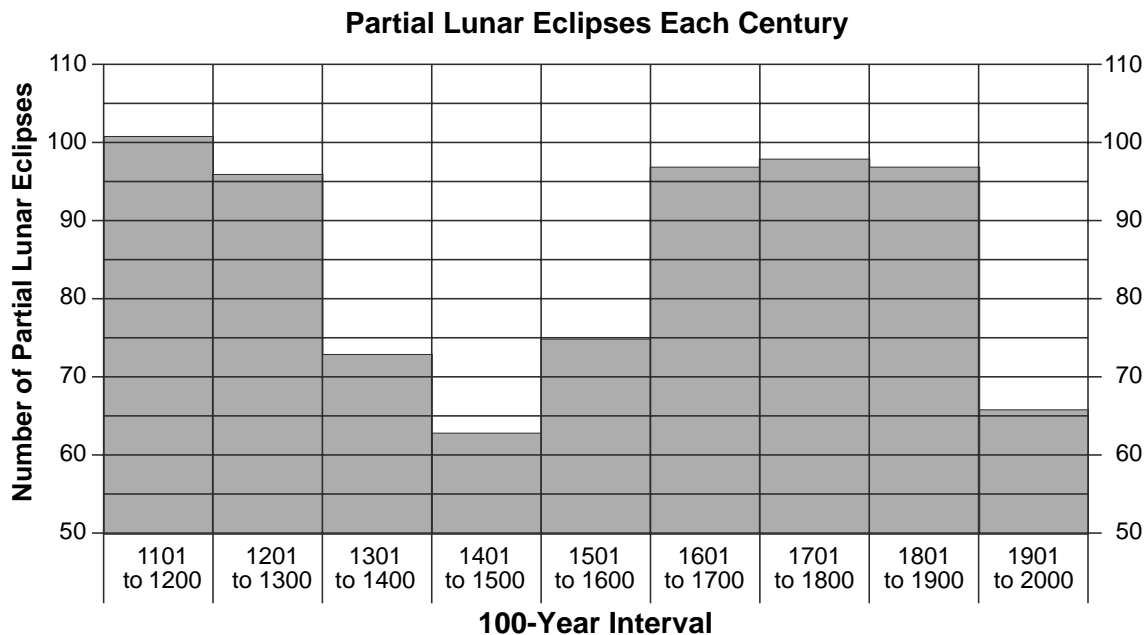

- 66 On the grid *in your answer booklet*, construct a bar graph of the number of total lunar eclipses for *each* 100-year interval listed on the data table in your answer booklet. [1]
- 67 State the relationship between the number of partial lunar eclipses per century and the number of total lunar eclipses per century. [1]
- 68 On the diagram *in your answer booklet*, draw an **X** so the center of the **X** indicates the position of Earth during a lunar eclipse. [1]
-

Base your answers to questions 69 through 74 on the geologic cross section below, which shows rock units 1 through 7 that have *not* been overturned. Some of the rock units contain New York State index fossils. An unconformity exists between rock units 5 and 6.

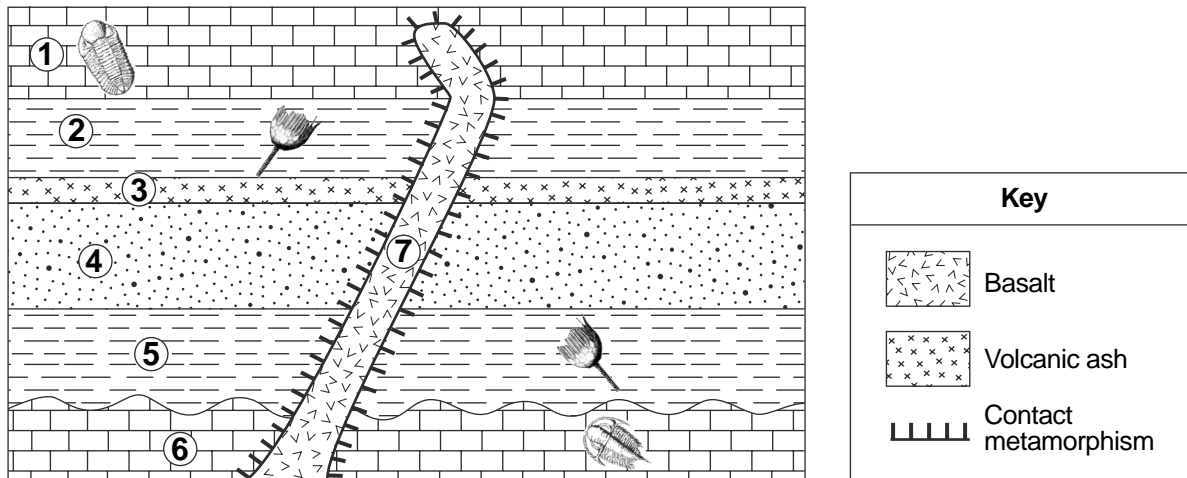

- 69 State the grain size of the sediment that was deposited to form rock unit 2. [1]
- 70 Identify *two* processes that produced the basalt. [1]
- 71 What evidence shown in the cross section indicates that the basalt rock unit is the youngest rock unit? [1]
- 72 Bedrock from which entire geologic time period is missing between rock units 5 and 6? [1]
- 73 Identify *one* metamorphic rock that could have been formed by the contact metamorphism within rock unit 1. [1]
- 74 Describe *one* characteristic of volcanic ash layers and index fossils that makes *both* of them good geologic time markers. [1]
-

Base your answers to questions 75 through 78 on the map in your answer booklet, which shows surface air temperatures, in degrees Fahrenheit, for a portion of the United States. These temperatures were recorded at noontime on the same winter day. Two coastal cities are labeled: Atlantic City, New Jersey, and Miami, Florida. Other selected locations are labeled A, B, and C.

- 75 On the map *in your answer booklet*, draw the 60°F isotherm from location A to the western edge of the map. [1]
- 76 Calculate the temperature gradient between locations B and C in °F per mile. [1]
- 77 Explain why the noontime winter air temperatures in Miami, Florida, are usually higher than the noontime winter air temperatures in Atlantic City, New Jersey. [1]
- 78 A frontal boundary exists between locations B and C. Identify *one* process that causes clouds to form in the moist air rising along this frontal boundary. [1]
-

Base your answers to questions 79 and 80 on the climate graph below, which shows the average monthly precipitation and average monthly air temperatures at city X. City X is located near a mountain range in the Southern Hemisphere.

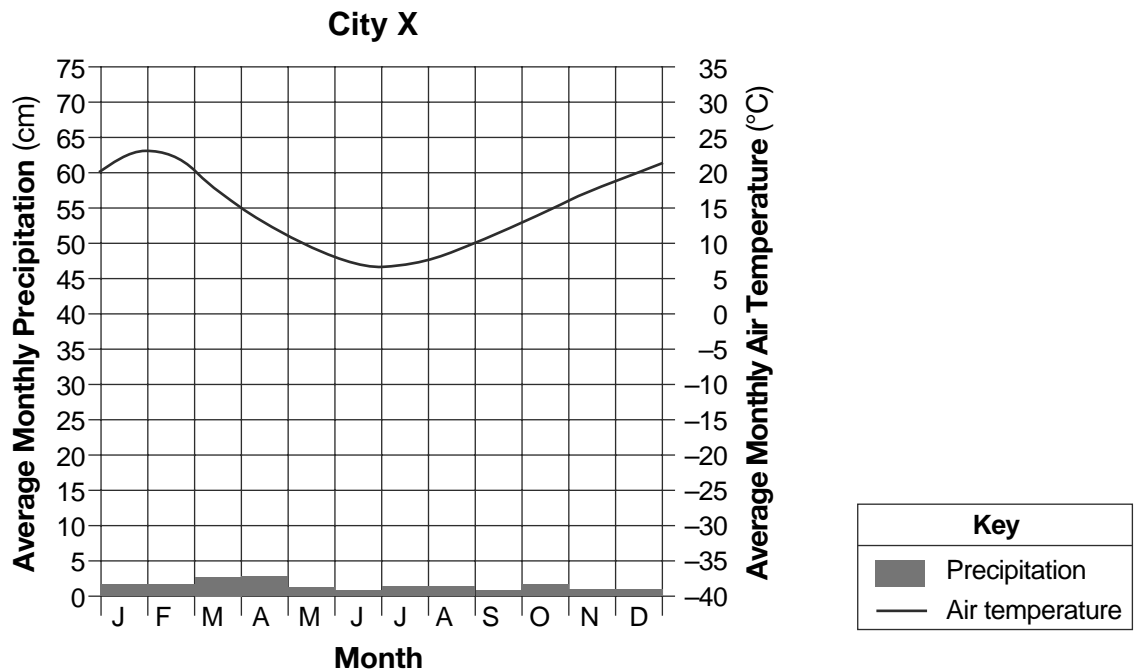

- 79 What evidence shown on the graph indicates that city X is located in the Southern Hemisphere? [1]
- 80 *In your answer booklet*, state whether the climate of city X is dry or wet. Then, on the cross section *in your answer booklet*, place an **X** on Earth's surface to indicate the most likely location of city X. [1]
-

Base your answers to questions 81 through 85 on the diagram in your answer booklet. The diagram shows Earth revolving around the Sun. Letters *A*, *B*, *C*, and *D* represent Earth's location in its orbit on the first day of the four seasons. Aphelion (farthest distance from the Sun) and perihelion (closest distance to the Sun) are labeled to show the approximate times when they occur in Earth's orbit.

- 81 On the diagram *in your answer booklet*, draw a line through Earth at location *A* to represent Earth's tilted axis on the first day of summer in the Northern Hemisphere. Label the North Pole end of the axis. [1]
- 82 On the diagram *in your answer booklet*, draw an arrow on Earth at location *D* to show the direction of Earth's rotation. Extend the arrow from one side of Earth to the other side of Earth. [1]
- 83 Approximately how many days does it take Earth to travel from location *B* to location *C*? [1]
- 84 Explain why the gravitational attraction between the Sun and Earth *decreases* as Earth travels from location *D* to location *A*. [1]
- 85 Explain why an observer in New York State sees some different constellations in the night sky when Earth is at location *A* compared to when Earth is at location *C*. [1]
-

