

The University of the State of New York
REGENTS HIGH SCHOOL EXAMINATION

GEOMETRY

Wednesday, June 20, 2012 — 9:15 a.m. to 12:15 p.m., only

Student Name: _____

School Name: _____

Print your name and the name of your school on the lines above.

A separate answer sheet for Part I has been provided to you. Follow the instructions from the proctor for completing the student information on your answer sheet.

This examination has four parts, with a total of 38 questions. You must answer all questions in this examination. Write your answers to the Part I multiple-choice questions on the separate answer sheet. Write your answers to the questions in Parts II, III, and IV directly in this booklet. All work should be written in pen, except for graphs and drawings, which should be done in pencil. Clearly indicate the necessary steps, including appropriate formula substitutions, diagrams, graphs, charts, etc.

The formulas that you may need to answer some questions in this examination are found at the end of the examination. This sheet is perforated so you may remove it from this booklet.

Scrap paper is not permitted for any part of this examination, but you may use the blank spaces in this booklet as scrap paper. A perforated sheet of scrap graph paper is provided at the end of this booklet for any question for which graphing may be helpful but is not required. You may remove this sheet from this booklet. Any work done on this sheet of scrap graph paper will *not* be scored.

When you have completed the examination, you must sign the statement printed at the end of the answer sheet, indicating that you had no unlawful knowledge of the questions or answers prior to the examination and that you have neither given nor received assistance in answering any of the questions during the examination. Your answer sheet cannot be accepted if you fail to sign this declaration.

Notice...

A graphing calculator, a straightedge (ruler), and a compass must be available for you to use while taking this examination.

The use of any communications device is strictly prohibited when taking this examination. If you use any communications device, no matter how briefly, your examination will be invalidated and no score will be calculated for you.

DO NOT OPEN THIS EXAMINATION BOOKLET UNTIL THE SIGNAL IS GIVEN.

Part I

Answer all 28 questions in this part. Each correct answer will receive 2 credits. No partial credit will be allowed. For each question, write on the separate answer sheet the numeral preceding the word or expression that best completes the statement or answers the question. [56]

Use this space for computations.

1 Triangle ABC is graphed on the set of axes below.

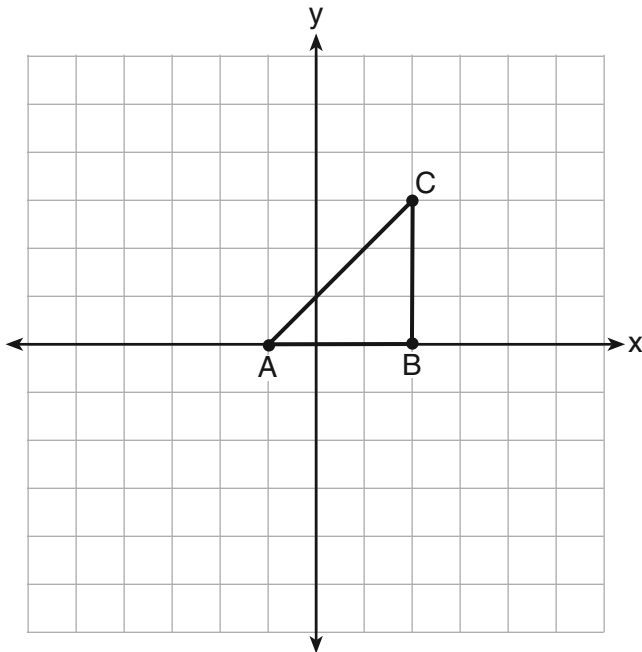

Which transformation produces an image that is similar to, but *not* congruent to, $\triangle ABC$?

- (1) $T_{2,3}$
- (2) D_2
- (3) $r_{y=x}$
- (4) R_{90}

2 A student wrote the sentence “4 is an odd integer.” What is the negation of this sentence and the truth value of the negation?

- (1) 3 is an odd integer; true
- (2) 4 is not an odd integer; true
- (3) 4 is not an even integer; false
- (4) 4 is an even integer; false

Use this space for computations.

3 As shown in the diagram below, \overleftrightarrow{EF} intersects planes \mathcal{P} , Q , and \mathcal{R} .

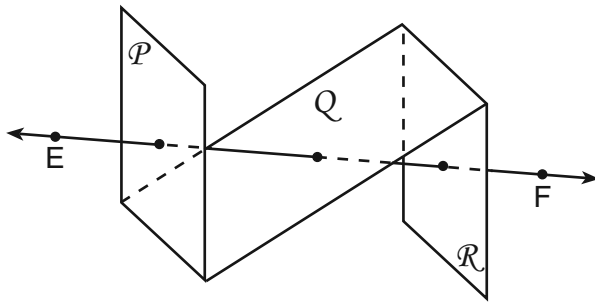

If \overleftrightarrow{EF} is perpendicular to planes \mathcal{P} and \mathcal{R} , which statement must be true?

- (1) Plane \mathcal{P} is perpendicular to plane Q .
- (2) Plane \mathcal{R} is perpendicular to plane \mathcal{P} .
- (3) Plane \mathcal{P} is parallel to plane Q .
- (4) Plane \mathcal{R} is parallel to plane \mathcal{P} .

4 In the diagram below, $LATE$ is an isosceles trapezoid with $\overline{LE} \cong \overline{AT}$, $LA = 24$, $ET = 40$, and $AT = 10$. Altitudes \overline{LF} and \overline{AG} are drawn.

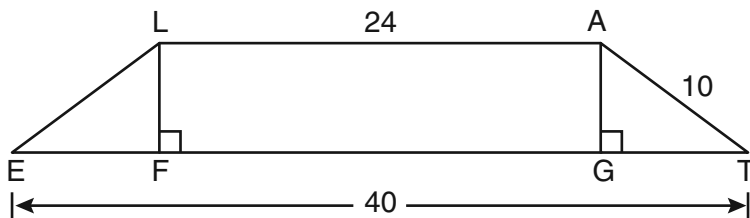

What is the length of \overline{LF} ?

- (1) 6
- (2) 8
- (3) 3
- (4) 4

Use this space for computations.

5 In the diagram below of circle O , diameter \overline{AB} is parallel to chord \overline{CD} .

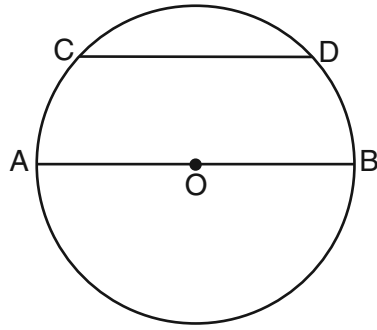

If $m\widehat{CD} = 70$, what is $m\widehat{AC}$?

- (1) 110 (3) 55
(2) 70 (4) 35

6 In the diagram below of \overline{ABCD} , $\overline{AC} \cong \overline{BD}$.

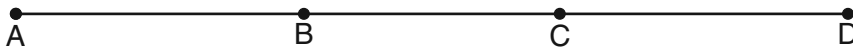

Using this information, it could be proven that

- (1) $BC = AB$ (3) $AD - BC = CD$
(2) $AB = CD$ (4) $AB + CD = AD$

7 The diameter of a sphere is 15 inches. What is the volume of the sphere, to the nearest tenth of a cubic inch?

- (1) 706.9 (3) 2827.4
(2) 1767.1 (4) 14,137.2

Use this space for
computations.

- 8 The diagram below shows the construction of \overleftrightarrow{AB} through point P parallel to \overleftrightarrow{CD} .

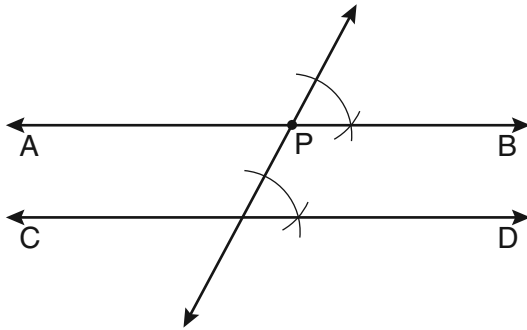

Which theorem justifies this method of construction?

- (1) If two lines in a plane are perpendicular to a transversal at different points, then the lines are parallel.
 - (2) If two lines in a plane are cut by a transversal to form congruent corresponding angles, then the lines are parallel.
 - (3) If two lines in a plane are cut by a transversal to form congruent alternate interior angles, then the lines are parallel.
 - (4) If two lines in a plane are cut by a transversal to form congruent alternate exterior angles, then the lines are parallel.
- 9 Parallelogram $ABCD$ has coordinates $A(1,5)$, $B(6,3)$, $C(3,-1)$, and $D(-2,1)$. What are the coordinates of E , the intersection of diagonals \overline{AC} and \overline{BD} ?
- (1) $(2,2)$
 - (2) $(4.5,1)$
 - (3) $(3.5,2)$
 - (4) $(-1,3)$
- 10 What is the equation of a circle whose center is 4 units above the origin in the coordinate plane and whose radius is 6?
- (1) $x^2 + (y - 6)^2 = 16$
 - (2) $(x - 6)^2 + y^2 = 16$
 - (3) $x^2 + (y - 4)^2 = 36$
 - (4) $(x - 4)^2 + y^2 = 36$

Use this space for
computations.

- 11 In the diagram of $\triangle ABC$ shown below, D is the midpoint of \overline{AB} , E is the midpoint of \overline{BC} , and F is the midpoint of \overline{AC} .

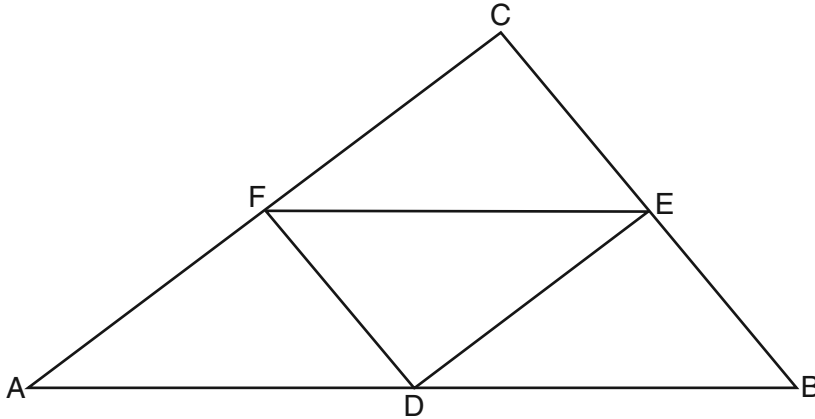

If $AB = 20$, $BC = 12$, and $AC = 16$, what is the perimeter of trapezoid $ABEF$?

- (1) 24
(2) 36
(3) 40
(4) 44
- 12 In the diagram below, $\triangle LMO$ is isosceles with $LO = MO$.

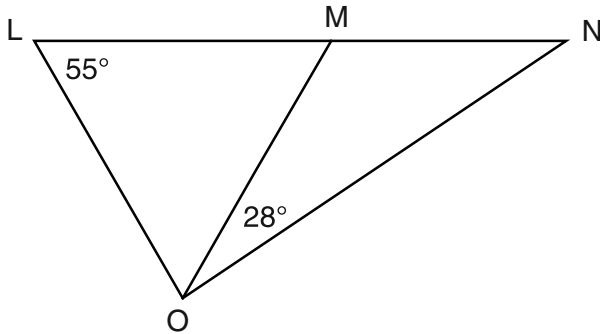

If $m\angle L = 55$ and $m\angle NOM = 28$, what is $m\angle N$?

- (1) 27
(2) 28
(3) 42
(4) 70

Use this space for
computations.

13 If \overleftrightarrow{AB} is contained in plane \mathcal{P} , and \overleftrightarrow{AB} is perpendicular to plane \mathcal{R} , which statement is true?

- (1) \overleftrightarrow{AB} is parallel to plane \mathcal{R} .
- (2) Plane \mathcal{P} is parallel to plane \mathcal{R} .
- (3) \overleftrightarrow{AB} is perpendicular to plane \mathcal{P} .
- (4) Plane \mathcal{P} is perpendicular to plane \mathcal{R} .

14 In the diagram below of $\triangle ABC$, $\overline{AE} \cong \overline{BE}$, $\overline{AF} \cong \overline{CF}$, and $\overline{CD} \cong \overline{BD}$.

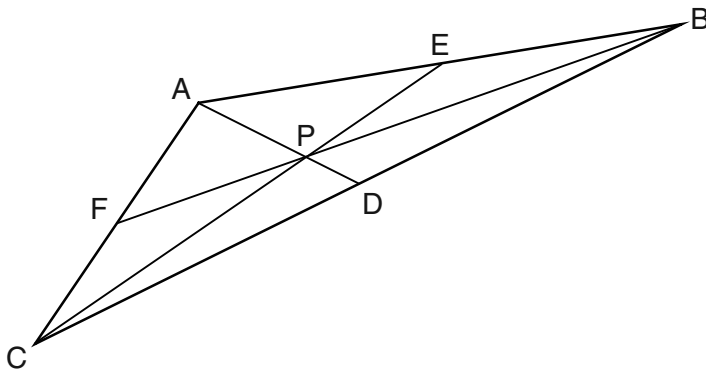

Point P must be the

- | | |
|------------------|-----------------|
| (1) centroid | (3) incenter |
| (2) circumcenter | (4) orthocenter |

15 What is the equation of the line that passes through the point $(-9,6)$ and is perpendicular to the line $y = 3x - 5$?

- | | |
|-----------------------------|-----------------------------|
| (1) $y = 3x + 21$ | (3) $y = 3x + 33$ |
| (2) $y = -\frac{1}{3}x - 3$ | (4) $y = -\frac{1}{3}x + 3$ |

Use this space for
computations.

16 In the diagram of $\triangle ABC$ shown below, $\overline{DE} \parallel \overline{BC}$.

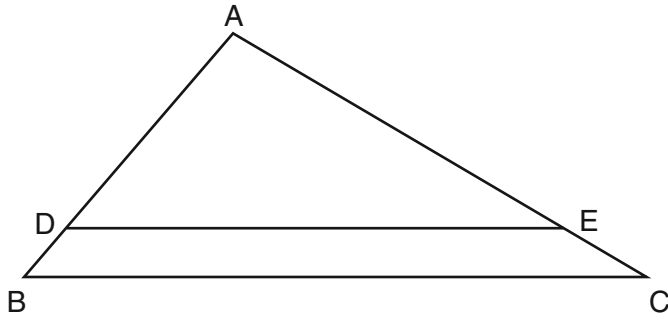

If $AB = 10$, $AD = 8$, and $AE = 12$, what is the length of \overline{EC} ?

- (1) 6
(2) 2
(3) 3
(4) 15

17 What is the length of \overline{AB} with endpoints $A(-1,0)$ and $B(4,-3)$?

- (1) $\sqrt{6}$
(2) $\sqrt{18}$
(3) $\sqrt{34}$
(4) $\sqrt{50}$

18 The sum of the interior angles of a polygon of n sides is

- (1) 360
(2) $\frac{360}{n}$
(3) $(n - 2) \cdot 180$
(4) $\frac{(n - 2) \cdot 180}{n}$

Use this space for computations.

19 What is the slope of a line perpendicular to the line whose equation is $20x - 2y = 6$?

(1) -10

(3) 10

(2) $-\frac{1}{10}$

(4) $\frac{1}{10}$

20 Which graph represents a circle whose equation is $(x + 2)^2 + y^2 = 16$?

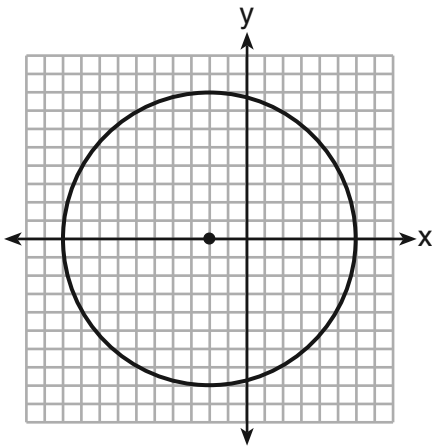

(1)

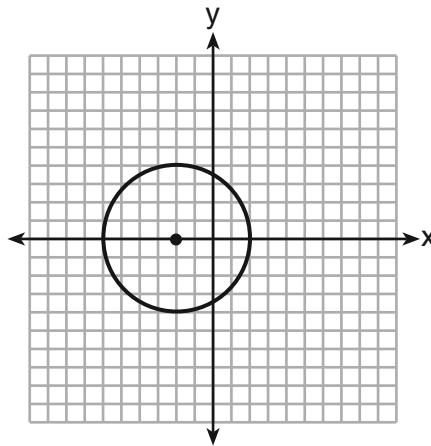

(3)

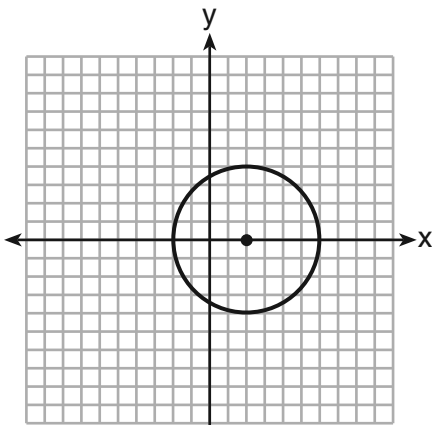

(2)

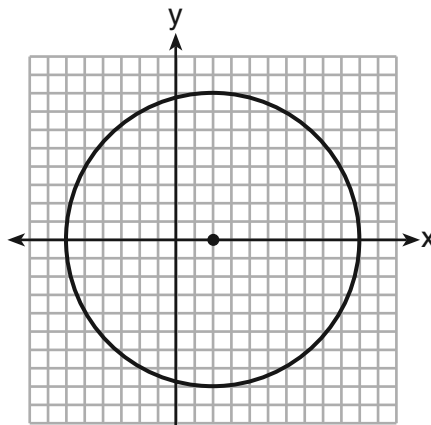

(4)

Use this space for computations.

- 21 In circle O shown below, diameter \overline{DB} is perpendicular to chord \overline{AC} at E .

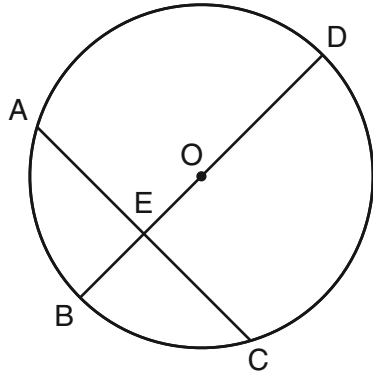

If $DB = 34$, $AC = 30$, and $DE > BE$, what is the length of \overline{BE} ?

- (1) 8
(2) 9
(3) 16
(4) 25
- 22 In parallelogram $ABCD$ shown below, diagonals \overline{AC} and \overline{BD} intersect at E .

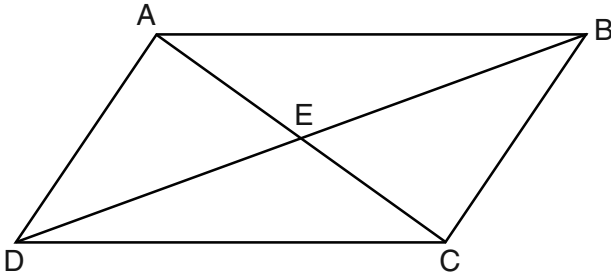

Which statement must be true?

- (1) $\overline{AC} \cong \overline{DB}$
(2) $\angle ABD \cong \angle CBD$
(3) $\triangle AED \cong \triangle CEB$
(4) $\triangle DCE \cong \triangle BCE$

Use this space for
computations.

23 Which equation of a circle will have a graph that lies entirely in the first quadrant?

- (1) $(x - 4)^2 + (y - 5)^2 = 9$ (3) $(x + 4)^2 + (y + 5)^2 = 25$
(2) $(x + 4)^2 + (y + 5)^2 = 9$ (4) $(x - 5)^2 + (y - 4)^2 = 25$

24 In the diagram below, $\triangle ABC \sim \triangle RST$.

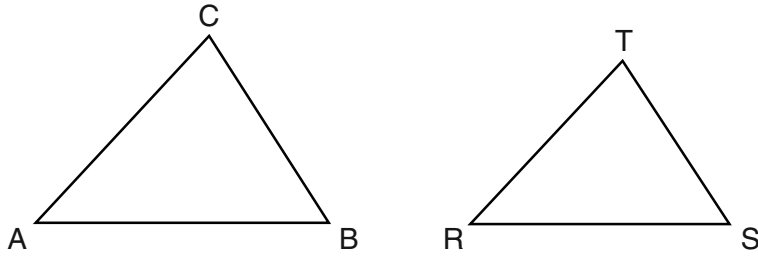

Which statement is *not* true?

- (1) $\angle A \cong \angle R$ (3) $\frac{AB}{BC} = \frac{ST}{RS}$
(2) $\frac{AB}{RS} = \frac{BC}{ST}$ (4) $\frac{AB + BC + AC}{RS + ST + RT} = \frac{AB}{RS}$

Use this space for computations.

25 In the diagram below of $\triangle ABC$, \overline{BC} is extended to D .

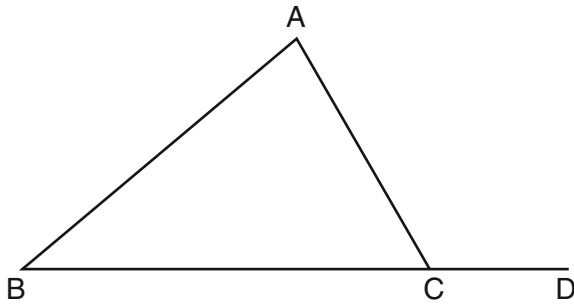

(Not drawn to scale)

If $m\angle A = x^2 - 6x$, $m\angle B = 2x - 3$, and $m\angle ACD = 9x + 27$, what is the value of x ?

- (1) 10 (3) 3
(2) 2 (4) 15

26 An equation of the line that passes through $(2, -1)$ and is parallel to the line $2y + 3x = 8$ is

- (1) $y = \frac{3}{2}x - 4$ (3) $y = -\frac{3}{2}x - 2$
(2) $y = \frac{3}{2}x + 4$ (4) $y = -\frac{3}{2}x + 2$

27 The graph below shows \overline{JT} and its image, $\overline{J'T'}$, after a transformation.

Use this space for computations.

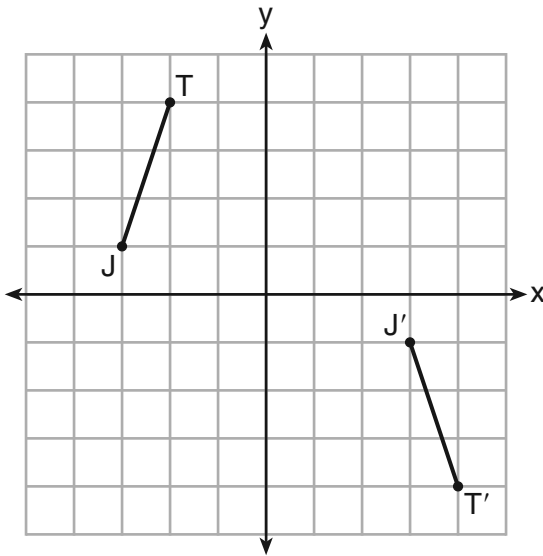

Which transformation would map \overline{JT} onto $\overline{J'T'}$?

- (1) translation
- (2) glide reflection
- (3) rotation centered at the origin
- (4) reflection through the origin

28 Which reason could be used to prove that a parallelogram is a rhombus?

- (1) Diagonals are congruent.
 - (2) Opposite sides are parallel.
 - (3) Diagonals are perpendicular.
 - (4) Opposite angles are congruent.
-

Part II

Answer all 6 questions in this part. Each correct answer will receive 2 credits. Clearly indicate the necessary steps, including appropriate formula substitutions, diagrams, graphs, charts, etc. For all questions in this part, a correct numerical answer with no work shown will receive only 1 credit. All answers should be written in pen, except for graphs and drawings, which should be done in pencil. [12]

29 Triangle TAP has coordinates $T(-1,4)$, $A(2,4)$, and $P(2,0)$.

On the set of axes below, graph and label $\triangle T'A'P'$, the image of $\triangle TAP$ after the translation $(x,y) \rightarrow (x - 5, y - 1)$.

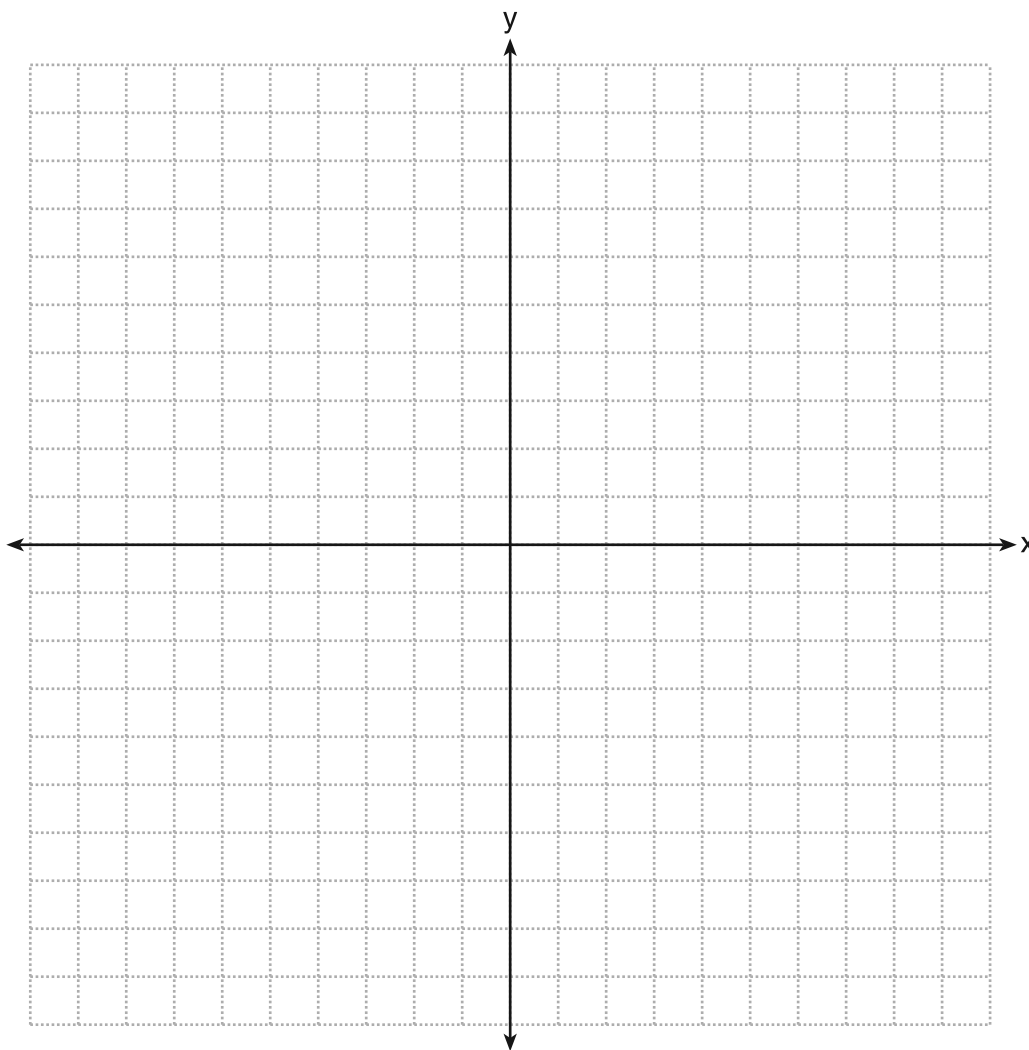

30 In the diagram below, $\ell \parallel m$ and $\overline{QR} \perp \overline{ST}$ at R .

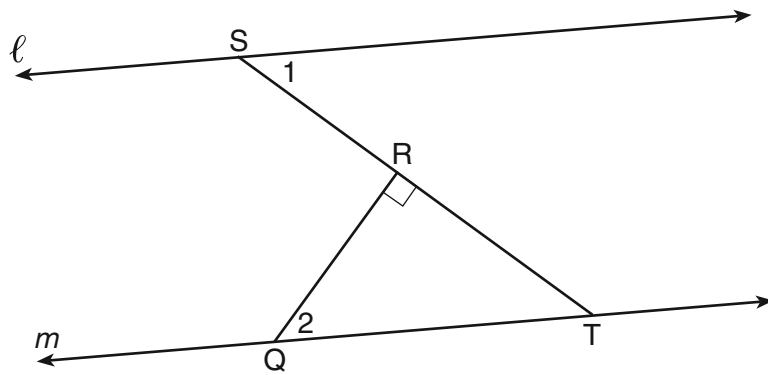

If $m\angle 1 = 63$, find $m\angle 2$.

31 Two lines are represented by the equations $x + 2y = 4$ and $4y - 2x = 12$. Determine whether these lines are parallel, perpendicular, or neither. Justify your answer.

32 Using a compass and straightedge, construct the bisector of $\angle CBA$.
[Leave all construction marks.]

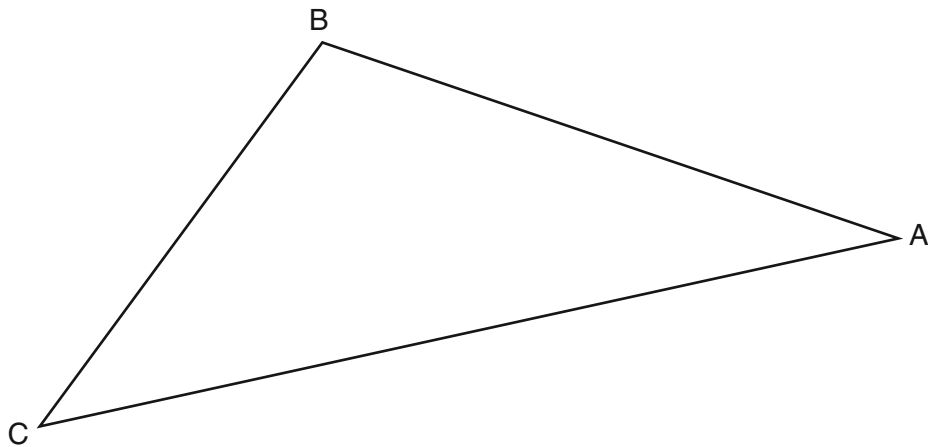

33 The cylindrical tank shown in the diagram below is to be painted. The tank is open at the top, and the bottom does *not* need to be painted. Only the outside needs to be painted. Each can of paint covers 600 square feet. How many cans of paint must be purchased to complete the job?

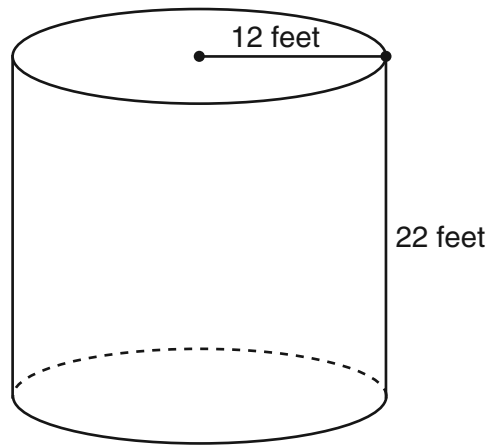

34 On the set of axes below, graph the locus of points that are 4 units from the line $x = 3$ and the locus of points that are 5 units from the point $(0,2)$. Label with an **X** *all* points that satisfy *both* conditions.

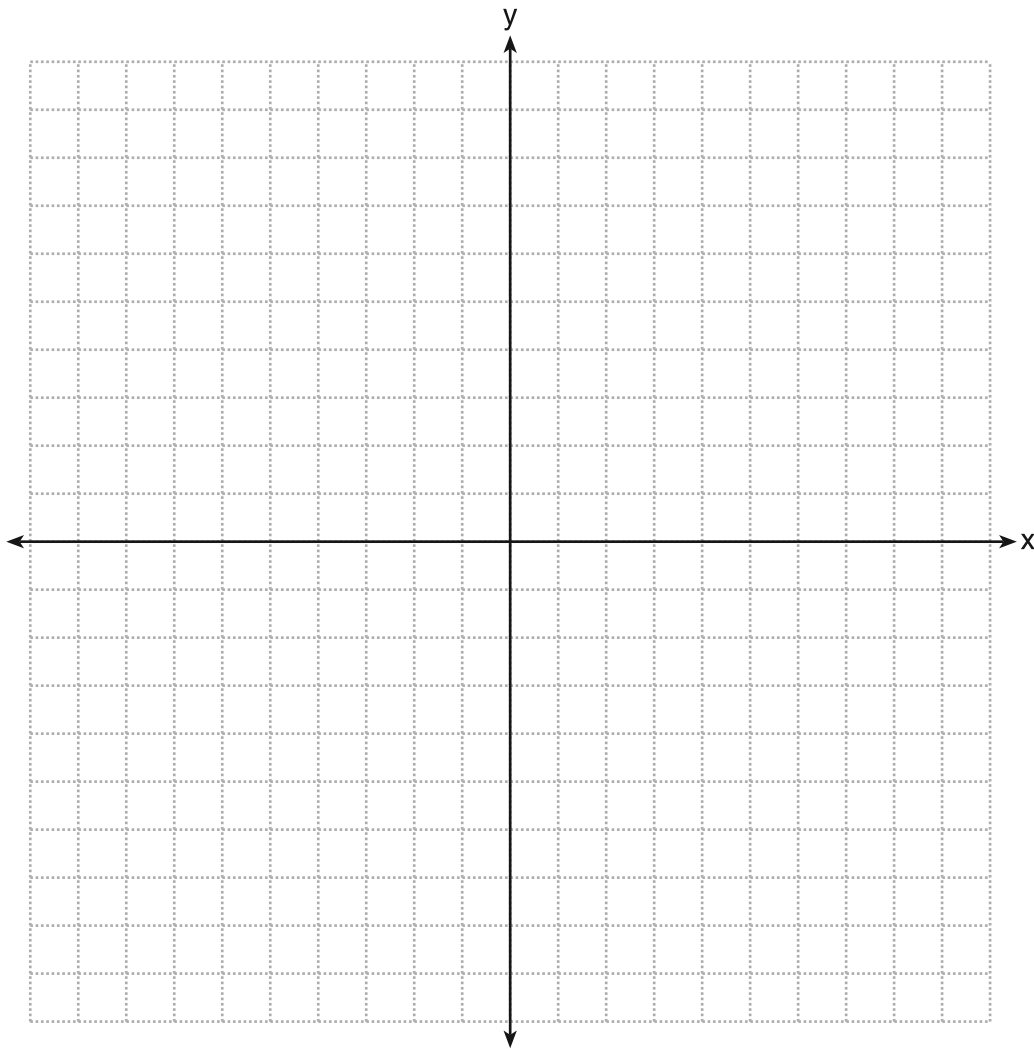

Part III

Answer all 3 questions in this part. Each correct answer will receive 4 credits. Clearly indicate the necessary steps, including appropriate formula substitutions, diagrams, graphs, charts, etc. For all questions in this part, a correct numerical answer with no work shown will receive only 1 credit. All answers should be written in pen, except for graphs and drawings, which should be done in pencil. [12]

35 Given: \overline{AD} bisects \overline{BC} at E .

$$\overline{AB} \perp \overline{BC}$$

$$\overline{DC} \perp \overline{BC}$$

Prove: $\overline{AB} \cong \overline{DC}$

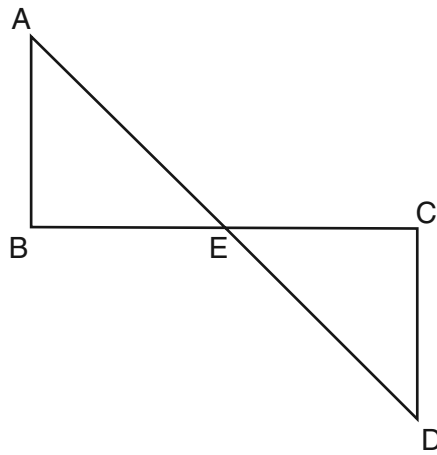

- 36** The coordinates of trapezoid $ABCD$ are $A(-4,5)$, $B(1,5)$, $C(1,2)$, and $D(-6,2)$. Trapezoid $A''B''C''D''$ is the image after the composition $r_{x\text{-axis}} \circ r_{y=x}$ is performed on trapezoid $ABCD$. State the coordinates of trapezoid $A''B''C''D''$.
[The use of the set of axes below is optional.]

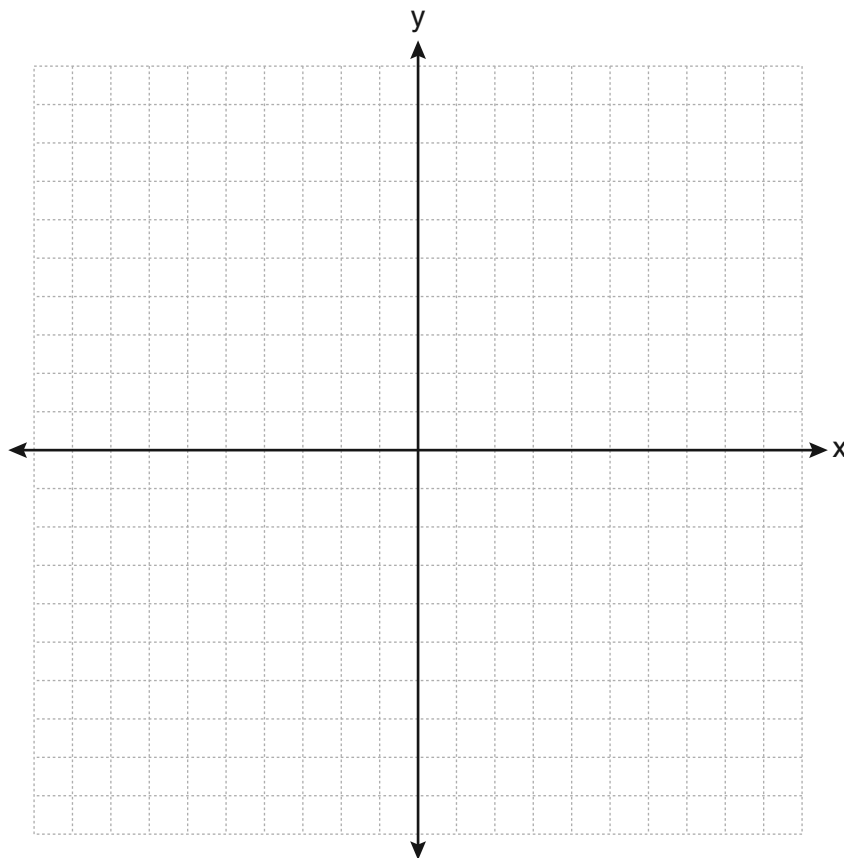

37 In the diagram below of circle O , chords \overline{RT} and \overline{QS} intersect at M . Secant \overline{PTR} and tangent \overline{PS} are drawn to circle O . The length of \overline{RM} is two more than the length of \overline{TM} , $QM = 2$, $SM = 12$, and $PT = 8$.

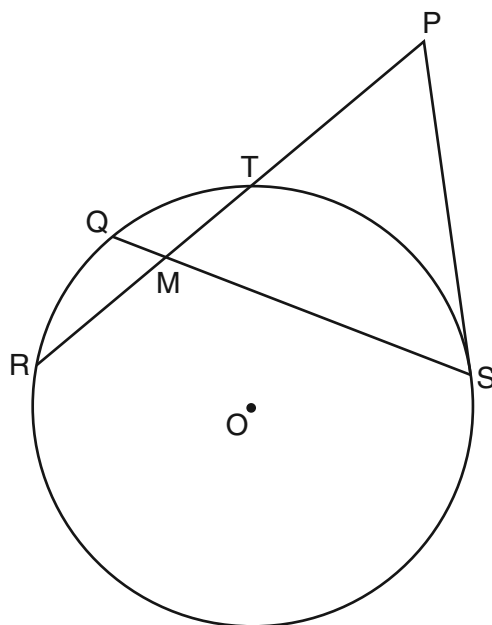

Find the length of \overline{RT} .

Find the length of \overline{PS} .

Part IV

Answer the question in this part. A correct answer will receive 6 credits. Clearly indicate the necessary steps, including appropriate formula substitutions, diagrams, graphs, charts, etc. A correct numerical answer with no work shown will receive only 1 credit. The answer should be written in pen, except for graphs and drawings, which should be done in pencil. [6]

38 On the set of axes below, solve the system of equations graphically and state the coordinates of all points in the solution.

$$y = (x - 2)^2 - 3$$

$$2y + 16 = 4x$$

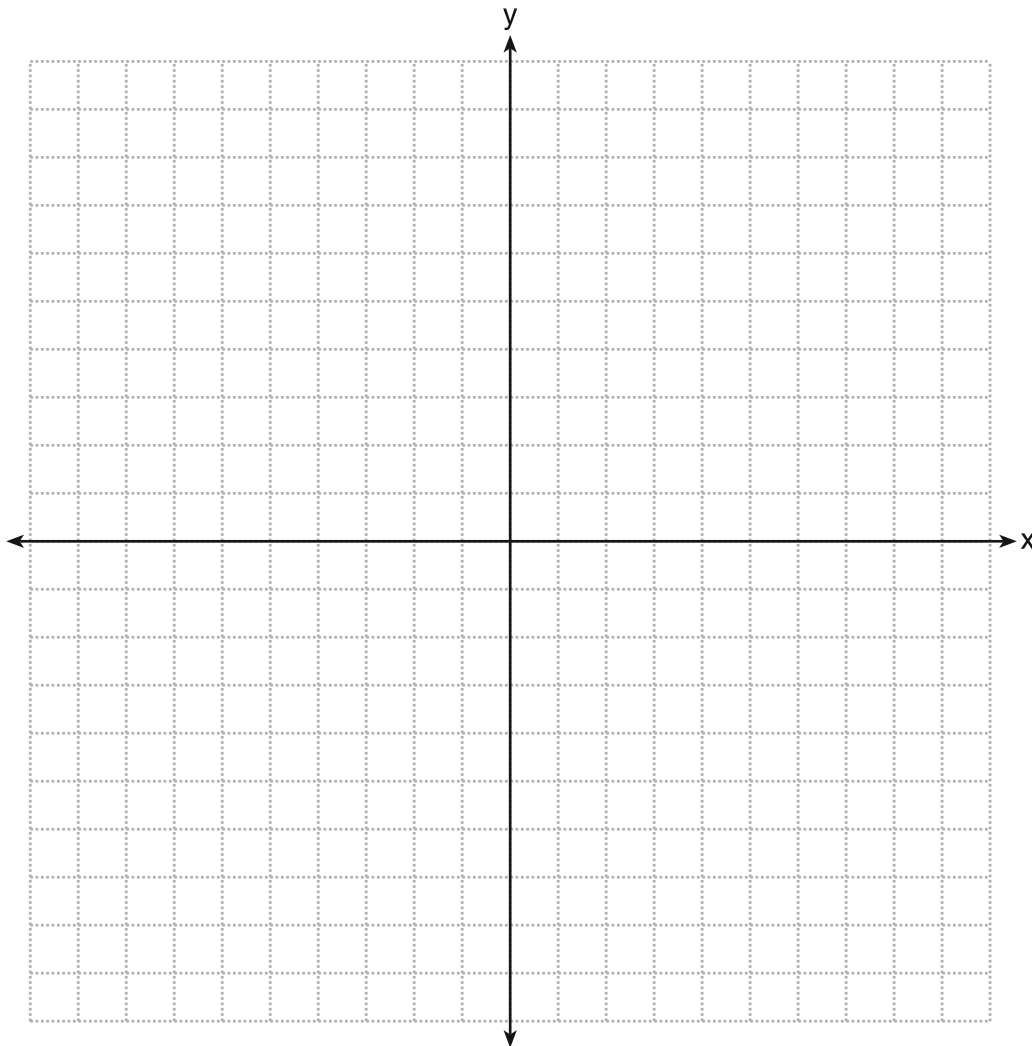

Reference Sheet

Tear Here

Volume	Cylinder	$V = Bh$ where B is the area of the base
	Pyramid	$V = \frac{1}{3}Bh$ where B is the area of the base
	Right Circular Cone	$V = \frac{1}{3}Bh$ where B is the area of the base
	Sphere	$V = \frac{4}{3}\pi r^3$

Lateral Area (L)	Right Circular Cylinder	$L = 2\pi rh$
	Right Circular Cone	$L = \pi rl$ where l is the slant height

Surface Area	Sphere	$SA = 4\pi r^2$
--------------	--------	-----------------

Tear Here

Tear Here

Tear Here

Scrap Graph Paper — This sheet will *not* be scored.

Tear Here

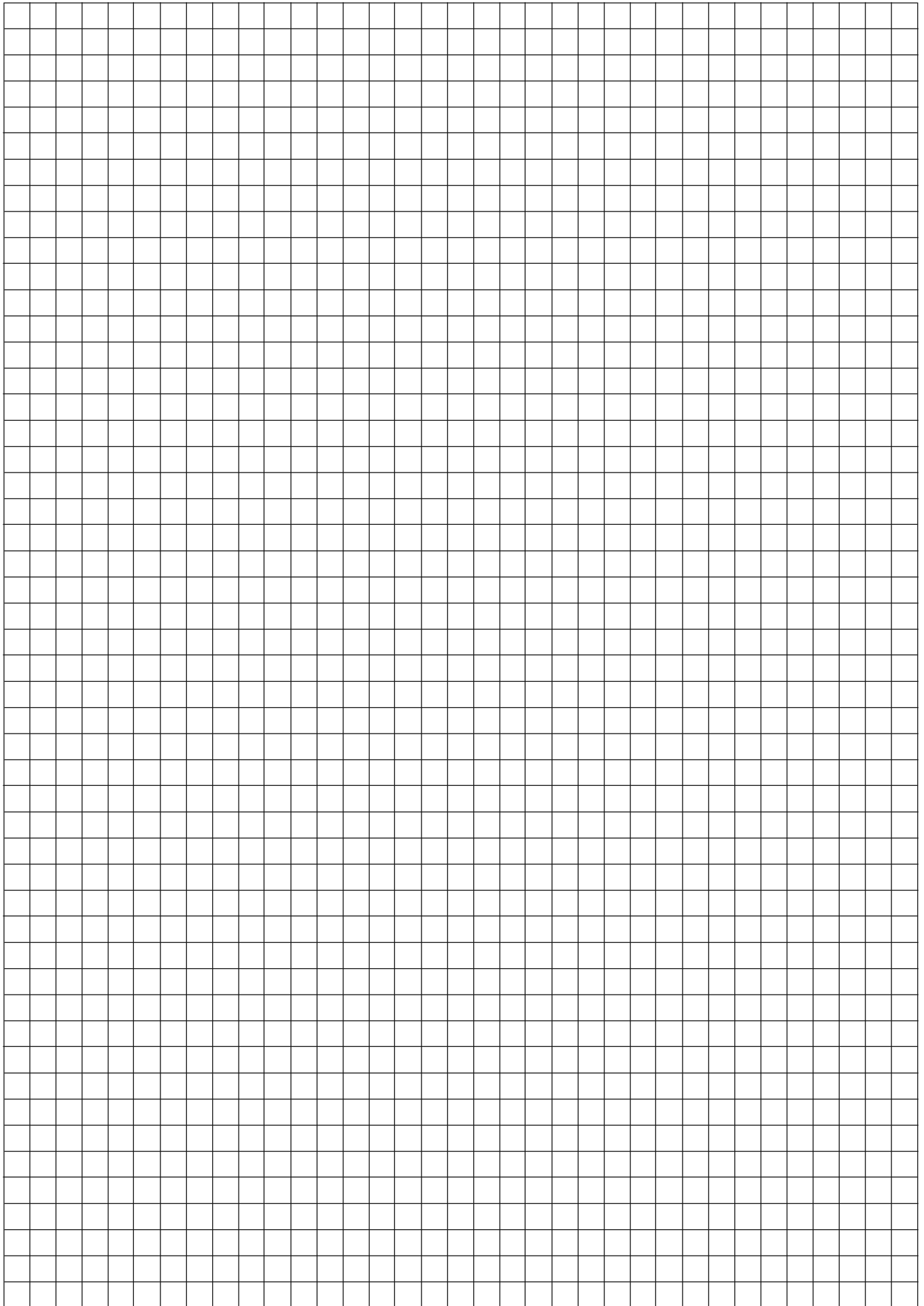

Tear Here

Scrap Graph Paper — This sheet will *not* be scored.

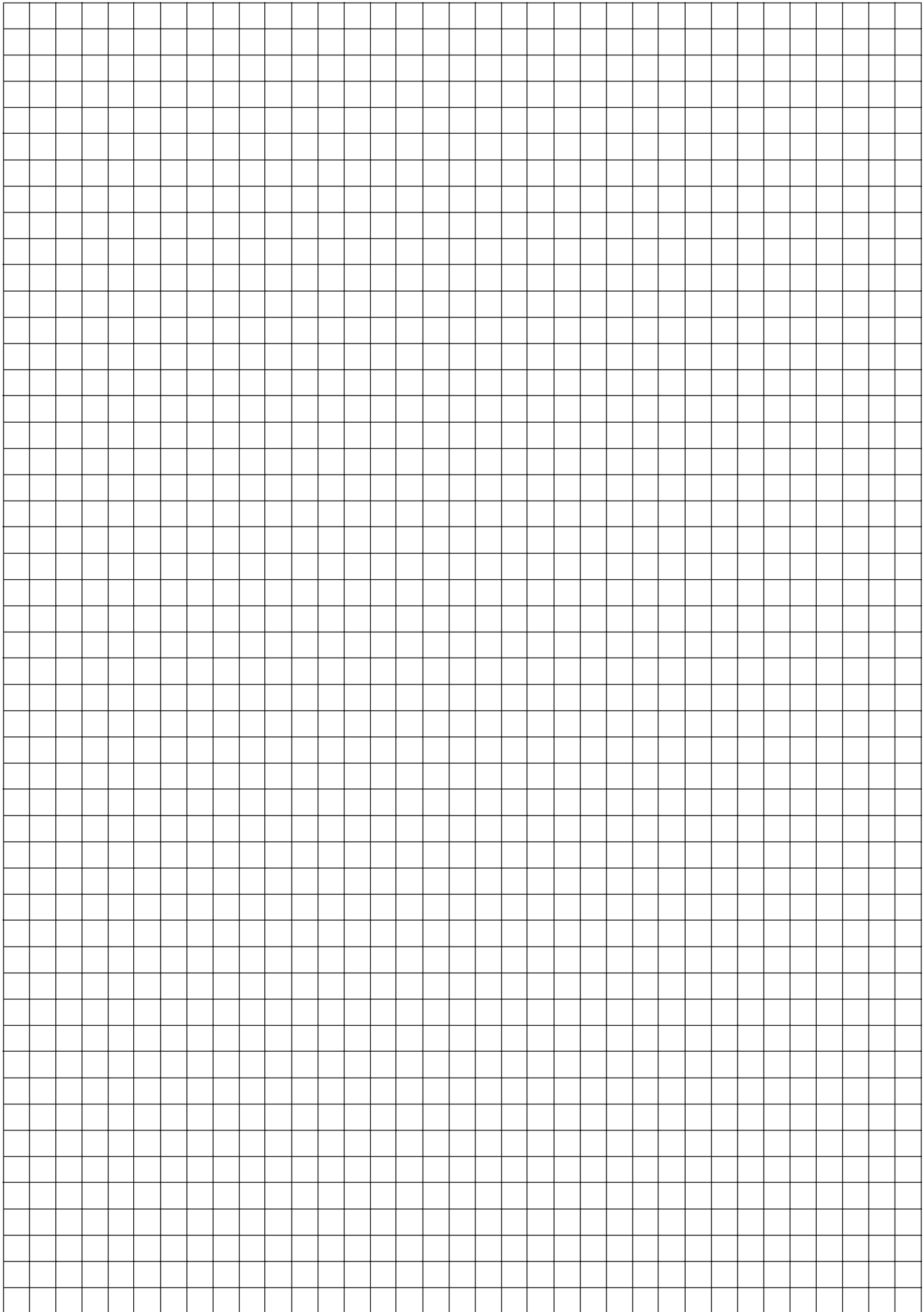

Tear Here

Tear Here

GEOMETRY