

LIVING ENVIRONMENT

Wednesday, June 13, 2018 — 1:15 to 4:15 p.m., only

Student Name _____

School Name _____

The possession or use of any communications device is strictly prohibited when taking this examination. If you have or use any communications device, no matter how briefly, your examination will be invalidated and no score will be calculated for you.

Print your name and the name of your school on the lines above.

A separate answer sheet for multiple-choice questions in Parts A, B-1, B-2, and D has been provided to you. Follow the instructions from the proctor for completing the student information on your answer sheet.

You are to answer all questions in all parts of this examination. Record your answers for all multiple-choice questions, including those in Parts B-2 and D, on the separate answer sheet. Record your answers for all open-ended questions directly in this examination booklet. All answers in this examination booklet should be written in pen, except for graphs and drawings, which should be done in pencil. You may use scrap paper to work out the answers to the questions, but be sure to record all your answers on the answer sheet or in this examination booklet as directed.

When you have completed the examination, you must sign the declaration printed on your separate answer sheet, indicating that you had no unlawful knowledge of the questions or answers prior to the examination and that you have neither given nor received assistance in answering any of the questions during the examination. Your answer sheet cannot be accepted if you fail to sign this declaration.

Notice ...

A four-function or scientific calculator must be available for you to use while taking this examination.

DO NOT OPEN THIS EXAMINATION BOOKLET UNTIL THE SIGNAL IS GIVEN.

Part A

Answer all questions in this part. [30]

Directions (1–30): For *each* statement or question, record on the separate answer sheet the *number* of the word or expression that, of those given, best completes the statement or answers the question.

1 Producers are generally found at the beginning of a food chain. Which statement best explains why this is true?

- (1) Producers are usually smaller in size than consumers.
- (2) Producers do not rely on other organisms for food.
- (3) There are always more consumers than producers in food chains.
- (4) Consumers are always more complex organisms than producers.

2 A lion cub resembles its parents because it inherits genes that produce

- (1) DNA identical to all of the DNA found in both parents
- (2) proteins identical to all of the proteins found in both parents
- (3) ATP identical to some of the ATP found in each parent
- (4) enzymes identical to some of the enzymes found in each parent

3 If body temperature is too high, some blood vessels increase in size and sweat glands will excrete sweat, resulting in a lower body temperature. These changes are an example of

- (1) a learned behavior
- (2) feedback mechanisms
- (3) an inherited disorder
- (4) genetic mutations

4 A farmer grows beans that he sells to local markets. Over a period of 40 years, the farmer has identified the plants that produced the most beans and only used those beans to produce new plants. This procedure is part of the process of

- (1) selective breeding
- (2) genetic engineering
- (3) replication
- (4) cloning

5 Although we rely on coal, oil, and natural gas to produce energy, some environmental scientists have proposed that we use less fossil fuel. One reason to support this proposal is to

- (1) enable us to preserve rain forests in tropical areas
- (2) help us to reduce the production of carbon dioxide gas
- (3) allow us to decrease the use of fertilizers on crops
- (4) encourage us to end research on wind and water power sources

6 The diagram below represents relationships in an ecosystem.

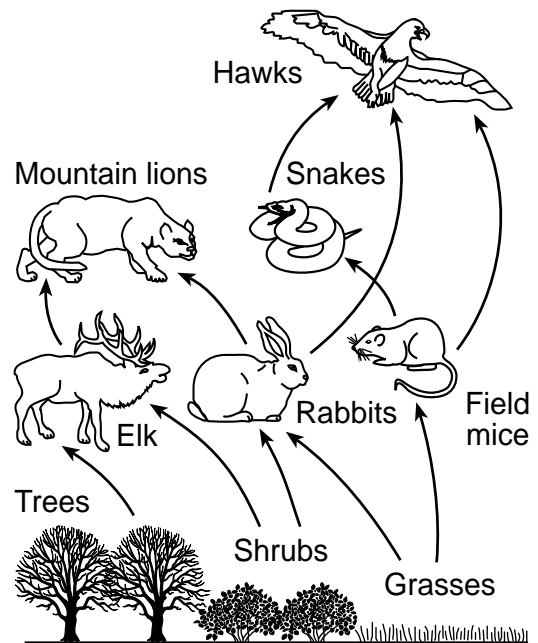

What is the primary source of energy in this environment?

- (1) cellular respiration in the plants
- (2) energy from minerals in the soil
- (3) fossil fuels
- (4) solar energy

7 Research has shown that treadmill training increases the number of certain energy-releasing structures in the brain cells of rats.

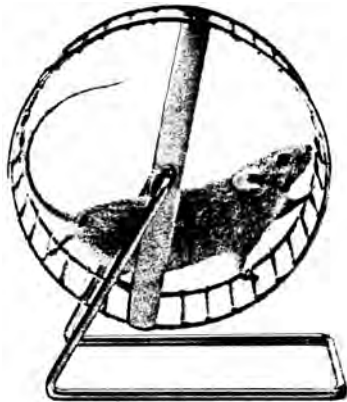

The cellular structures referred to in this study are most likely

- (1) mitochondria
- (2) nuclei
- (3) vacuoles
- (4) ribosomes

8 Which process must first take place in order for the proteins in foods to be used by body cells?

- (1) digestion
- (2) storage
- (3) synthesis
- (4) excretion

9 Which statement is characteristic of reproduction in humans?

- (1) The reproductive cells of males and females differ in chromosome number.
- (2) Males and females produce gametes in the ovaries.
- (3) Males and females produce the same number of gametes.
- (4) The reproductive cycles of males and females are regulated by hormones.

10 Which row in the chart below represents the most likely changes in the atmosphere due to widespread deforestation?

Row	Oxygen Concentration	Carbon Dioxide Concentration
(1)	increases ↑	increases ↑
(2)	increases ↑	decreases ↓
(3)	decreases ↓	increases ↑
(4)	decreases ↓	decreases ↓

11 The chart below represents some of the events that occur during the cycling of nutrients in an ecosystem.

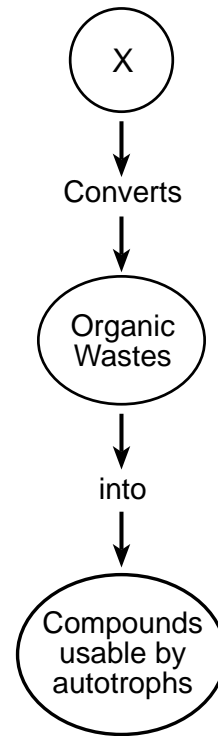

Which organisms would most appropriately complete the chart when written in the circle at X?

- (1) producers
- (2) herbivores
- (3) carnivores
- (4) decomposers

12 The diagram below represents the formation of a cancerous growth.

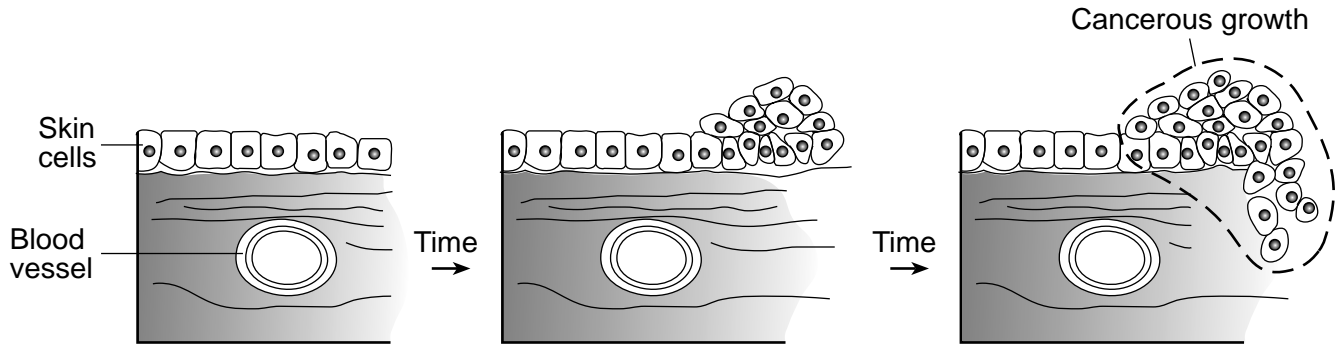

Which statement best explains the events represented in this diagram?

- (1) A gene mutation caused the cells to become muscle cells.
- (2) The growth resulted from the introduction of a vaccine.
- (3) A gene mutation caused abnormal mitotic cell division.
- (4) The growth resulted from uncontrolled meiotic cell division.

13 A standard laboratory technique used to produce a new plant is represented in the diagram below.

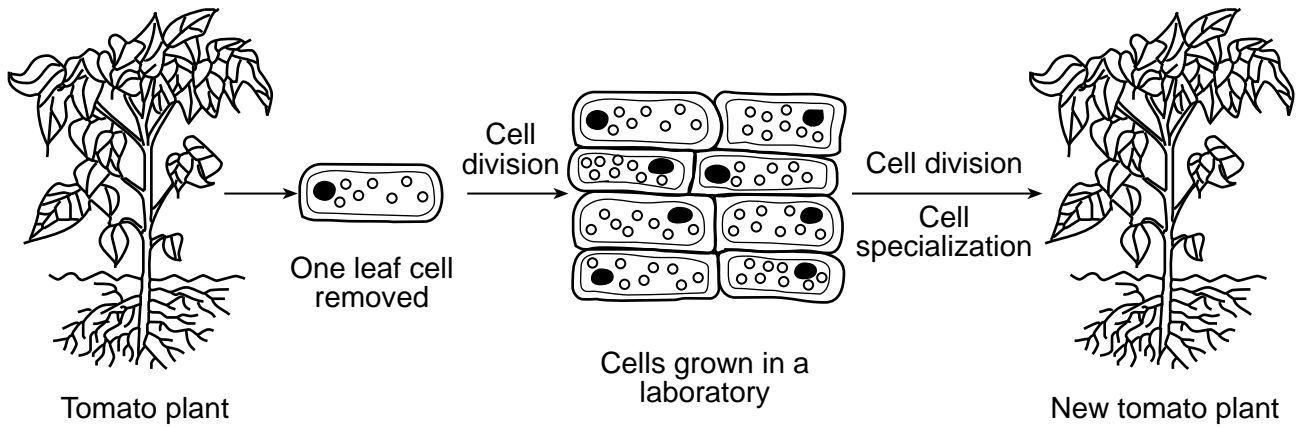

This technique is best identified as

- (1) gene alteration
- (2) selective breeding
- (3) replication
- (4) cloning

- 14 An example of competition between members of two different species is
- (1) mold growing on a dead tree that has fallen in the forest
 - (2) purple loosestrife plants growing in the same wet areas as cattail plants
 - (3) a coyote feeding on the remains of a deer that died of starvation
 - (4) two male turkeys displaying mating behaviors to attract a female turkey

- 15 Which statement best explains why different body cells of the same individual look and function differently?
- (1) Each cell contains different genes.
 - (2) Different genes are activated in different kinds of cells.
 - (3) Cells are able to change to adapt to their surroundings.
 - (4) Half of the genes in the cells came from the mother and half from the father.

- 16 A diagram of the female reproductive system is shown below.

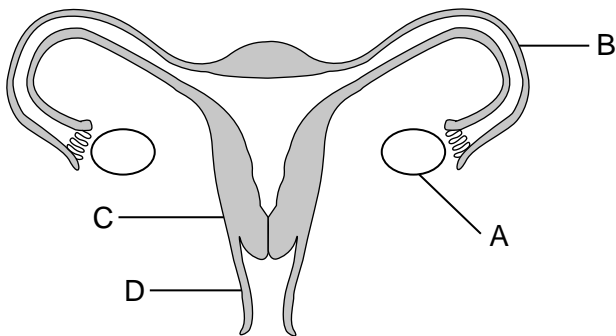

Identify the structure within which the egg cell is normally fertilized.

- (1) A
 - (2) B
 - (3) C
 - (4) D
- 17 The ameba, a single-celled organism, reproduces asexually. Variations in an ameba would most commonly occur through
- (1) differentiation during development
 - (2) the fusion of gametes
 - (3) random mutations
 - (4) recombination during fertilization

- 18 The development of organs and tissues from a zygote includes
- (1) mitosis and differentiation
 - (2) mitosis and gamete production
 - (3) meiosis and gamete production
 - (4) meiosis and fertilization

- 19 In the 1920s, over 25 million acres of the American southern plains were stripped of prairie grasses to provide more land for farmers to grow wheat. The prairie grasses had served to hold the soil in place and prevent erosion. In the early 1930s, a series of severe dust storms eroded topsoil from more than 13 million acres of the southern plains and dumped it as tons of dust particles over many cities in the Northeast. Farmland was destroyed and people were sickened from “dust pneumonia.” This occurrence illustrates that
- (1) farmers should never clear land to grow crops as it always creates problems
 - (2) once an ecosystem has been altered, it can not be restored to normal
 - (3) the farmers deliberately altered the equilibrium of the cities in the Northeast
 - (4) when humans alter ecosystems, serious consequences may result

- 20 The Cornell University News Service reported, “The sugar maple is the most economically valuable tree in the eastern United States because of its high-priced lumber, syrup and tourist-attracting fall colors.” The effects of acid rain now threaten the survival of these trees. This threat is the result of a human activity that has
- (1) introduced a foreign species by accident
 - (2) stabilized a forest ecosystem through technology
 - (3) weakened an ecosystem through pollution
 - (4) weakened a species by direct harvesting

- 21 The human male reproductive system is adapted for the production of
- (1) sperm and the delivery of these cells for internal fertilization
 - (2) gametes that transport food to the egg
 - (3) zygotes and the development of these cells into a fetus
 - (4) hormones that stimulate placenta formation in the male

22 The diagram below represents an important biological technique scientists rely on to produce replacement hormones.

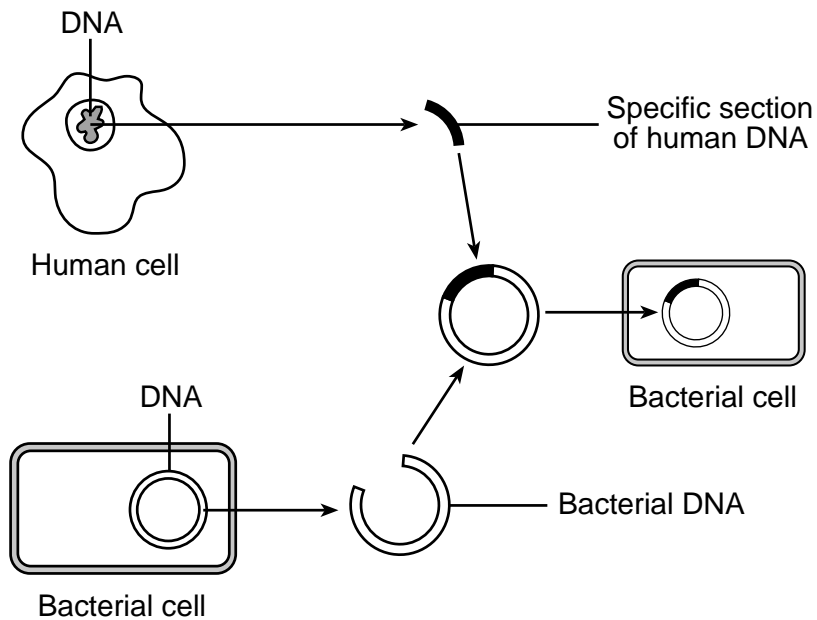

Which two processes are required for the technique to successfully produce hormones?

- (1) replication of DNA in bacterial cells and cell division
- (2) replication of DNA in bacterial cells and gamete formation
- (3) meiosis and development
- (4) mitosis and fertilization

23 The diagram below summarizes some of the steps in the development of humans.

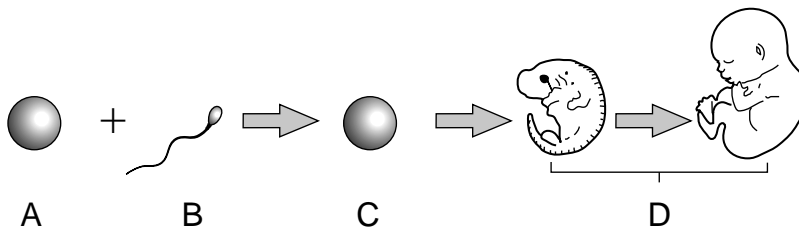

All the genetic information needed for the organism to develop is first present at

- (1) A
- (2) B
- (3) C
- (4) D

24 Five different living organisms are represented below.

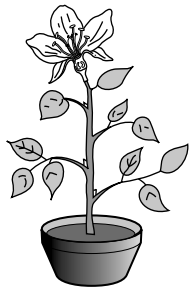

Flowering plant

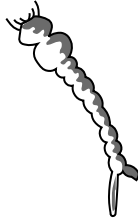

Mosquito larva



Frog



Green heron



Aquatic plant

(Not drawn to scale)

Which statement about the organisms represented above is correct?

- (1) All of the organisms are autotrophs.
- (2) Only the flowering plant, green heron, and aquatic plant carry out photosynthesis.
- (3) Only the frog and green heron can maintain homeostasis.
- (4) All of the organisms pass on traits through reproduction.

25 Mistletoe is an evergreen shrub that can produce most of its own food. Often, mistletoe can be found living on trees and taking water and nutrients away from the tissues of the trees.



The relationship between mistletoe and trees is an example of

- (1) consumer/herbivore
- (2) predator/prey
- (3) scavenger/decomposer
- (4) parasite/host

26 Rabbits are not native to Australia. They were imported by European settlers. In 1936, the myxoma virus was introduced into Australia as a means of biological control to infect and reduce the rabbit population. This method of controlling the rabbit population was an attempt to

- (1) stop the overpopulation of a native species
- (2) stop the overproduction of an introduced species
- (3) limit the food sources of the rabbit
- (4) limit the number of rabbits brought into the country

27 The major role of carbohydrates in the human diet is to

- (1) form the membranes that surround mitochondria
- (2) act as a catalyst for cellular reactions
- (3) supply energy for the body
- (4) provide building blocks for amino acids

28 Throughout New York State, some farmers have switched from growing a variety of vegetable crops to growing a single crop, such as corn. Other farmers are concerned that such a practice will make it more likely that an entire crop could be lost to disease or infestation by an insect pest. This is a valid concern because this practice

- (1) reduces the biodiversity of their fields
- (2) increases the number of decomposers in their fields
- (3) decreases the need to import food
- (4) increases the number of invasive species

29 The breathing rate, heart rate, and blood hormone levels of an individual would directly provide information about that individual's

- (1) cellular organization
- (2) nutrition
- (3) inheritance
- (4) metabolic activity

30 The diagram below represents an energy pyramid.

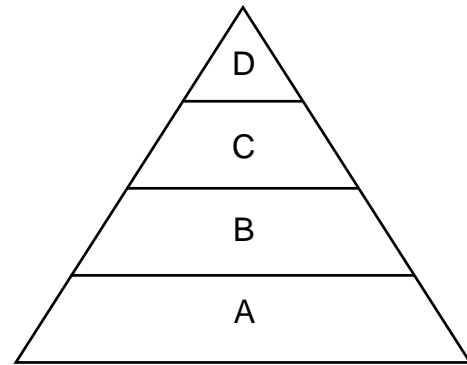

Which type of organism could occupy levels B, C, and D of this energy pyramid?

- (1) consumer
 - (2) producer
 - (3) autotroph
 - (4) carnivore
-

Part B-1

Answer all questions in this part. [13]

Directions (31–43): For *each* statement or question, record on the separate answer sheet the *number* of the word or expression that, of those given, best completes the statement or answers the question.

31 In the 1920s, two conflicting newspaper headlines called attention to a mysterious new illness.

1921–“Don’t breathe the air! Mysterious disease affecting thousands is caused by breathing the air in swamps.”

1922–“Don’t drink the water! Mysterious disease affecting thousands is caused by drinking the water in swamps.”

Another series of headlines appeared in the 1940s and 50s.

1945–“New technology finds tiny worms on swamp vegetation.”

1950–“Tiny worms found in lungs of patients suffering from mysterious swamp disease.”

1952–“Mysterious disease known to be caused by worms given name Swamp Lung Disease.”

Headlines such as these best illustrate the concept that

- (1) scientific explanations are tentative and subject to change
- (2) some newspapers are not honest and report incorrect information on purpose
- (3) worms can enter the body many different ways
- (4) worms found in swamps should not be used for fishing

Base your answer to question 32 on the information and diagram below and on your knowledge of biology.

In the early 1600s, a scientist planted a willow tree that weighed 5 pounds in 200 pounds of dry soil. He placed it outside and watered it for 5 years. At the end of that time, he observed that the tree had gained 164 pounds 3 ounces, while the soil had lost just 2 ounces.

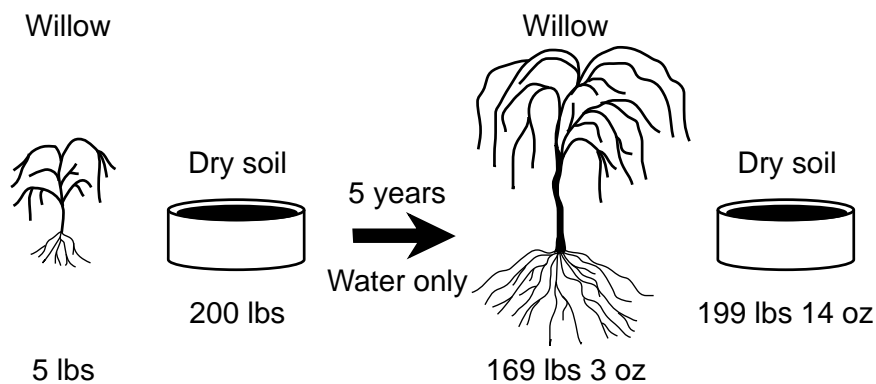

32 From this, he concluded that plants gain weight from the water they take in. His conclusion was based on

- (1) the input of scientists from many countries doing similar studies
- (2) the application of advanced technologies to the study of a problem
- (3) careful observation, measurements, and inferences from his data
- (4) an extensive knowledge of the process of photosynthesis

- 33 A student observed five living cells in the field of view of a microscope as represented below.

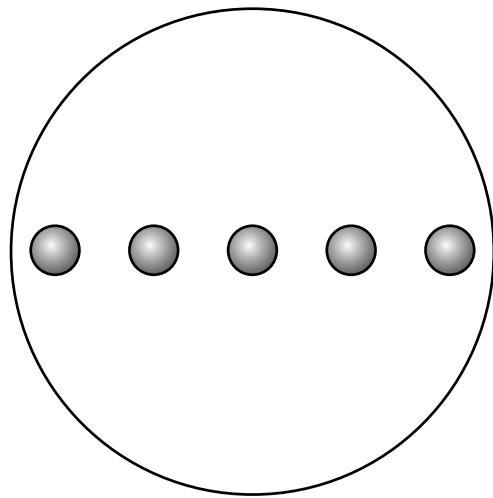

Diameter = 500 μm

What is the approximate diameter of one cell?

- (1) 10 μm (3) 250 μm
(2) 50 μm (4) 500 μm
- 34 Ecologists are concerned that the golden-winged warbler population is at a dangerously low level. One reason this could lead to extinction of this warbler is that
- (1) after a species becomes extinct, it won't be able to carry out its role in the ecosystem
 - (2) there may not be enough diversity among the birds for the species to be able to survive an environmental change
 - (3) extinction always occurs when populations begin to decrease in number
 - (4) an increase in biodiversity within a population often causes the population to be classified as threatened or endangered
- 35 One primary function of the cell membrane is
- (1) regulating the flow of simple sugars into or out of the cell
 - (2) synthesizing substances by breaking down cell organelles
 - (3) storing carbohydrates, water, and starches for future use
 - (4) digesting carbohydrates, fats, and protein

- 36 For several years now, there has been discussion of constructing a large oil pipeline across the United States. Which statement expresses a major concern many people are likely to have about the proposed pipeline?

- (1) The pipeline will bring a large number of jobs to the area where it is being constructed.
- (2) The oil pipeline will increase the amount of finite resources.
- (3) If this pipeline were to leak, the oil could contaminate soil, water, and wildlife.
- (4) The pipeline is a technological fix for ozone depletion.

- 37 The rings in the diagram below represent the annual growth of a tree approximately 20 years old.

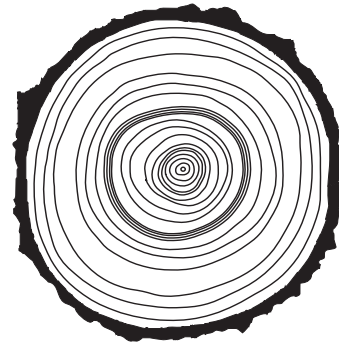

Tree trunks grow wider each year by continuous growth in a thin layer of cells just beneath the bark. Since one new layer is added each year, the number of rings in a tree can be used to tell its age. The thickness of the rings provides information about the environmental conditions in past years.

By observing the annual rings in the diagram, one can infer that

- (1) environmental conditions did not change over the last 20 years
 - (2) trees grow faster on the side that faces the Sun
 - (3) some years provide better conditions for growth than other years
 - (4) tree rings are not reliable because trees must be cut down to see them
-

Base your answers to questions 38 through 40 on the information below and on your knowledge of biology.

Harmless Skin Virus Fights Acne

...Acne is caused when hair follicles become blocked with an oily substance called sebum, which the body makes to stop the hair and skin from drying out.

Normally harmless bacteria, such as *Propionibacterium acnes*, that live on the skin can then contaminate and infect the plugged follicles.

Phages [a type of virus] appear to help counteract this.

When the scientists sequenced the DNA coding of the phages, they discovered that, as well as sharing most of their genetic material, the viruses all had some key features in common.

All carry a gene that makes a protein called endolysin – an enzyme thought to destroy bacteria by breaking down their cell walls.

And unlike antibiotics, which kill many types of bacteria, including “good” ones that live in our gut, phages are programmed to target only specific bacteria...

Source: BBC News
September 25, 2012

38 This treatment for acne, using phages, is effective because phages

- (1) produce antibodies to clean out clogged pores and hair follicles
- (2) eliminate bacteria by attacking specific cell structures
- (3) carry genes and infect follicles
- (4) attack every known type of bacteria

39 The protein endolysin belongs to which group of chemical substances?

- (1) hormones
- (2) receptors
- (3) biological catalysts
- (4) molecular bases

40 The typical response of the human body to an infection by bacteria is to

- (1) stimulate the production of antigens
 - (2) decrease the number of enzymes in the blood
 - (3) ignore the organisms, unless they are pathogens
 - (4) produce white blood cells and antibodies
-

41 Two biological processes that occur in certain organelles are represented in the diagrams below.

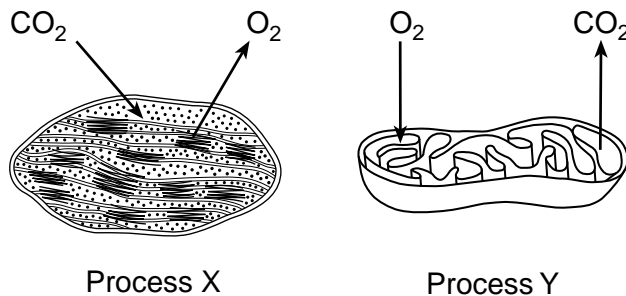

Which statement is correct regarding the types of organisms able to carry out these processes?

- (1) Process X occurs in heterotrophs, but not in autotrophs.
- (2) Process Y occurs in consumers, but not in producers.
- (3) Both processes X and Y occur in all living things.
- (4) Both processes X and Y occur in green plants.

Base your answers to questions 42 and 43 on the diagram below and on your knowledge of biology. The diagram shows how ATP is used by some cell structures to perform various functions.

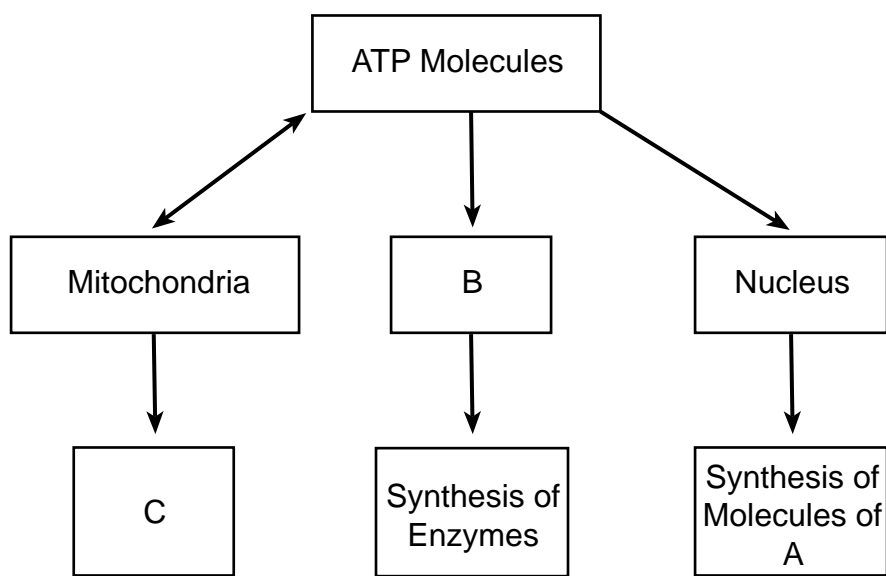

42 Which cell structure is represented by B?

- (1) vacuole
- (2) ribosome
- (3) cytoplasm
- (4) chloroplast

43 The nucleus contains molecules of A, which

- (1) recycle waste products
- (2) remove water from the cell
- (3) store hereditary information
- (4) regulate the pH of cytoplasm

GO ON TO THE NEXT PAGE ⇨

Part B–2

Answer all questions in this part. [12]

Directions (44–55): For those questions that are multiple choice, record on the separate answer sheet the *number* of the choice that, of those given, best completes each statement or answers each question. For all other questions in this part, follow the directions given and record your answers in the spaces provided in this examination booklet.

Base your answers to questions 44 through 47 on the information and data table below and on your knowledge of biology.

Moose-killing Winter Ticks

Moose habitat is determined by temperature. Moose prefer areas where the average summer temperature is around 15°C and does not exceed 27°C for too long. The reason for this temperature dependency: Moose cannot sweat.

Besides the cooling effect of water, which moose are almost always near, aquatic environments provide them with a good supply of food, and in the past, have protected them against biting insects. However, the North American moose population is facing a new threat: a parasite called the winter tick. These ticks lodge themselves in the animal's fur and hold on through the winter, sucking the animal's blood. Many infected moose end up dying of exhaustion and weakness as a result of the large number of ticks feeding on them.

Ticks are most active during dry days in the fall. Adult ticks that drop off moose in the spring and land on snow cover have a poorer survival rate. Climate change can be predicted to improve conditions for winter ticks due to longer and warmer falls, and earlier snowmelt in the spring.

Surveys of the moose population in northeastern Minnesota have recorded the change shown below in the moose population between 2005 and 2013.

**Estimated Moose Population
In Northeastern Minnesota**

Survey Year	Estimated Moose Population
2005	8160
2006	8840
2007	6860
2008	7890
2009	7840
2010	5700
2011	4900
2012	4230
2013	2760

Directions (44–45): Using the information in the data table, construct a line graph on the grid below, following the directions below.

44 Mark an appropriate scale, without any breaks in the data, on the axis labeled “Estimated Moose Population.” [1]

45 Plot the data for the estimated moose population on the grid. Connect the points and surround each point with a small circle. [1]

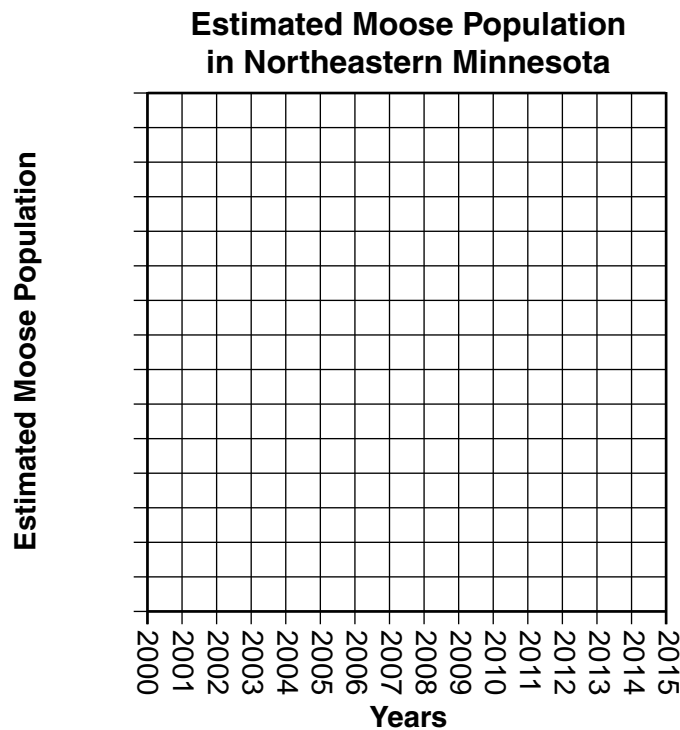
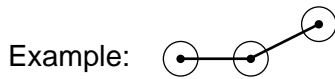

46 Explain how climate change could result in an increased number of moose infested with winter ticks. [1]

Note: The answer to question 47 should be recorded on your separate answer sheet.

47 Increased average yearly temperatures in regions presently inhabited by moose could result in a disruption in homeostasis in these animals because

- (1) a decrease in average temperatures will increase mutations in their skin cells
- (2) an increase in average temperatures will decrease the amount of blood ticks can consume
- (3) moose will not be able to maintain an appropriate body temperature, since they do not sweat
- (4) moose will sweat more and lose too much water from their bodies

Base your answers to questions 48 and 49 on the information and diagram below and on your knowledge of biology. The diagram represents the evolutionary relationships among many organisms.

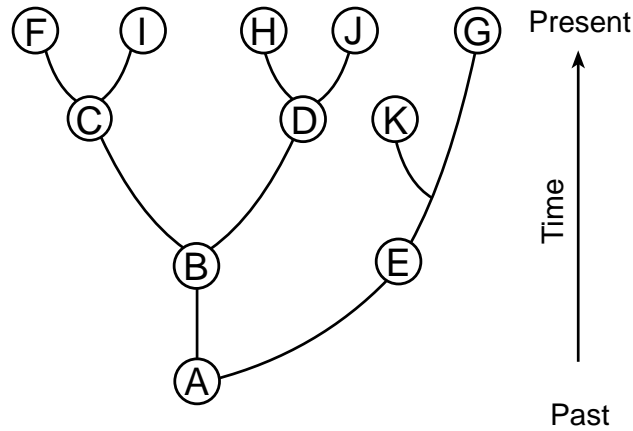

48 An environmental change severely affected the organism represented by species *K*. What was the result? Support your answer. [1]

Note: The answer to question 49 should be recorded on your separate answer sheet.

49 Three species with the most similar traits are most likely

- | | |
|--------------------|--------------------|
| (1) <i>F, I, G</i> | (3) <i>B, D, G</i> |
| (2) <i>D, H, J</i> | (4) <i>F, A, J</i> |

Base your answers to questions 50 and 51 on the diagram below and on your knowledge of biology. The diagram represents trophic levels in an ocean environment.

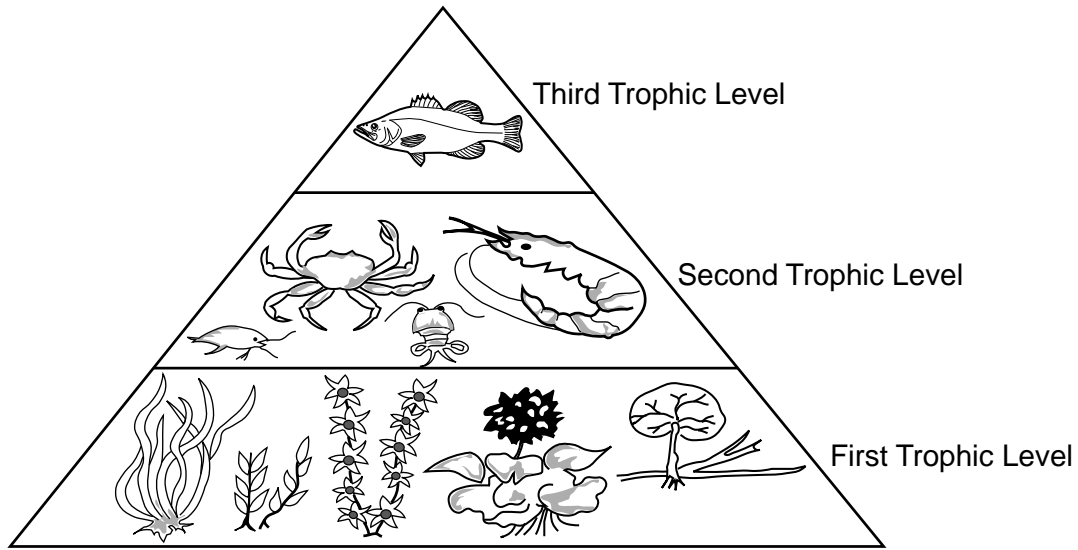

Note: The answer to question 50 should be recorded on your separate answer sheet.

50 The organisms found at the second trophic level of this pyramid would be

- (1) producers
- (2) decomposers
- (3) carnivores
- (4) herbivores

51 State *one* reason why there is less energy available at each trophic level going from the first to the third trophic level. [1]

52 Stable predator-prey relationships are necessary to maintain a healthy ecosystem. The removal of a predator species from an area caused the deer population to sharply increase from 1910 to 1925. Changes in the deer population and carrying capacity of the area are represented in the graph below.

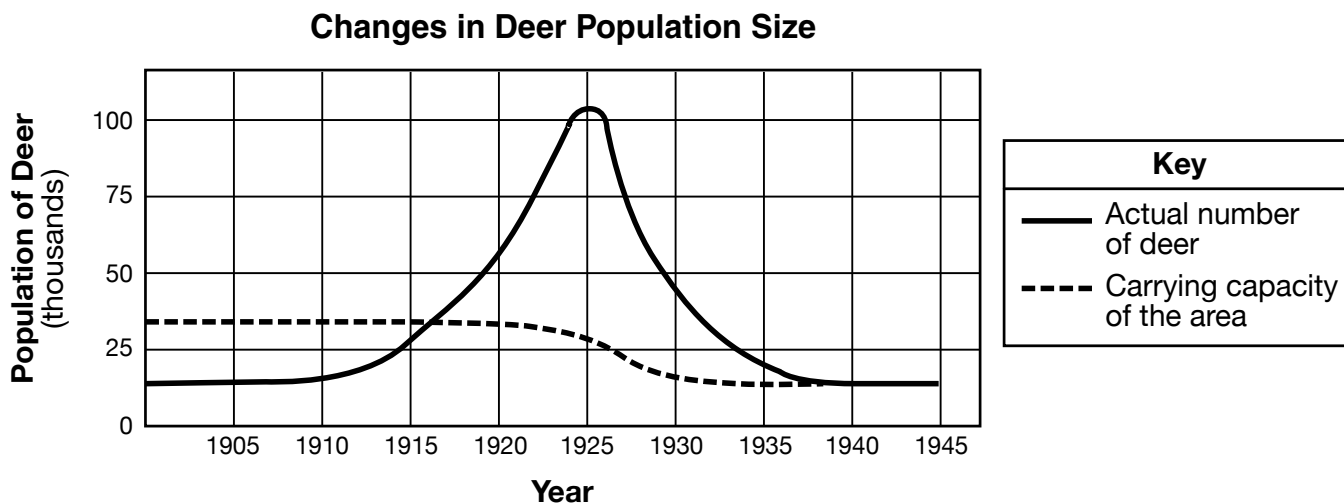

Based on the information provided, explain how the sharp population increase from 1910 to 1925 might have resulted in the decrease in the carrying capacity after 1925. [1]

Base your answers to question 53–54 on the diagram below and on your knowledge of biology. The diagram indicates a change in an ecosystem.

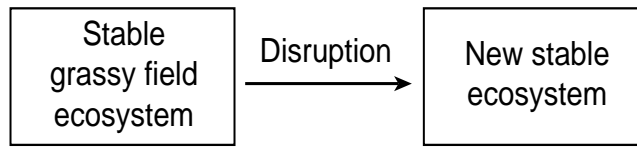

53–54 Identify some of the key events associated with the change. In your answer, be sure to:

- identify *one* natural event that could cause the disruption indicated in the diagram [1]
- state what would most likely happen to the new stable ecosystem in future years if no further disruptions occur [1]

55 Explain why a mutation that occurs in a body cell will *not* contribute to the evolution of a species. [1]

Part C

Answer all questions in this part. [17]

Directions (56–72): Record your answers in the spaces provided in this examination booklet.

Base your answers to questions 56 through 58 on the passage below and on your knowledge of biology.

Our [Nitrogen] Fertilized World

It is the engine of agriculture, the key to plenty in our crowded, hungry world. ...

...Enter modern chemistry. Giant factories capture inert nitrogen gas from the vast stores in our atmosphere and force it into a chemical union with the hydrogen in natural gas, creating the reactive compounds that plants crave. That nitrogen fertilizer – more than a hundred million tons applied worldwide every year – fuels bountiful harvests. Without it, human civilization in its current form could not exist. Our planet’s soil simply could not grow enough food to provide all seven billion of us our accustomed diet. In fact, almost half of the nitrogen found in our bodies’ muscle and organ tissue started out in a fertilizer factory.

Source: National Geographic, May 2013

56 Nitrogen fertilizers are used by plants to synthesize amino acids. State *one* reason why a supply of amino acids is important for the survival of complex organisms. [1]

57 Identify *one* possible effect on the human population if nitrogen fertilizers were not available. [1]

58 Explain how the building of factories to produce fertilizer is an example of a trade-off. [1]

Base your answers to question 59–60 on the information and diagram below and on your knowledge of biology.

An experiment was carried out to determine the effect of exposure to ultraviolet (UV) light on the growth of bacteria. Equal quantities of bacterial cells were spread on Petri dishes that are used to grow colonies of bacteria. Half of each dish was shielded from the UV light with a UV screen. The other half was exposed to UV light for various amounts of time. After the UV treatment, the bacteria were grown in an incubator for 24 hours and the number of colonies was counted.

The diagram below represents the setup of the experiment.

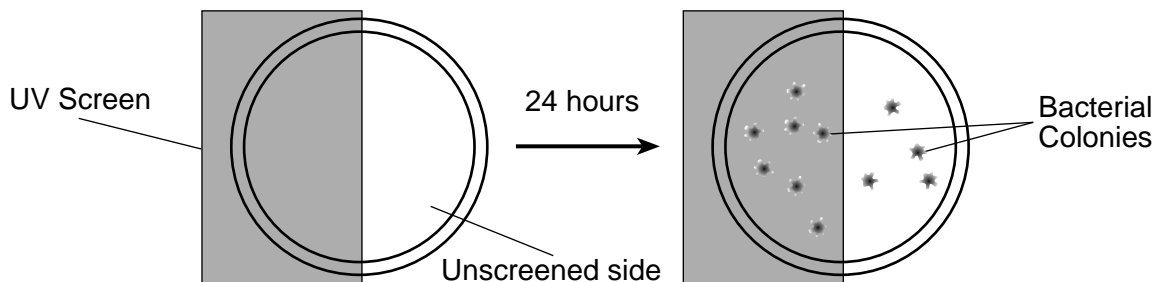

The table below contains the data collected at different exposure times by counting the number of bacterial colonies on both the screen-covered side and unscreened side.

Bacterial Growth

Exposure Time to UV Light (min)	Colonies on Screened Side	Colonies on Unscreened Side
0 (No exposure)	20	22
0.5	21	19
1.0	23	16
2.0	22	10
5.0	24	5
10.0	23	1

59–60 Analyze the experiment that produced the data in the table. In your answer, be sure to:

- state a hypothesis for the experiment [1]
- state whether the results of the experiment support or fail to support your hypothesis. Support your answer [1]

Base your answers to questions 61 and 62 on the information below and on your knowledge of biology.

Evolution leads to changes in how frequently certain traits appear in a population.

61 Explain the importance of the presence of variations within a population. [1]

62 Describe how the process of natural selection can result in an increase in frequencies of certain traits found in a population. [1]

Base your answers to questions 63 through 65 on the information below and on your knowledge of biology.

A typical human liver cell can have over 90,000 insulin receptors. Due to a genetic difference, some people have liver cells that contain only about 1000 insulin receptors.

63 Describe the importance of receptors in cellular communication. [1]

64 Describe the importance of the shape of receptor molecules for carrying out their function. [1]

65 Identify *one* effect a reduced number of insulin receptors might have on an individual. [1]

Base your answers to questions 66 through 68 on the passage below and on your knowledge of biology. Biologists have been studying the genes present in newborn twins.

Twins Don't Share Everything

...Chemicals called epigenetic markers can be attached to those [inherited] genes, like flags or balloons hanging off the sides of the DNA ladder. These don't just change the look of the genes. Like pieces of tape stuck over a light switch, these markers can force a gene to remain turned on or off. The type of marker scientists studied in the twins generally sticks the switch in the off position so that some proteins don't get made. And that means the proteins' jobs won't get done.

Every time a cell divides, new epigenetic markers may form. Foods, pollutants, and stress may all contribute to the development of new markers. So throughout our lives we tend to accumulate more and more. But a few are there from the day we're born.

...His [Jeffrey Craig's] team found that newborn twins have markers attached to different genes from the very start. It's true in identical twins, which come from the same fertilized egg. It's also true in fraternal twins, which come from different fertilized eggs. However, fraternal twins had more such differences than identical twins did.

Source: Science News for Students; July 31, 2012

- 66 Explain why the genetic material in an offspring produced by sexual reproduction contains genetic material that is *not* identical to the genetic material of either parent. [1]

- 67 State *one* reason why identical twins should have fewer genetic differences than fraternal twins. [1]

- 68 Identify *two* environmental factors that can lead to an increase in the number of epigenetic markers that modify gene expression. [1]

Base your answers to questions 69 and 70 on the information below and on your knowledge of biology.

With the emotional roller coaster that pregnancy brings, it can be daunting [challenging] for pregnant women to take on the additional pressure of eating the “perfect” pregnancy diet. The good news: there is no single perfect diet for pregnancy. The best way for expectant mothers to meet their nutritional needs is to focus on consuming an overall healthy diet, with a variety of vegetables, fruits, whole grains, lean meats or meat substitutes, and low-fat dairy or dairy substitutes....

Source: US News Health 11/9/2012

69 Describe how nutrients move from the mother to the fetus. [1]

70 State *one* other way, in addition to consuming a balanced diet, pregnant women can help ensure proper development of the fetus. [1]

Base your answer to question 71 on the information below and on your knowledge of biology.

...Bacteria often evolve clever ways of evading chemical assaults, but they will always struggle to resist the old-fashioned way of killing them; heating them up. It takes only a relatively mild warming to kill bugs [bacteria] without discomfort or harm to tissues. So imagine if little electric heaters could be implanted into wounds and powered wirelessly to fry bacteria during healing before dissolving harmlessly into body fluids once their job is done....

Source: BBC Future, May 24, 2013

71 State *one* way the use of these new “little electric heaters” might represent a long-term benefit over using antibiotics to treat bacterial infections. [1]

72 A child became ill with the measles. Measles is a disease that is highly contagious. The child’s mother did not get sick, even though she and the child were close while the child was ill. State *one* reason why the mother did not get sick with the measles. [1]

Part D

Answer all questions in this part. [13]

Directions (73–85): For those questions that are multiple choice, record on the separate answer sheet the *number* of the choice that, of those given, best completes each statement or answers each question. For all other questions in this part, follow the directions given and record your answers in the spaces provided in this examination booklet.

Note: The answer to question 73 should be recorded on your separate answer sheet.

73 The diagram below represents the major parts of a growing onion plant. Nutrients are represented in the soil around the onion.

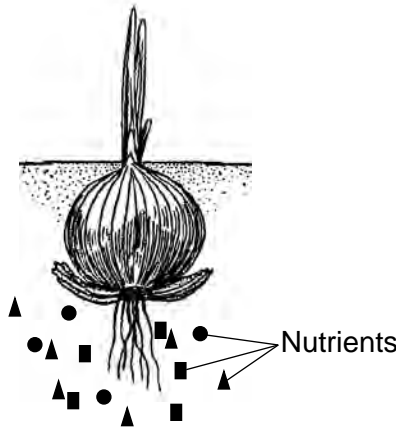

Which statement best describes how nutrients enter the root cells of the onion plant?

- (1) Only nutrients needed by the plant enter root cells.
- (2) The nutrients usually move from an area of high concentration in the soil to an area of low concentration in root cells.
- (3) Nutrients always move into the plant cells by active transport.
- (4) The nutrients always move from an area of low concentration in the soil to an area of high concentration in root cells.

Note: The answer to question 74 should be recorded on your separate answer sheet.

74 Which concept is correctly matched with an example from *The Beaks of Finches* lab?

- (1) Variation – different “beaks” were available.
- (2) Adaptation – different types of foods were available.
- (3) Selecting Agent – an insecticide was used to kill insects on one island.
- (4) Environment – “beaks” with similar qualities were used to gather seeds.

Note: The answer to question 75 should be recorded on your separate answer sheet.

- 75 When comparing characteristics of two organisms, which evidence would be considered the strongest for supporting a possible evolutionary relationship?
- (1) The two organisms are the same color.
 - (2) The two organisms are the same height.
 - (3) The two organisms produce many of the same proteins.
 - (4) The two organisms are found in the same locations.

Note: The answer to question 76 should be recorded on your separate answer sheet.

- 76 *A* and *B* below represent two different slide preparations of elodea leaves. Elodea is a plant found in streams and ponds in New York State.

The water used on slide *A* contained 1% salt and 99% water.

The salt solution used on slide *B* contained 6% salt and 94% water.

Elodea cells normally contain 1% salt.

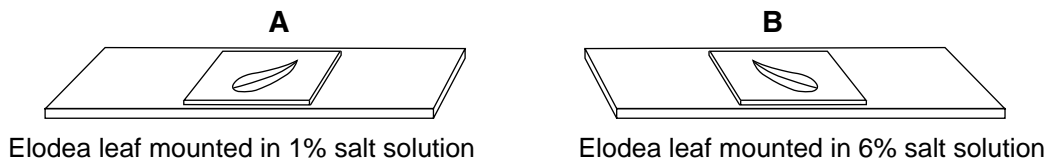



Five minutes after the slides were prepared, a student using a compound light microscope to observe the cells in leaves *A* and *B* would most likely see that

- (1) water had moved out of the cells of the leaf on slide *A*
- (2) salt had moved into the cells of the leaf on slide *A*
- (3) water had moved out of the cells of the leaf on slide *B*
- (4) salt had moved out of the cells of the leaf on slide *B*

77 The table below shows the food sources for two different species of Galapagos finches on an island.

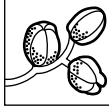
Two Galapagos Finches and Their Sources of Food

Name	Foods
Vegetarian finch <i>Platyspiza crassirostris</i> 	Buds, leaves, fruit of trees 
Cactus finch <i>Geospiza scandens</i> 	Cactus flowers and nectar 

State *one* reason why these two species probably do *not* live in the same area of this island. [1]

Base your answers to questions 78 and 79 on the information below and on your knowledge of biology.

During a lab activity, a 14-year-old student took his resting pulse rate. He counted 20 beats in 20 seconds. He calculated his pulse rate for a minute and compared the result to the data shown in the table below.

Normal Pulse Rate Ranges

Age Group	Resting Heart Rate (beats per minute)
Children (ages 6-15)	70 – 100
Adults (ages 18 and over)	60 – 100

78 According to the data table, does the student’s pulse rate fall within the normal range? Circle yes or no and support your answer. [1]

yes no

79 Using a biological explanation, state *one* reason why a person’s heart rate increases during exercise. [1]

80 The chart below shows the molecular comparison between several species.

Molecular Comparison Chart

<i>Botana curus</i>	DNA	GTG	GAC	TGA	GGA	CTC
	mRNA	CAC	CUG	ACU	CCU	GAG
	Amino acid	His	Leu	Thr	Pro	Glu

Species X	DNA	GTG	GAC	AGA	GGA	CAC
	mRNA	CAC	CUG	UCU	CCU	GUG
	Amino acid	His	Leu	Ser	Pro	Val

Species Y	DNA	GTG	GAC	AGA	GGA	CAC
	mRNA	CAC	CUG	UCU	CCU	GUG
	Amino acid	His	Leu	Ser	Pro	Val

Species Z	DNA	GTA	GAC	TGA	GGA	CTC
	mRNA	CAU	CUG	ACU	CCU	GAG
	Amino acid	His	Leu	Thr	Pro	Glu

Identify which species is likely to be more closely related to *Botana curus*. Support your answer. [1]

Species: _____

Support: _____

Note: The answer to question 81 should be recorded on your separate answer sheet.

81 A factor that contributed to the evolution of finches on the Galapagos Islands was most likely the

- (1) lack of variation in beak structure of the finches
- (2) isolation of the finches on separate islands
- (3) relatively constant atmospheric temperature
- (4) total lack of competition for food

Base your answers to questions 82 and 83 on the diagram below and on your knowledge of biology. The diagram represents a laboratory setup.

A starch solution in a test tube was separated from the water in a beaker by a dialysis membrane. One hour later, it was observed that the liquid had risen in the test tube.

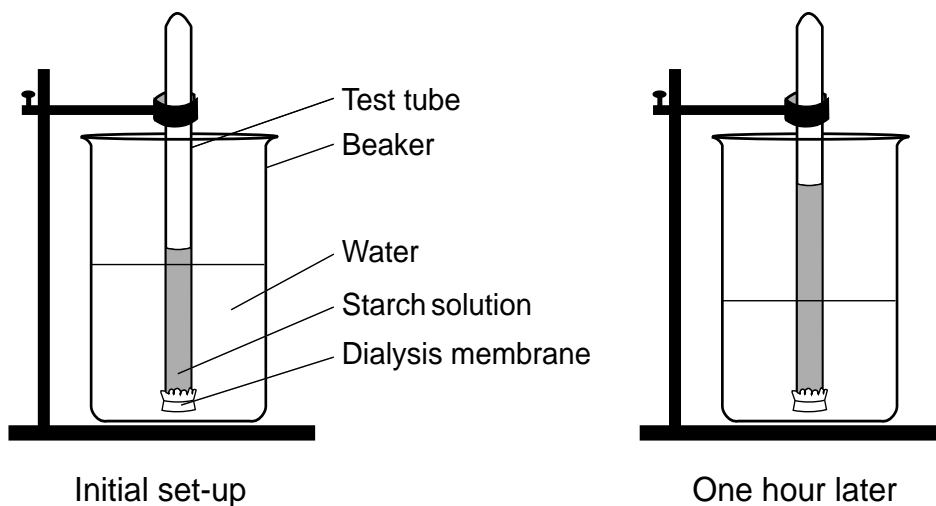

Note: The answer to question 82 should be recorded on your separate answer sheet.

82 The rise of the liquid in the test tube that was observed after one hour can be explained as a result of the

- (1) starch solution moving into the test tube and out of the beaker
- (2) water moving from the beaker into the test tube
- (3) large starch molecules blocking the dialysis membrane
- (4) dialysis membrane acting as a barrier to the water molecules

83 If a starch indicator solution was initially added to the water in the beaker, describe *one* observation that would be made after one hour. [1]

84 The diagram below represents an electrophoresis gel that was used to separate DNA fragments. Lanes 1, 2, and 3 contain DNA samples that were treated with the same restriction enzyme.

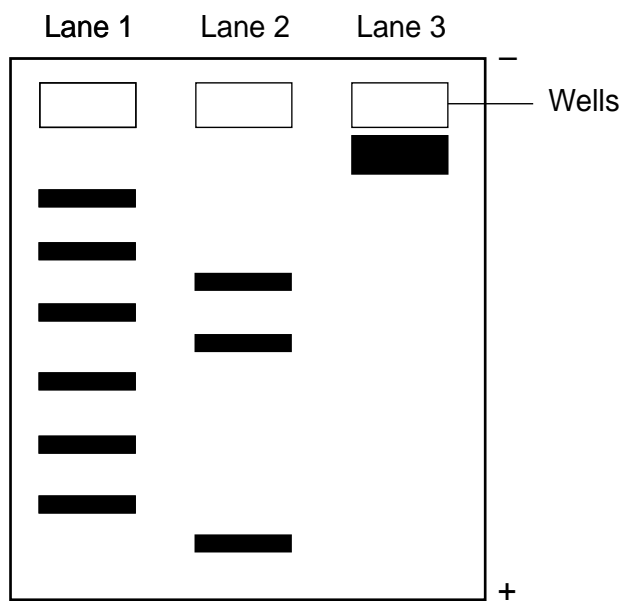

Explain why the DNA sample in lane 3 did *not* separate into fragments. [1]

85 An experiment is performed to determine the effect of watching basketball games on pulse rates. Ten students agreed to wear devices that monitor pulse rates while watching a basketball game between competitive opponents. Their pulse rates were measured every minute for five minutes in the first quarter of the game. The data collected indicated that pulse rates did not change significantly during the monitored period. State *one* way that this experiment could be improved to obtain a valid conclusion. [1]

LIVING ENVIRONMENT

Printed on Recycled Paper

LIVING ENVIRONMENT