

The University of the State of New York
REGENTS HIGH SCHOOL EXAMINATION

LIVING ENVIRONMENT

Tuesday, August 13, 2002 — 12:30 to 3:30 p.m., only

Student Name _____

School Name _____

Print your name and the name of your school on the lines above. Then turn to the last page of this booklet, which is the answer sheet for Part A. Fold the last page along the perforations and, slowly and carefully, tear off the answer sheet. Then fill in the heading of your answer sheet.

This examination has three parts. You must answer all questions in this examination. Write your answers to the Part A multiple-choice questions on the separate answer sheet. Write your answers for the questions in Parts B and C directly in this examination booklet. All answers should be written in pen, except for graphs and drawings which should be done in pencil. You may use scrap paper to work out the answers to the questions, but be sure to record all your answers on the answer sheet and in this examination booklet.

When you have completed the examination, you must sign the statement printed on the Part A answer sheet, indicating that you had no unlawful knowledge of the questions or answers prior to the examination and that you have neither given nor received assistance in answering any of the questions during the examination. Your answer sheet cannot be accepted if you fail to sign this declaration.

DO NOT OPEN THIS EXAMINATION BOOKLET UNTIL THE SIGNAL IS GIVEN.

Part A

Answer all questions in this part.

Directions (1–35): For *each* statement or question, select the choice that best completes the statement or answers the question. Record your answer on the separate answer paper.

1 A student formulated a hypothesis that cotton will grow larger bolls (pods) if magnesium is added to the soil. The student has two experimental fields of cotton, one with magnesium and one without. Which data should be collected to support this hypothesis?

- (1) height of the cotton plants in both fields
- (2) diameter of the cotton bolls in both fields
- (3) length of the growing season in both fields
- (4) color of the cotton bolls in both fields

2 To separate leaf pigments, a biologist should use

- (1) chromatography
- (2) dissection
- (3) an electronic balance
- (4) a dichotomous key

3 A food web is more stable than a food chain because a food web

- (1) transfers all of the producer energy to herbivores
- (2) reduces the number of niches in the ecosystem
- (3) includes alternative pathways for energy flow
- (4) includes more consumers than producers

4 Which sequence of terms is in the correct order from simplest to most complex?

- (1) cells → tissues → organs → organ systems
- (2) tissues → organisms → cells → organ systems
- (3) cells → tissues → organ systems → organs
- (4) organs → organisms → organ systems → cells

5 For which organic compounds must information be encoded in DNA for green plants to synthesize the other three compounds?

- (1) sugars
- (2) starches
- (3) fats
- (4) proteins

6 The diagram below represents the actions of two hormones in the human body.

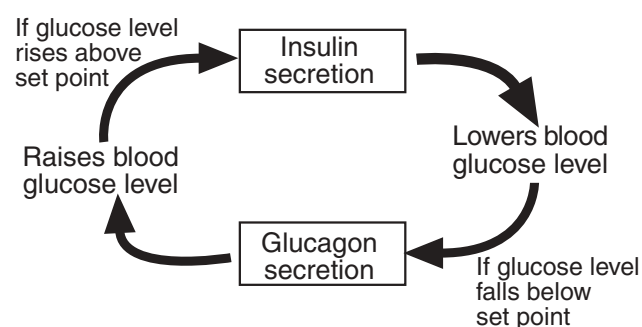

This diagram best illustrates

- (1) recombination
- (2) feedback
- (3) insertion
- (4) deletion

7 The pancreas is an organ connected to the digestive tract of humans by a duct (tube) through which digestive enzymes flow. These enzymes are important to the digestive system because they

- (1) form proteins needed in the stomach
- (2) form the acids that break down food
- (3) change food substances into molecules that can pass into the bloodstream and cells
- (4) change food materials into wastes that can be passed out of the body

8 While viewing a slide of rapidly moving sperm cells, a student concludes that these cells require a large amount of energy to maintain their activity. The organelles that most directly provide this energy are known as

- (1) vacuoles
- (2) ribosomes
- (3) chloroplasts
- (4) mitochondria

9 Meiosis and fertilization are important processes because they may most immediately result in

- (1) many body cells
- (2) immune responses
- (3) genetic variation
- (4) natural selection

10 In the diagram below, strands I and II represent portions of a DNA molecule.

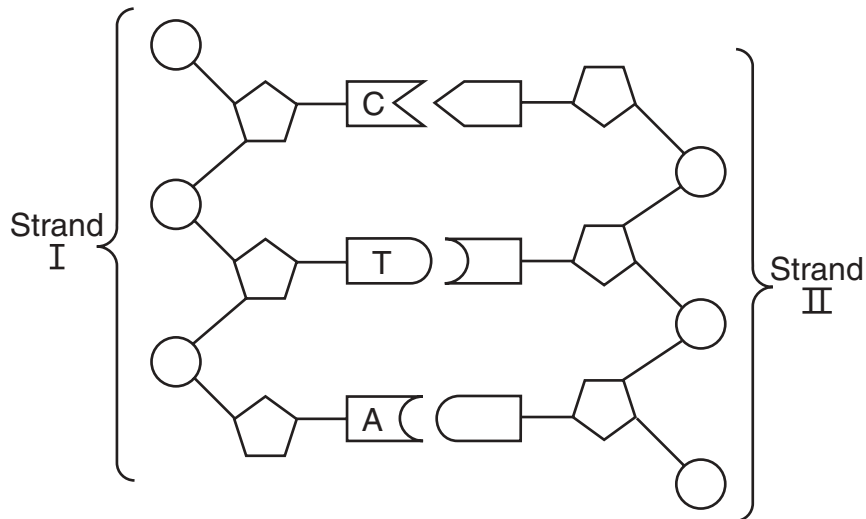

Strand II would normally include

- | | |
|---------|---------|
| (1) AGC | (3) TAC |
| (2) TCG | (4) GAT |

11 In Siamese cats, the fur on the ears, paws, tail, and face is usually black or brown, while the rest of the body fur is almost white. If a Siamese cat is kept indoors where it is warm, it may grow fur that is almost white on the ears, paws, tail, and face, while a Siamese cat that stays outside where it is cold, will grow fur that is quite dark on these areas. The best explanation for these changes in fur color is that

- (1) an environmental factor influences the expression of this inherited trait
- (2) the location of pigment-producing cells determines the DNA code of the genes
- (3) skin cells that produce pigments have a higher mutation rate than other cells
- (4) the gene for fur color is modified by interactions with the environment

12 After a series of cell divisions, an embryo develops different types of body cells such as muscle cells, nerve cells, and blood cells. This development occurs because

- (1) the genetic code changes as the cells divide
- (2) different segments of the genetic instructions are used to produce different types of cells
- (3) different genetic instructions are synthesized to meet the needs of new types of cells
- (4) some parts of the genetic materials are lost as a result of fertilization



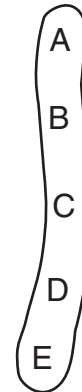

13 The letters in the diagram below represent genes on a particular chromosome.



Gene B contains the code for an enzyme that cannot be synthesized unless gene A is also active. Which statement best explains why this can occur?

- (1) A hereditary trait can be determined by more than one gene.
- (2) Genes are made up of double-stranded segments of DNA.
- (3) All the genes on a chromosome act to produce a single trait.
- (4) The first gene on each chromosome controls all the other genes on the chromosome.

14 Information related to the organisms found on Earth during various geological time periods is represented in the chart below.

Common Organisms					
	Time	4.6 (?) Billion Years Ago	600 Million Years Ago	200 Million Years Ago	60 Million Years Ago
	Era	Precambrian (Simple Multicellular Organisms and First Protists)	Paleozoic (Age of Amphibians, Fishes, and Invertebrates)	Mesozoic (Age of Reptiles)	Cenozoic (Age of Mammals)
	Past ————— Geologic Time ————— Present				

Which statement concerning the first appearance of the organisms over the time period represented in this chart is most likely correct?

- (1) Life on Earth has remained the same.
- (2) Life on Earth has changed from primitive organisms to more complex organisms.
- (3) Life on Earth began with complex organisms and changed to more complex organisms.
- (4) Life on Earth has changed rapidly.

15 In an area in Africa, temporary pools form where rivers flow during the rainy months. Some fish have developed the ability to use their ventral fins as “feet” to travel on land from one of these temporary pools to another. Other fish in these pools die when the pools dry up. What can be expected to happen in this area after many years?

- (1) The fish using ventral fins as “feet” will be present in increasing numbers.
- (2) “Feet” in the form of ventral fins will develop on all fish.
- (3) The fish using ventral fins as “feet” will develop real feet.
- (4) All of the varieties of fish will survive and produce many offspring.

16 Some stages in the development of an individual are listed below.

- (A) differentiation of cells into tissues
- (B) fertilization of egg by sperm
- (C) organ development
- (D) mitotic cell division of zygote

Which sequence represents the correct order of these stages?

- (1) A–B–C–D
- (2) B–C–A–D
- (3) D–B–C–A
- (4) B–D–A–C

17 The diagram below represents a cell process.

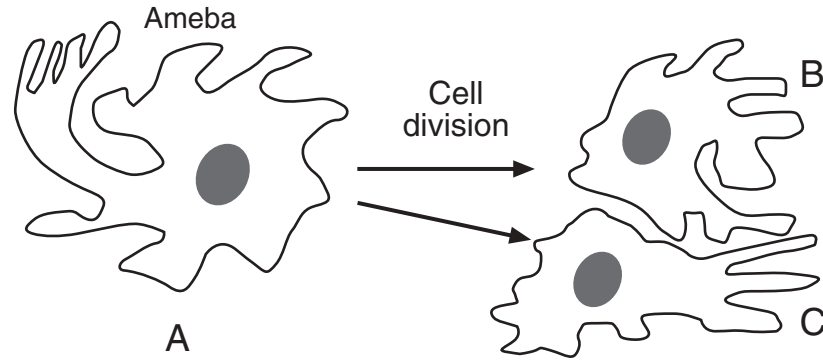

Which statement regarding this process is correct?

- (1) Cell *B* contains the same genetic information that cells *A* and *C* contain.
- (2) Cell *C* has DNA that is only 50% identical to cell *B*.
- (3) Cell *A* has DNA that is only 75% identical to cell *B*.
- (4) Cells *A*, *B*, and *C* contain completely different genetic information.

18 The diagram below shows the bones in the forelimbs of two different vertebrate species.

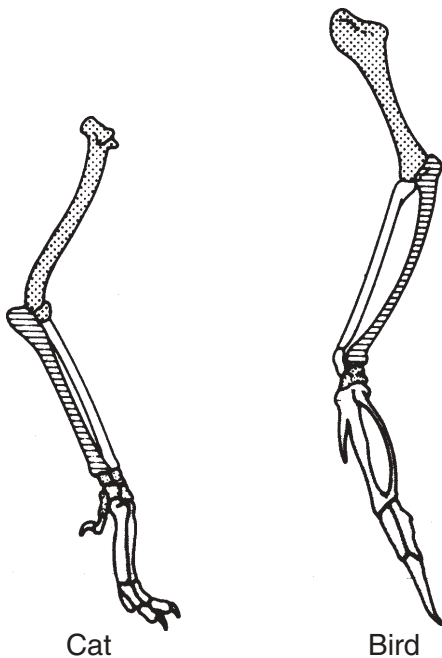

The position and structure of these bones could best be used to make inferences about the

- (1) food preferences of these vertebrate species
- (2) intelligence of these vertebrate species
- (3) history of these vertebrate species
- (4) reproductive behavior of these vertebrate species

19 Which statement does *not* correctly describe an adaptation of the human female reproductive system?

- (1) It produces gametes in ovaries.
- (2) It provides for external fertilization of an egg.
- (3) It provides for internal development of the embryo.
- (4) It removes excretions produced by the fetus.

20 Testes are adapted to produce

- (1) body cells involved in embryo formation
- (2) immature gametes that undergo mitosis
- (3) sperm cells that may be involved in fertilization
- (4) gametes with large food supplies that nourish a developing embryo

21 In nature, during a 24-hour period, green plants *continuously* use

- (1) carbon dioxide, only
- (2) both carbon dioxide and oxygen
- (3) oxygen, only
- (4) neither carbon dioxide nor oxygen

22 To remain healthy, organisms must be able to obtain materials, change the materials, move the materials around, and get rid of waste. These activities directly require

- (1) energy from ATP
- (2) the replication of DNA
- (3) nutrients from inorganic sources
- (4) manipulation of altered genes

23 Which statement describes all enzymes?

- (1) They control the transport of materials.
- (2) They provide energy for chemical reactions.
- (3) They affect the rate of chemical reactions.
- (4) They absorb oxygen from the environment.

24 Organisms undergo constant chemical changes as they maintain an internal balance known as

- (1) interdependence
- (2) homeostasis
- (3) synthesis
- (4) recombination

25 Which condition would most likely result in a human body being unable to defend itself against pathogens and cancerous cells?

- (1) a genetic tendency toward a disorder such as diabetes
- (2) a parasitic infestation of ringworm on the body
- (3) the production of antibodies in response to an infection in the body
- (4) the presence in the body of the virus that causes AIDS

26 Scientific studies have indicated that there is a higher percentage of allergies in babies fed formula containing cow's milk than in breast-fed babies. Which statement represents a valid inference made from these studies?

- (1) Milk from cows causes allergic reactions in all infants.
- (2) Breast feeding prevents all allergies from occurring.
- (3) There is no relationship between drinking cow's milk and having allergies.
- (4) Breast milk most likely contains fewer substances that trigger allergies.

27 The diagram below represents a model of a food pyramid.

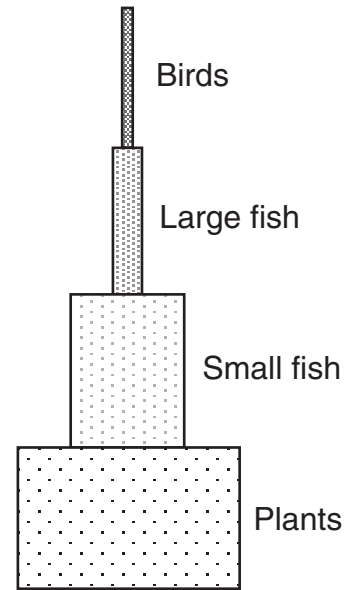

Which statement best describes what happens in this food pyramid?

- (1) More organisms die at higher levels than at lower levels, resulting in less mass at higher levels.
- (2) Energy is lost to the environment at each level, so less mass can be supported at each higher level.
- (3) When organisms die at higher levels, their remains sink to lower levels, increasing the mass of lower levels.
- (4) Organisms decay at each level, and thus less mass can be supported at succeeding higher levels.

28 Which energy transfer is *least* likely to be found in nature?

- (1) consumer to consumer
- (2) producer to consumer
- (3) host to parasite
- (4) predator to prey

29 Which ecosystem has a better chance of surviving when environmental conditions change over a long period of time?

- (1) one with a great deal of genetic diversity
- (2) one with plants and animals but no bacteria
- (3) one with animals and bacteria but no plants
- (4) one with little or no genetic diversity

30 The diagrams below show some changes in an environment over time.

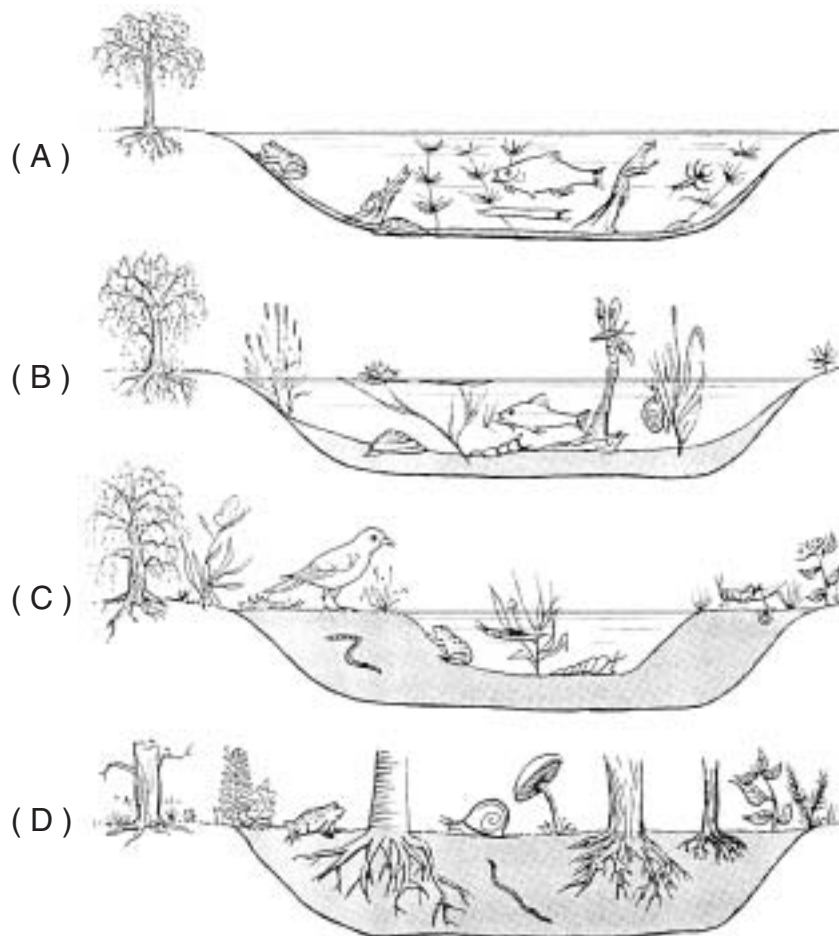

Which phrase best describes this sequence of diagrams?

- (1) the path of energy through a food web in a natural community
- (2) the altering of an ecosystem by a natural disaster
- (3) natural communities replacing each other in an orderly sequence
- (4) similarities between an aquatic ecosystem and a terrestrial ecosystem

31 Which factor is often responsible for the other three?

- (1) increase in levels of toxins in both water and air
- (2) increase in human population
- (3) increased poverty and malnutrition
- (4) increased depletion of finite resources

32 By causing atmospheric changes through activities such as polluting and careless harvesting, humans have

- (1) caused the destruction of habitats
- (2) affected global stability in a positive way
- (3) established equilibrium in ecosystems
- (4) replaced nonrenewable resources

33 The diagram below illustrates the relationships between organisms in an ecosystem.

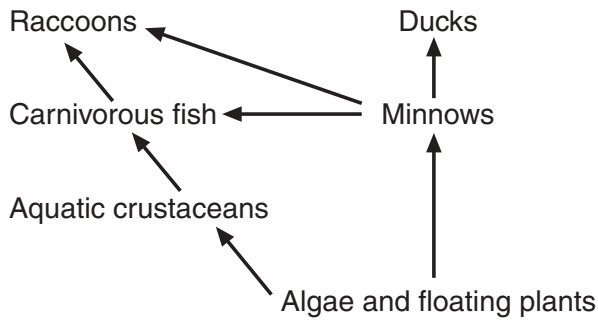

Which change would most likely reduce the population size of the carnivorous fish?

- (1) an increase in the autotroph populations
- (2) a decrease in the duck population
- (3) an increase in the raccoon population
- (4) a decrease in pathogens of carnivorous fish

34 Dumping raw sewage into a river will lead to a reduction in dissolved oxygen in the water. This reduction will most likely cause

- (1) an increase in all fish populations
- (2) a decrease in most aquatic animal populations
- (3) an increase in depth of the water
- (4) a decrease in water temperature

35 Which method of controlling populations of mosquitoes most likely involves the *least* risk of causing damage to the environment?

- (1) draining swamps where mosquitoes deposit eggs
- (2) spraying adult mosquitoes with pesticides from airplanes
- (3) releasing more predators of mosquitoes native to mosquito habitats
- (4) spraying oil on wet areas where mosquitoes breed

Part B

Answer all questions in this part.

Directions (36–63): For those questions that are followed by four choices, circle the number of the choice that best completes the statement or answers the question. For all other questions in this part, follow the directions given in the question and record your answers in the spaces provided.

36 A researcher needs information on antigen–antibody reactions. Searching for which phrase would best lead the researcher to information about these reactions?

- (1) protein synthesis
- (2) energy sources in nature
- (3) white blood cell activity
- (4) DNA replication

For Teacher Use Only

36

Base your answers to questions 37 and 38 on the table below and on your knowledge of biology.

Volunteer	Injected with Dead Chicken Pox Virus	Injected with Dead Mumps Virus	Injected with Distilled Water
A	X		
B		X	
C			X
D	X	X	

37 None of these volunteers ever had chicken pox. After the injection, there would most likely be antibodies to chicken pox in the bloodstream of

- (1) volunteers *A* and *D*, only
- (2) volunteers *A*, *B*, and *D*
- (3) volunteer *C*
- (4) volunteer *D*, only

37

38 Volunteers *A*, *B*, and *D* underwent a procedure known as

- (1) cloning
- (2) vaccination
- (3) electrophoresis
- (4) chromatography

38

39 The photograph below shows a microscopic view of the lower surface of a leaf.

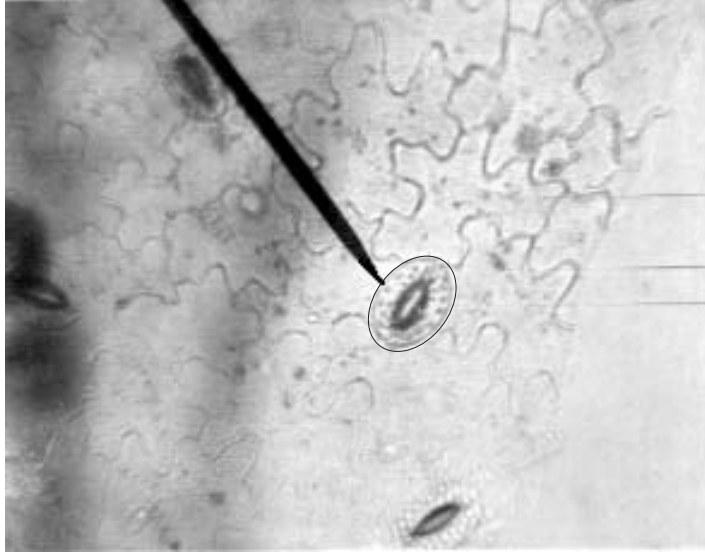

What is the main function of the cells indicated by the black pointer?

- (1) regulate the rate of gas exchange
- (2) store food for winter dormancy
- (3) undergo mitotic cell division
- (4) give support to the veins in the leaf

**For Teacher
Use Only**

39



Base your answers to questions 40 and 41 on the diagram below and on your knowledge of biology.

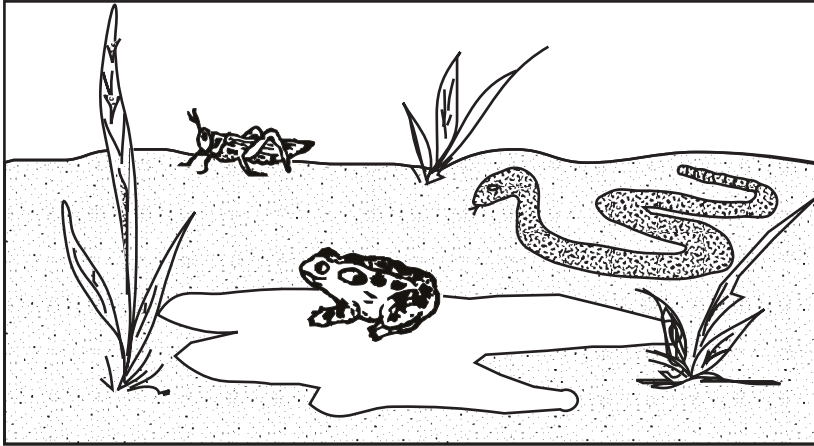

**For Teacher
Use Only**

40 Which organism carries out autotrophic nutrition?

- (1) frog
- (2) snake
- (3) plant
- (4) grasshopper

40

41 The base of an energy pyramid for this ecosystem would include a

- (1) frog
- (2) snake
- (3) plant
- (4) grasshopper

41

Base your answers to questions 42 through 46 on the information and data table below and on your knowledge of biology.

**For Teacher
Use Only**

A biology student performed an experiment to determine which of two species of single-celled organisms would survive best when cultured together in a certain environment. The student placed 10 organisms of each species into a large test tube. Throughout the experiment, the test tube was maintained at 30°C. After the test tube was set up, the population of each species was determined each day for 5 days. The data collected are shown in the table below.

Data Table

Day	Population	
	Species A	Species B
1	10	10
2	16	16
3	32	32
4	48	12
5	60	4

Directions (42–44): Using the information in the data table, construct a line graph on the grid on the next page, following the directions below.

42 Mark an appropriate scale on each labeled axis. [1]

43 Plot the data for species A on the grid. Surround each point with a small circle and connect the points. [1]



44 Plot the data for species B on the grid. Surround each point with a small triangle and connect the points. [1]



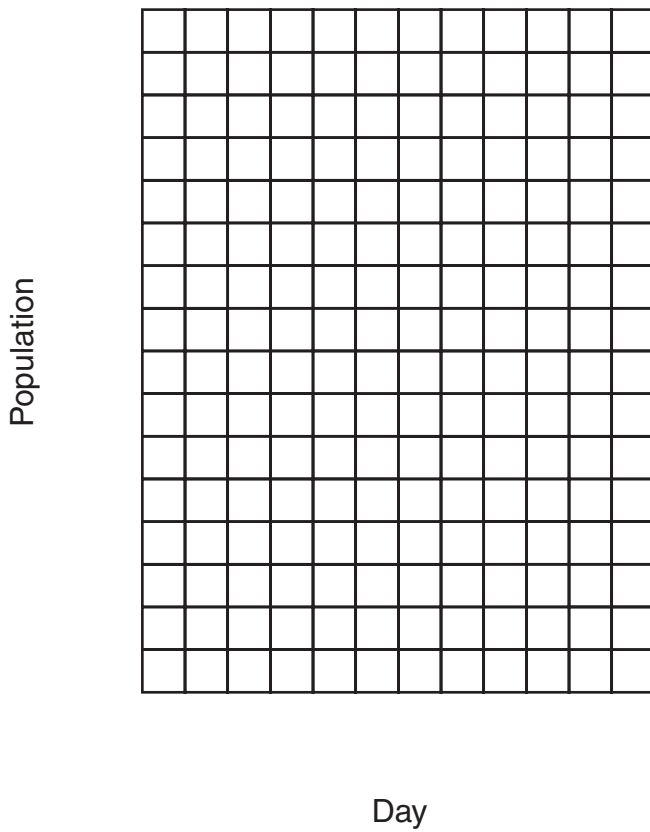

○ Species A
 △ Species B

**For Teacher
 Use Only**

42

43

44

45 Based on the daily counts, on which day did it first become evident that one species was better adapted than the other species for survival in the environment provided? [1]

45

46 The difference in the population sizes on the fifth day most likely resulted from

- (1) temperature changes
- (2) variations in light intensity
- (3) competition between species
- (4) the buildup of nitrogen gas

46

Base your answers to questions 47 through 49 on the information, diagram, and table below and on your knowledge of biology.

**For Teacher
Use Only**

A student wanted to test the hypothesis that rooting hormones will stimulate the production of new roots at a faster rate than would take place without rooting hormones. Two stem cuttings of equal length, similar to the one shown below, were taken from a rose, a begonia, and a geranium plant.



The cut end of one cutting from each plant was dipped into the hormone and then planted in wet sand. The other cutting from each plant was planted in wet sand without dipping it into the hormone. All cuttings were maintained in identical environmental conditions. At the end of 4 weeks, all the cuttings were removed from the sand and the lengths of the roots that had developed were measured. The results are summarized in the data table below.

Plant Cutting	Total Length of Roots in Centimeters	
	Treated with Hormone	Untreated
Begonia	1.50	1.00
Geranium	0.75	0.50
Rose	0.00	0.00

47 The effect of the rooting hormone on the production of new roots was most likely due to the influence of the hormone on the process of

- (1) photosynthesis
- (2) meiosis
- (3) mitosis
- (4) excretion

47

48 Describe *one* way the student could make the experiment more valid. [1]

48

49 What purpose did the untreated cuttings serve in this experiment? [1]

**For Teacher
Use Only**

49

Base your answers to questions 50 and 51 on the diagram below of sugar in a beaker of water and on your knowledge of biology.

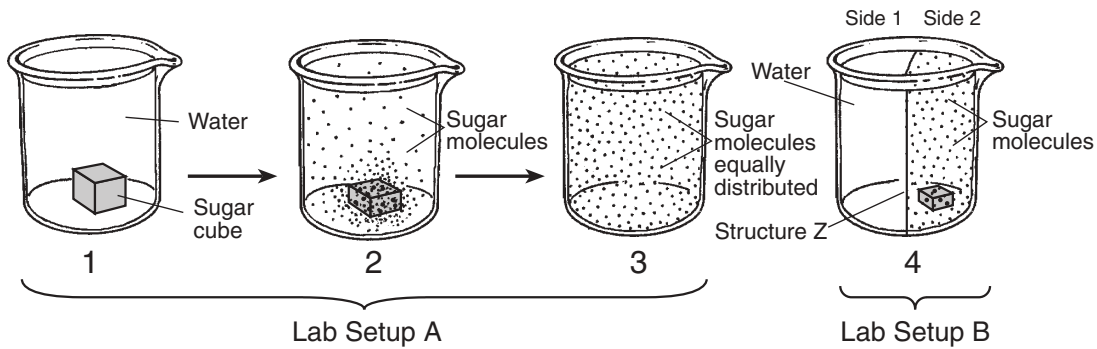

50 What process accounts for the change shown in lab setup A? [1]

50

51 In lab setup B, structure Z prevents the movement of sugar molecules into side 1. Which part of a living cell serves the same purpose as structure Z? [1]

51

Base your answers to questions 52 and 53 on the graph below and on your knowledge of biology. The graph shows the relative concentrations of different ions inside and outside of an animal cell.

**For Teacher
Use Only**

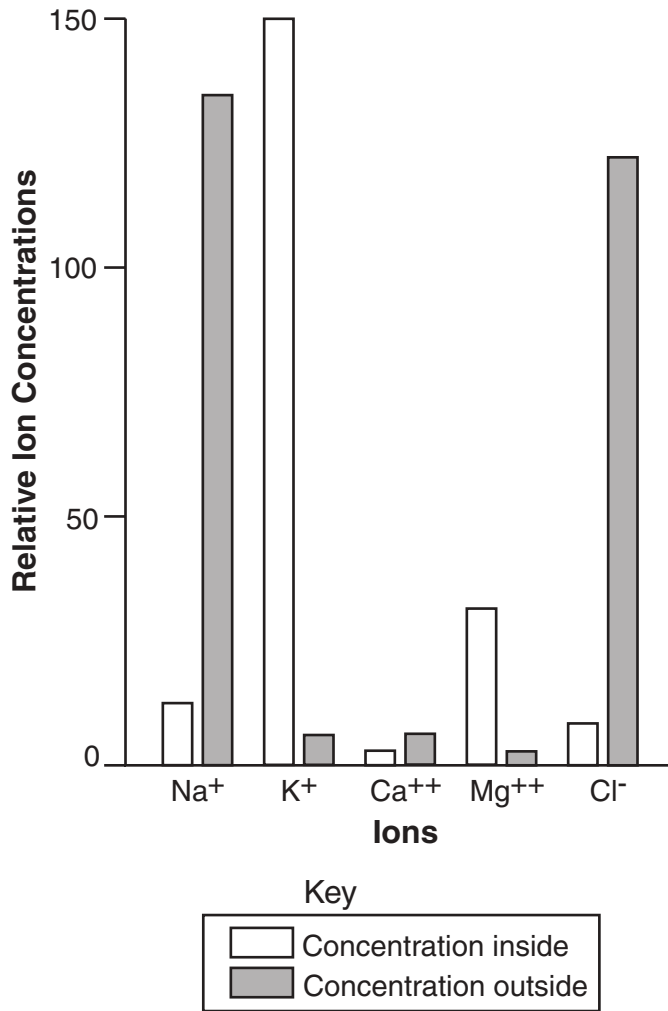

52 Write the symbol of the ion that is closest to equilibrium inside and outside of the cell. [1]

52

53 Name the process responsible for maintaining high concentrations of K⁺ ions inside the cell. [1]

53

54 The diagram below shows a biological process.

**For Teacher
Use Only**

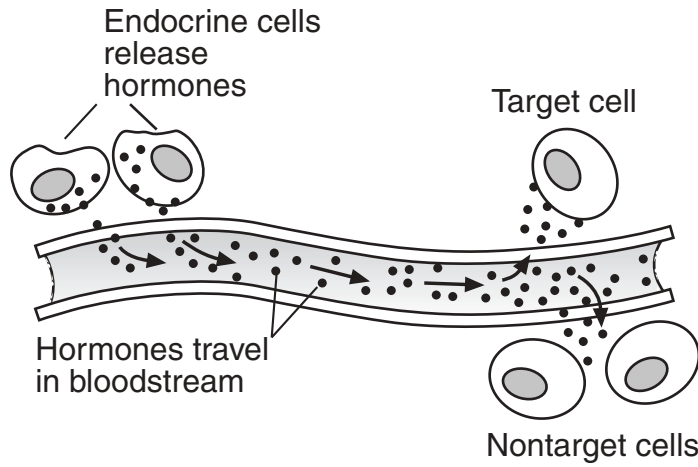

Explain why the hormones attach to the target cell and *not* to other cells in the diagram. [1]

54

55 The diagram below represents a technique used in biotechnology.

**For Teacher
Use Only**

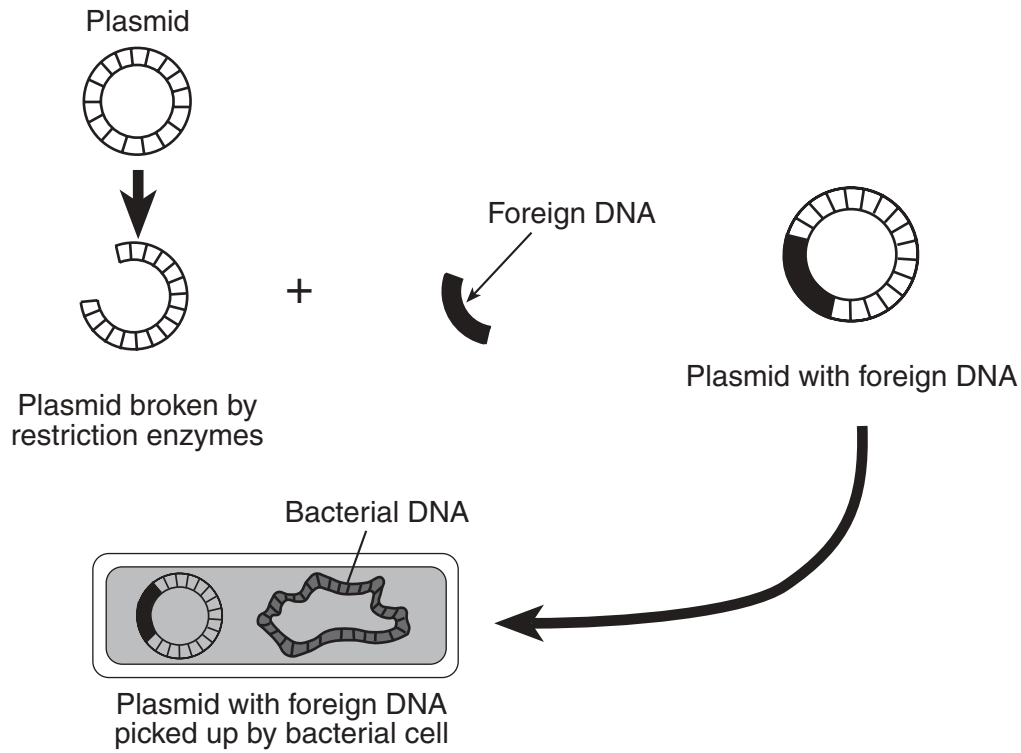

Name a specific substance that can be produced by this technique and state how humans have benefited from the production of this substance. [2]

55

Base your answers to questions 56 and 57 on the passage below and on your knowledge of biology.

**For Teacher
Use Only**

The Human Genome Project

For a number of years, scientists at Cold Spring Harbor Laboratory have been attempting to map every known human gene. By mapping, scientists mean that they are trying to find out on which of the 46 chromosomes each gene is located and exactly where on the chromosome the gene is located. By locating the exact positions of defective genes, scientists hope to cure diseases by replacing defective genes with normal ones, a technique known as gene therapy. Scientists can use specific enzymes to cut out the defective genes and insert the normal genes. They must be careful to use the enzyme that will splice out only the target gene, since different enzymes will cut DNA at different locations.

While the human genome project should eventually improve the health of humans, many people are skeptical and apprehensive, believing that gene therapy would be working against nature and would have religious, moral, legal, and ethical implications.

56 Using *one* specific example, explain why the human genome project is considered important. [1]

56

57 Explain why scientists must use only certain enzymes when inserting or removing a defective gene from a cell. [1]

57

58 Explain why, in a mammal, a mutation in a gamete may contribute to evolution while a mutation in a body cell will not. [1]

58

59 A certain chemical destroys bacteria that have thin cell walls. Bacteria with thick cell walls are not affected. Describe how the introduction of this chemical into a culture containing both types of bacteria could be used to illustrate the theory of natural selection. [1]

**For Teacher
Use Only**

59

60 The diagram below represents a woolly mammoth, a relative of the modern elephant. Woolly mammoths lived during the Ice Age and eventually became extinct.

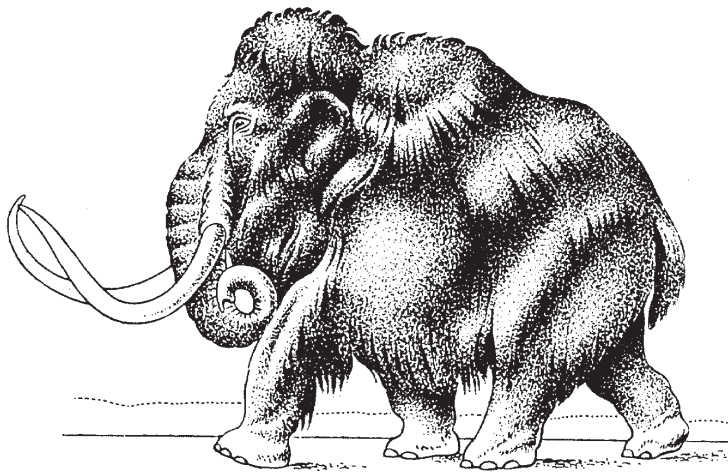

State *one* possible reason this species died out. [1]

60

61 An incomplete diagram of meiosis in the ovary of an animal is shown below.

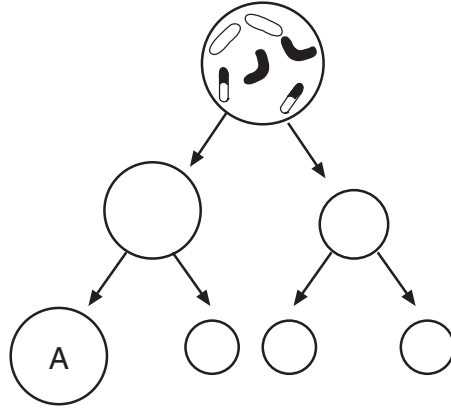

On the diagram below, draw in the chromosomes of cell A. Your drawing should show the usual result of the process of meiosis. [1]

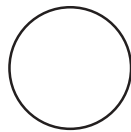

**For Teacher
Use Only**

61

62 The loss of ozone in the upper atmosphere results in an increased amount of ultraviolet light reaching Earth from the Sun. Explain how this increase may be harmful, other than contributing in a small way to global warming, to life on Earth. [1]

62

63 Recycling can extend the use of nonrenewable resources but can *not* restore them. Humans can restore renewable resources to reduce some negative effects of increased human consumption. Identify *one* resource that is renewable, and describe *one* specific way humans can restore this resource if it is being depleted. [2]

63

Part C

Answer all questions in this part.

Directions (64–78): Record your answers in the spaces provided in this examination booklet.

Base your answers to questions 64 and 65 on the information below and on your knowledge of biology.

Mountain lions and big horn sheep are part of the natural food web in the Sierra Nevada mountains. The Fish and Wildlife Service recently declared these sheep an endangered species. This action could lead to the shooting of mountain lions.

64 State *one* reason placing these sheep on an endangered species list could lead to the shooting of mountain lions where the sheep live. [1]

64

65 State *two* reasons some people would oppose the shooting of the mountain lions. [2]

(1) _____

(2) _____

65

Base your answers to questions 66 through 68 on the diagram below that represents a human enzyme and four types of molecules present in a solution in a flask.

Enzyme

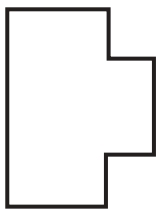

Molecules



A



B



C



D

66 Which molecule would most likely react with the enzyme? [1]

66

**For Teacher
Use Only**

67 Explain your answer to question 66. [1]

**For Teacher
Use Only**

67

68 State what would most likely happen to the rate of reaction if the temperature of the solution in the flask were increased gradually from 10°C to 30°C. [1]

68

69 A diagram of the human female reproductive system is shown below.

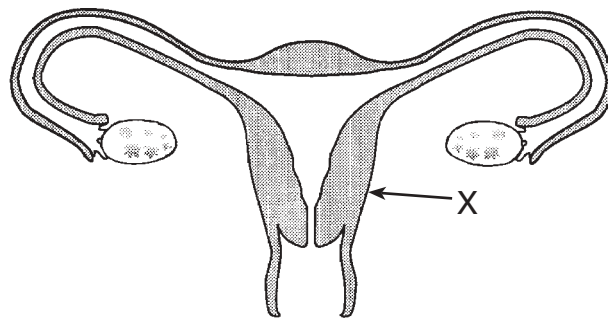

Identify the structure labeled X and explain how it helps to provide nutrition for a developing fetus. [2]

69

Base your answers to questions 70 through 72 on the food web shown below and on your knowledge of biology.

**For Teacher
Use Only**

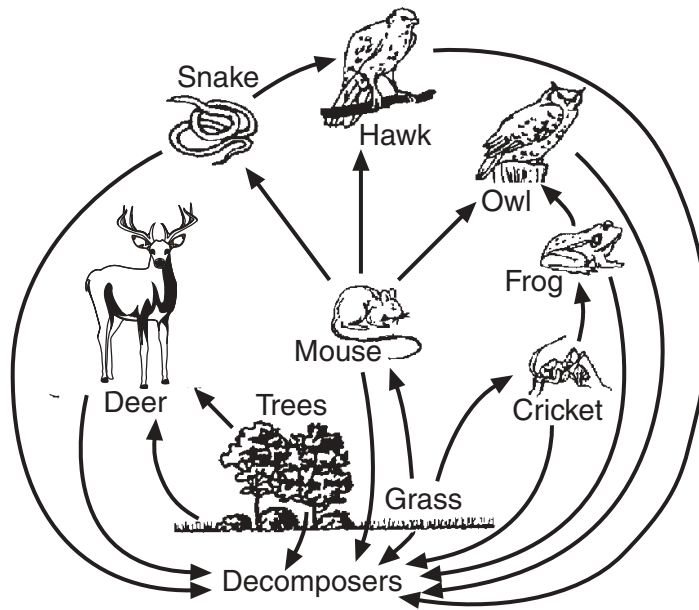

70 A pesticide is sprayed to kill the crickets. State *one* effect this spraying might have on the food web. [1]

70

71 What is the significance of the arrow between the trees and the deer in the food web? [1]

71

72 State the role of the decomposers in the food web. [1]

72

Base your answers to questions 73 through 76 on the information below.

Acid rain can have a pH between 1.5 and 5.0. The effect of acid rain on the environment depends on the pH of the rain and the characteristics of the environment. It appears that acid rain has a negative effect on plants. The scale below shows the pH of normal rain.

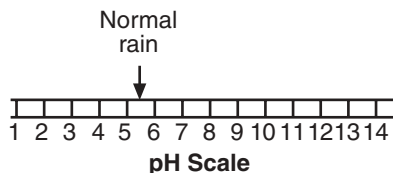

Provide the information requested below that should be included in a research plan to test the effect of pH on the early growth of bean plants in the laboratory.

73 State a hypothesis. [1]

73

74 Identify the independent variable. [1]

74

75 State *two* factors that should be kept constant. [2]

(1) _____

(2) _____

75

76 Construct a data table to organize the results. [1]

76

**For Teacher
Use Only**

Base your answers to questions 77 and 78 on the summary equations of two processes below and on your knowledge of biology.

**For Teacher
Use Only**

Photosynthesis



Respiration



77a Choose *one* of the processes.

b Identify the source of the energy in the process you chose. [1]

c Identify where the energy ends up at the completion of that process. [1]

77

78 State *one* reason *each* of the two processes is important for living things. [2]

Photosynthesis: _____

Respiration: _____

78

Tear Here

The University of the State of New York

REGENTS HIGH SCHOOL EXAMINATION

LIVING ENVIRONMENT

Tuesday, August 13, 2002 — 12:30 to 3:30 p.m., only

ANSWER SHEET

Student Sex: Female
 Male

Teacher

School Grade

Part	Maximum Score	Student's Score
A	35	_____
B	30	_____
C	20	_____
Total Raw Score (maximum Raw Score: 85)		<input type="text"/>
Final Score (from conversion chart)		<input type="text"/>
Raters' Initials		
Rater 1 Rater 2		

Record your answers to Part A on this answer sheet.

Part A

- | | | |
|----------|----------|----------|
| 1 | 13 | 25 |
| 2 | 14 | 26 |
| 3 | 15 | 27 |
| 4 | 16 | 28 |
| 5 | 17 | 29 |
| 6 | 18 | 30 |
| 7 | 19 | 31 |
| 8 | 20 | 32 |
| 9 | 21 | 33 |
| 10 | 22 | 34 |
| 11 | 23 | 35 |
| 12 | 24 | |

The declaration below must be signed when you have completed the examination.

I do hereby affirm, at the close of this examination, that I had no unlawful knowledge of the questions or answers prior to the examination and that I have neither given nor received assistance in answering any of the questions during the examination.

Signature

Tear Here

Tear Here

Tear Here