

LIVING ENVIRONMENT

The University of the State of New York
REGENTS HIGH SCHOOL EXAMINATION

LIVING ENVIRONMENT

Wednesday, June 16, 2010 — 1:15 to 4:15 p.m., only

Student Name _____

School Name _____

Print your name and the name of your school on the lines above. Then turn to the last page of this booklet, which is the answer sheet for Part A and Part B–1. Fold the last page along the perforations and, slowly and carefully, tear off the answer sheet. Then fill in the heading of your answer sheet.

You are to answer all questions in all parts of this examination. Write your answers to the Part A and Part B–1 multiple-choice questions on the separate answer sheet. Write your answers for the questions in Parts B–2, C, and D directly in this examination booklet. All answers should be written in pen, except for graphs and drawings, which should be done in pencil. You may use scrap paper to work out the answers to the questions, but be sure to record all your answers on the answer sheet and in this examination booklet.

When you have completed the examination, you must sign the statement printed on your separate answer sheet, indicating that you had no unlawful knowledge of the questions or answers prior to the examination and that you have neither given nor received assistance in answering any of the questions during the examination. Your answer sheet cannot be accepted if you fail to sign this declaration.

Notice...

A four-function or scientific calculator must be made available for you to use while taking this examination.

The use of any communications device is strictly prohibited when taking this examination. If you use any communications device, no matter how briefly, your examination will be invalidated and no score will be calculated for you.

DO NOT OPEN THIS EXAMINATION BOOKLET UNTIL THE SIGNAL IS GIVEN.

Part A

Answer all questions in this part. [30]

Directions (1–30): For *each* statement or question, write on your separate answer sheet the *number* of the word or expression that, of those given, best completes the statement or answers the question.

- Why is a mushroom considered a heterotroph?
 - It manufactures its own food.
 - It divides by mitosis.
 - It transforms light energy into chemical energy.
 - It obtains nutrients from its environment.
- Three days after an organism eats some meat, many of the organic molecules originally contained in the meat would be found in newly formed molecules of
 - glucose
 - protein
 - starch
 - oxygen
- Which body system is correctly paired with its function?
 - excretory—produces antibodies to fight disease-causing organisms
 - digestive—produces hormones for storage and insulation
 - circulatory—transports materials for energy release in body cells
 - respiratory—collects waste material for digestion
- Which statement best explains why some cells in the reproductive system only respond to certain hormones?
 - These cells have different DNA than the cells in other body systems.
 - These cells have specific types of receptors on their membranes.
 - Reproductive system cells could be harmed if they made contact with hormones from other body systems.
 - Cells associated with the female reproductive system only respond to the hormone testosterone.

- In the cell shown below, which lettered structure is responsible for the excretion of most cellular wastes?

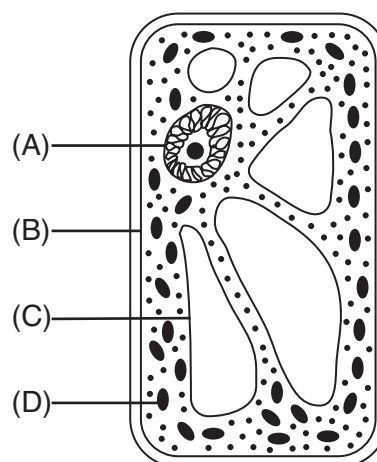

- A
 - B
 - C
 - D
- What is the main function of a vacuole in a cell?
 - storage
 - coordination
 - synthesis of molecules
 - release of energy
- If 15% of a DNA sample is made up of thymine, T, what percentage of the sample is made up of cytosine, C?
 - 15%
 - 35%
 - 70%
 - 85%
- Global warming has been linked to a *decrease* in the
 - size of the polar ice caps
 - temperature of Earth
 - rate of species extinction
 - rate of carbon dioxide production

9 Several structures are labeled in the diagram of a puppy shown below.

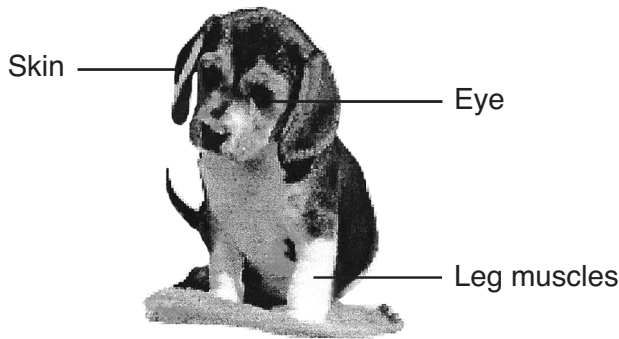

Every cell in each of these structures contains

- (1) equal amounts of ATP
 - (2) identical genetic information
 - (3) proteins that are all identical
 - (4) organelles for the synthesis of glucose
- 10 A characteristic that an organism exhibits during its lifetime will only affect the evolution of its species if the characteristic
- (1) results from isolation of the organism from the rest of the population
 - (2) is due to a genetic code that is present in the gametes of the organism
 - (3) decreases the number of genes in the body cells of the organism
 - (4) causes a change in the environment surrounding the organism
- 11 Agriculturists have developed some varieties of vegetables from common wild mustard plants, which reproduce sexually. Which statement best explains the development of these different varieties of vegetables?
- (1) Different varieties can develop from a single species as a result of the recombination of genetic information.
 - (2) Different species can develop from a single species as a result of the effect of similar environmental conditions.
 - (3) Mutations will occur in the genes of a species only if the environment changes.
 - (4) Variations in a species will increase when the rate of mitosis is decreased.

12 The diagram below represents a technique used in some molecular biology laboratories.

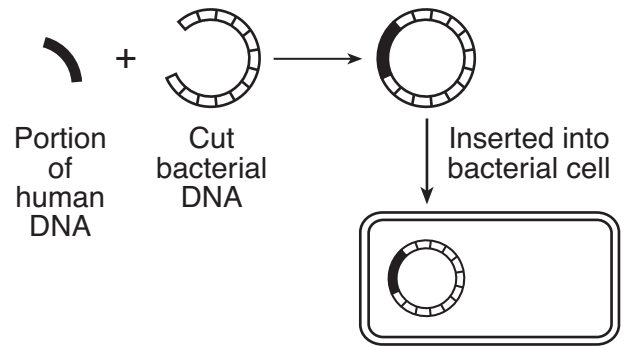

This technique is a type of

- (1) chromatography
 - (2) gel electrophoresis
 - (3) direct harvesting
 - (4) genetic engineering
- 13 A species of bird known as Bird of Paradise has been observed in the jungles of New Guinea. The males shake their bodies and sometimes hang upside down to show off their bright colors and long feathers to attract females. Females usually mate with the “flashiest” males. These observations can be used to support the concept that
- (1) unusual courtship behaviors lead to extinction
 - (2) some organisms are better adapted for asexual reproduction
 - (3) homeostasis in an organism is influenced by physical characteristics
 - (4) behaviors that lead to reproductive success have evolved

14 Which statement concerning the evolution of species *A*, *B*, *C*, *D*, and *E* is supported by the diagram below?

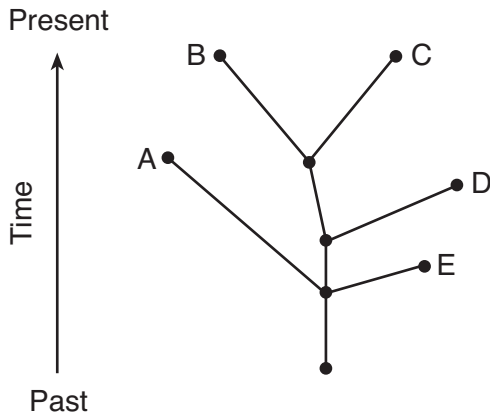

- (1) Species *B* and *C* can be found in today's environments.
- (2) Species *A* and *D* evolved from *E*.
- (3) Species *A* and *C* can still interbreed.
- (4) Species *A*, *B*, and *E* all evolved from a common ancestor and all are successful today.

15 The diagram below represents a process that occurs during human reproduction.



(Not drawn to scale)

The process represented by the arrow will ensure that the

- (1) zygote contains a complete set of genetic information
- (2) gametes contain a complete set of genetic information
- (3) zygote contains half of the genetic information
- (4) gametes contain half of the genetic information

16 Even though identical twins have the same genetic material, they may develop slightly different characteristics because

- (1) each twin receives different chromosomes from the egg
- (2) one twin may only have genes from the father
- (3) gene expression may be influenced by factors that switch genes on and off
- (4) a gene mutation may have occurred before the zygote divided

17 What normally happens immediately after fertilization in sexual reproduction?

- (1) specialization of cells to form a fetus from an egg
- (2) production of daughter cells having twice the number of chromosomes as the parent cell
- (3) production of daughter cells having half the number of chromosomes as the parent cell
- (4) division of cells resulting in the development of an embryo from a zygote

18 The human female reproductive system is represented in the diagram below.

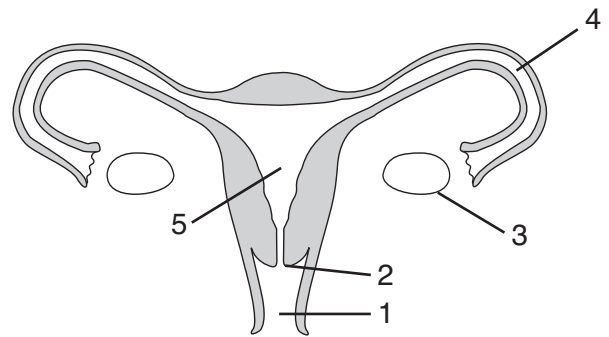

Production of gametes and support of the fetus normally occur in structures

- | | |
|-------------|-------------|
| (1) 1 and 2 | (3) 3 and 5 |
| (2) 2 and 4 | (4) 4 and 5 |

- 19 Essential materials needed for development are transported to a human fetus through the
- (1) reproductive hormones
 - (2) egg cell
 - (3) placenta
 - (4) ovaries
- 20 The failure to regulate the pH of the blood can affect the activity of
- (1) enzymes that clot blood
 - (2) red blood cells that make antibodies
 - (3) chlorophyll that carries oxygen in the blood
 - (4) DNA that controls starch digestion in the blood
- 21 Young birds that have been raised in isolation from members of their species build nests characteristic of their species. This suggests that the nest-building behavior is
- (1) genetically inherited from parents
 - (2) learned by watching members of their species
 - (3) a disadvantage to the survival of the species
 - (4) a direct result of the type of food the bird eats
- 22 Some people with spinal cord injuries do not sweat below the area of the injury. Without the ability to sweat, the human body temperature begins to rise. Which statement would best describe this situation?
- (1) Feedback mechanisms regulate blood sugar levels.
 - (2) Gene mutations are increased.
 - (3) Energy from ATP is not available.
 - (4) Dynamic equilibrium is disrupted.
- 23 Decomposers are necessary in an ecosystem because they
- (1) produce food for plants by the process of photosynthesis
 - (2) provide energy for plants by the process of decay
 - (3) can rapidly reproduce and evolve
 - (4) make inorganic materials available to plants
- 24 A manatee is a water-dwelling herbivore on the list of endangered species. If manatees were to become extinct, what would be the most likely result in the areas where they had lived?
- (1) The biodiversity of these areas would not be affected.
 - (2) Certain producer organisms would become more abundant in these areas.
 - (3) Other manatees would move into these areas and restore the population.
 - (4) Predators in these areas would occupy higher levels on the energy pyramid.
- 25 A serious threat to biodiversity is
- (1) habitat destruction
 - (2) maintenance of food chains
 - (3) competition within a species
 - (4) a stable population size
- 26 Which action will result in the greatest *decrease* in rain forest stability?
- (1) removing one species of plant for medicine
 - (2) harvesting nuts from some trees
 - (3) cutting down all the trees for lumber
 - (4) powering all homes with wind energy
- 27 One way that humans could have a positive impact on local environments is to
- (1) generate waste products as a result of technological advances
 - (2) use resources that are renewable
 - (3) increase planting large areas of one crop
 - (4) increase the use of pesticides
- 28 Which statement provides evidence that evolution is still occurring at the present time?
- (1) The extinction rate of species has decreased in the last 50 years.
 - (2) Many bird species and some butterfly species make annual migrations.
 - (3) New varieties of plant species appear more frequently in regions undergoing climatic change.
 - (4) Through cloning, the genetic makeup of organisms can be predicted.

29 The diagram below represents the various stages of ecological succession in New York State.

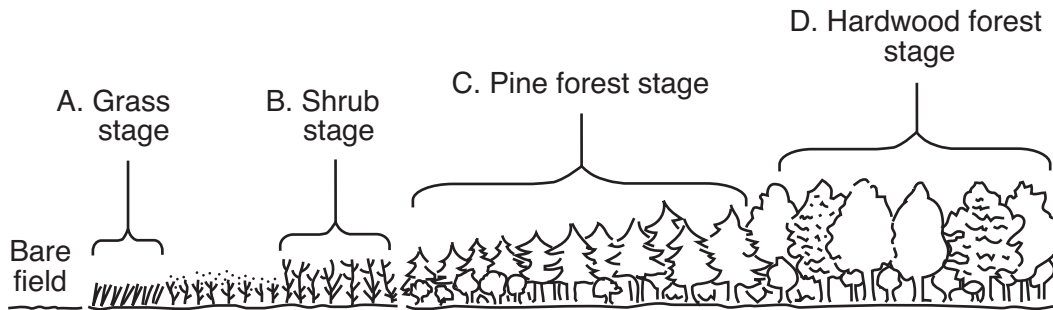

If the ecosystem is not altered, which stage would be the most stable?

- (1) grass
- (2) shrub
- (3) pine forest
- (4) hardwood forest

30 Because of an attractive tax rebate, a homeowner decides to replace an oil furnace heating system with expensive solar panels. The trade-offs involved in making this decision include

- (1) high cost of solar panels, reduced fuel costs, and lower taxes
 - (2) low cost of solar panels, increased fuel costs, and higher taxes
 - (3) increased use of fuel, more stable ecosystems, and less availability of solar radiation
 - (4) more air pollution, increased use of solar energy, and greater production of oil
-

Part B-1

Answer all questions in this part. [13]

Directions (31–43): For *each* statement or question, write on the separate answer sheet the *number* of the word or expression that, of those given, best completes the statement or answers the question.

- 31 A clear plastic ruler is placed across the middle of the field of view of a compound light microscope. A row of cells can be seen under low-power magnification (100 \times).

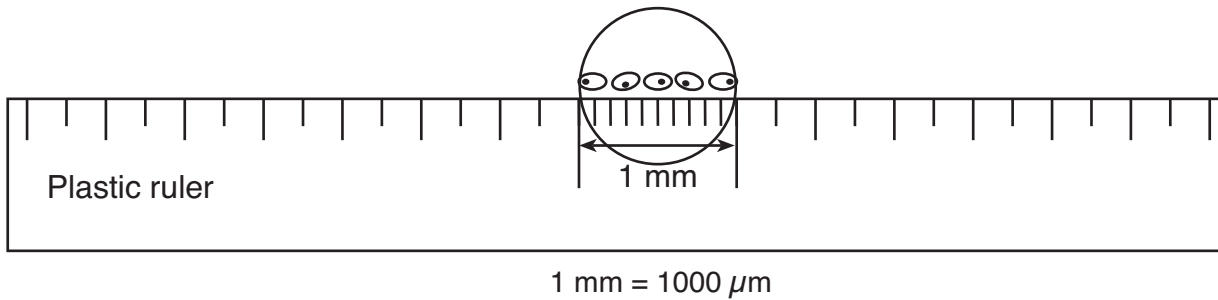

What is the average length of a single cell in micrometers (μ m)?

- (1) 10 μ m
(2) 100 μ m
(3) 200 μ m
(4) 2000 μ m
- 32 The graph below represents the populations of two different species in an ecosystem over a period of several years.

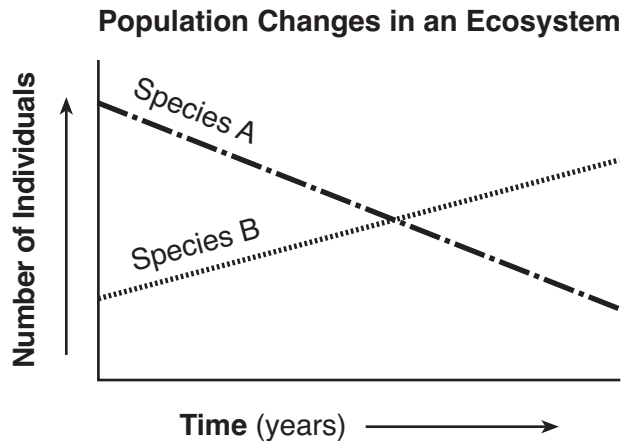

Which statement is a possible explanation for the changes shown?

- (1) Species A is better adapted to this environment.
(2) Species A is a predator of species B.
(3) Species B is better adapted to this environment.
(4) Species B is a parasite that has benefited species A.

33 A mineral supplement designed to prevent the flu was given to two groups of people during a scientific study. Dosages of the supplement were measured in milligrams per day, as shown in the table below.

Supplement Dosages

Group	Dosage (mg/day)
A	100
B	200

After 10 weeks, neither group reported a case of the flu. Which procedure would have made the outcome of this study more valid?

- (1) test only one group with 200 mg of the supplement
- (2) test the supplement on both groups for 5 weeks instead of 10 weeks
- (3) test a third group that receives 150 mg of the supplement
- (4) test a third group that does not receive the supplement

34 The diagram below shows a normal gene sequence and three mutated sequences of a segment of DNA.

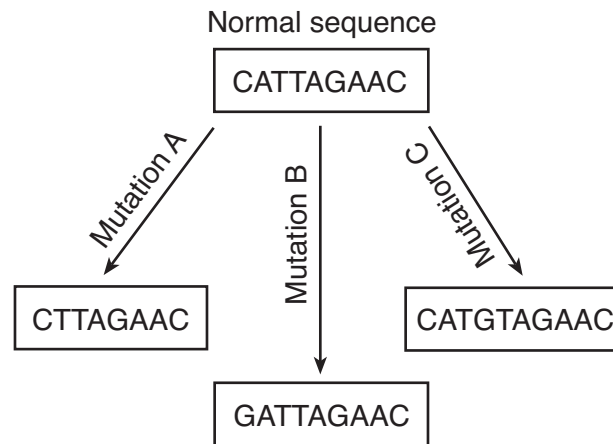

Which row in the chart below correctly identifies the cause of each type of mutation?

Row	Mutation A	Mutation B	Mutation C
(1)	deletion	substitution	insertion
(2)	insertion	substitution	deletion
(3)	insertion	deletion	substitution
(4)	deletion	insertion	substitution

Base your answers to questions 35 and 36 on the energy pyramid below and on your knowledge of biology.

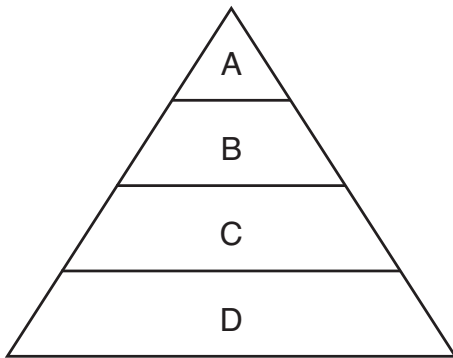

35 Which level includes organisms that receive their energy from level *B*?

- (1) *A*
- (2) *B*
- (3) *C*
- (4) *D*

36 Which level includes organisms that get their energy exclusively from a source other than the organisms in this ecosystem?

- (1) *A*
- (2) *B*
- (3) *C*
- (4) *D*

37 The chart below compares the size of three structures: a gene, a nucleus, and a chromosome.

Size	Structure
smallest in size	A
↓	B
greatest in size	C

Based on this information, structure *A* would most likely be a

- (1) chromosome that is part of structure *C*
- (2) chromosome that contains structures *B* and *C*
- (3) nucleus that contains both structure *B* and structure *A*
- (4) gene that is part of structure *B*

38 The diagram below shows molecules represented by X both outside and inside of a cell.

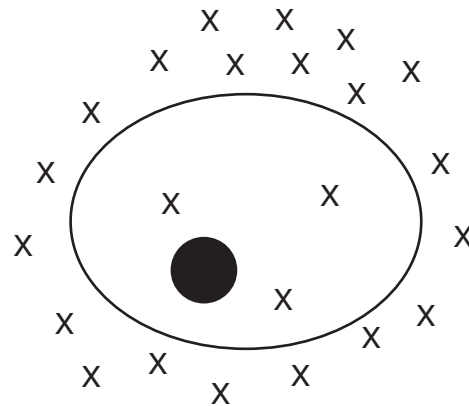

A process that would result in the movement of these molecules out of the cell requires the use of

- (1) DNA
- (2) ATP
- (3) antigens
- (4) antibodies

39 Which statement most accurately predicts what would happen in the aquarium shown below if it were tightly covered and maintained in natural light for one month?

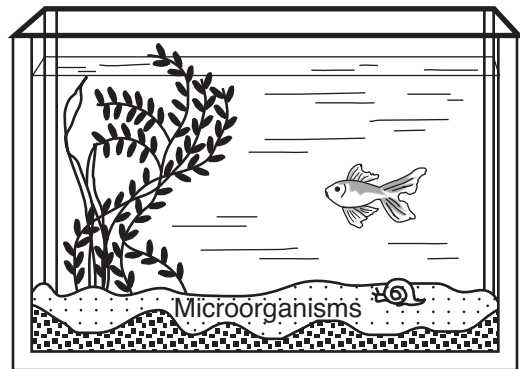

- (1) The water temperature would rapidly decrease.
- (2) The process of respiration in the snail would decrease.
- (3) The rate of reproduction of the fish would be affected.
- (4) The organisms would probably survive because materials would cycle.

40 The data table below shows an effect of secondhand smoke on the birth weight of babies born to husbands and wives living together during pregnancy.

Effect of Secondhand Smoke on Birth Weight

	Wife: Nonsmoker Husband: Nonsmoker	Wife: Nonsmoker Husband: Smoker
Number of Couples	837	529
Average Weight of Baby at Birth	3.2 kg	2.9 kg

Based on these data, a reasonable conclusion that can be drawn about secondhand smoke during pregnancy is that secondhand smoke

- (1) is unable to pass from the mother to the fetus
- (2) slows the growth of the fetus
- (3) causes mutations in cells of the ovaries
- (4) blocks the receptors on antibody cells

41 A limiting factor unique to a field planted with corn year after year is most likely

- (1) temperature
- (2) sunlight
- (3) water
- (4) soil nutrients

Base your answers to questions 42 and 43 on the information below and on your knowledge of biology.

After the Aswan High Dam was built on the Nile River, the rate of parasitic blood-fluke infection doubled in the human population near the dam. As a result of building the dam, the flow of the Nile changed. This changed the habitat, which resulted in an increase in its population of a certain aquatic snail. The snails, which were infected, released larvae of the fluke. These larvae then infected humans.

42 This situation best illustrates that

- (1) the influence of humans on a natural system is always negative in the long term
- (2) the influence of humans on a natural system can have unpredictable negative impacts
- (3) human alteration of an ecosystem does not need to be studied to avoid ecological disaster
- (4) human alteration of an ecosystem will cause pollution and loss of finite resources

43 The role of the snail may be described as a

- (1) host
 - (2) parasite
 - (3) producer
 - (4) decomposer
-

Part B-2

Answer all questions in this part. [12]

Directions (44–55): For those questions that are followed by four choices, circle the *number* preceding the choice that, of those given, best completes the statement or answers the question. For all other questions in this part, follow the directions given in the question and record your answers in the spaces provided.

44 The table below shows the abundance of some greenhouse gases in the atmosphere.

Abundance of Some Atmospheric Greenhouse Gases

Greenhouse Gases	Abundance (%)
carbon dioxide (CO ₂)	99.438
methane (CH ₄)	0.471
nitrous oxide (N ₂ O)	0.084
other gases (CFCs, etc.)	0.007
Total	100.000

Identify the most abundant greenhouse gas and state *one* human activity that is a source of this gas. [1]

Greenhouse gas: _____

**For Teacher
Use Only**

44

45 The United States government does not allow travelers from foreign countries to bring plants, fruits, vegetables, animals, or other living organisms into this country. State *one* biological reason for keeping these out of the United States. [1]

45

Base your answers to questions 46 through 49 on the information and data table below and on your knowledge of biology.

**For Teacher
Use Only**

Birds colliding with aircraft either on the ground or in the air create problems for the Air Force. An organization known as BASH (Bird Aircraft Strike Hazard) studied the impact of birds colliding with aircraft. In 2001, there were 3854 bird collisions reported at a total cost to the Air Force of over 31 million dollars in damage—approximately eight thousand dollars per collision. August, September, and October were the busiest months with 1442 collisions. Nearly 50% of all these collisions occurred in the airfield environment, an environment that can most easily be controlled.

The top five species of birds involved in these collisions are listed in the data table below.

Top Five Bird Species Involved in Collisions in 2001

Type of Bird	Number of Collisions
American mourning dove (species A)	123
horned lark (species B)	100
barn swallow (species C)	83
American cliff swallow (species D)	55
American robin (species E)	55

Source of data: Bird Aircraft Strike Hazard by Matt Granger, <http://www.find.articles.com>

Directions (46–47): Using the information in the data table, construct a bar graph on the grid, following the directions below.

**For Teacher
Use Only**

46 Mark an appropriate scale on the axis labeled “Number of Collisions.” [1]

47 Construct vertical bars to represent the data. Shade in each bar. [1]

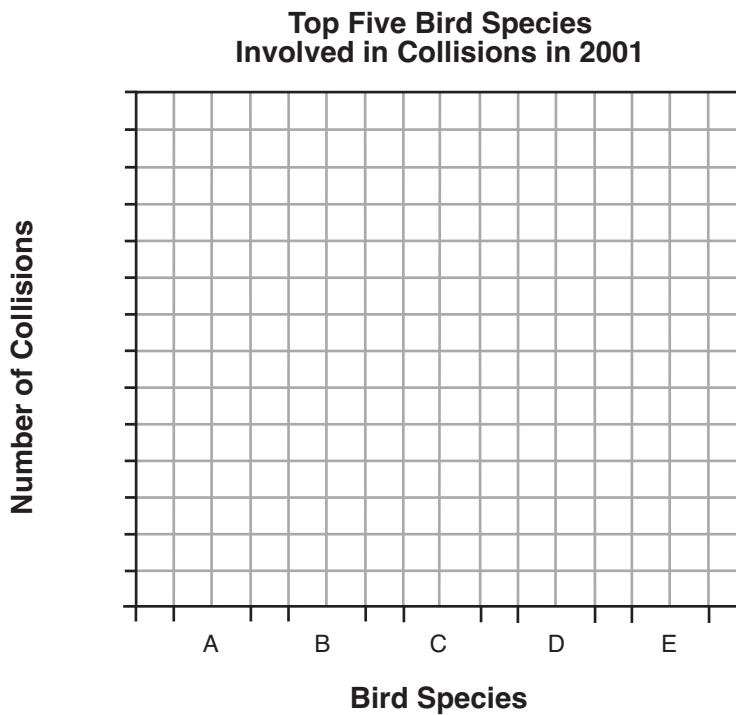

46

47

48 Is the problem with birds and aircraft limited to birds living on or near airport grounds? Support your answer using information from the passage. [1]

48

49 State *one* possible reason that the greatest number of bird collisions occurs during August, September, and October. [1]

49

Base your answers to questions 50 through 53 on the information below and on your knowledge of biology.

**For Teacher
Use Only**

The Control of Transpiration

Plants normally lose water from openings (stomates) in their leaves. The water loss typically occurs during daylight hours when plants are exposed to the Sun. This water loss, known as transpiration, is both beneficial and harmful to plants.

Scientists believe wind and high temperatures increase the rate of transpiration, but the size of each stomate opening can be regulated. Reducing the size of the openings during drought conditions may help reduce the dehydration and wilting that would otherwise occur.

A leaf may lose more than its own weight in water each day. Transpiration also lowers the internal temperature of the leaf as water evaporates. On hot days, temperatures in the leaves may be from 3° to 15°C cooler than the outside air. With stomates open, vital gases may be exchanged between the leaf tissues and the outside environment.

Researchers have also found many plants that use another response when leaf temperatures rise. Special molecules known as heat shock proteins are produced by plant cells and help to hold enzymes in their functional shapes.

50 State *one* way transpiration is beneficial to plants. [1]

50

51 Identify *two* of the “vital gases” that are exchanged between leaf tissues and the outside environment. [1]

_____ and _____

51

52 Identify the specific leaf structures that regulate the opening and closing of stomates. [1]

52

53 Explain why it is important for plants to “hold enzymes in their functional shapes.” [1]

53

54 The graph below shows the growth of a population of coyotes in a wilderness area.

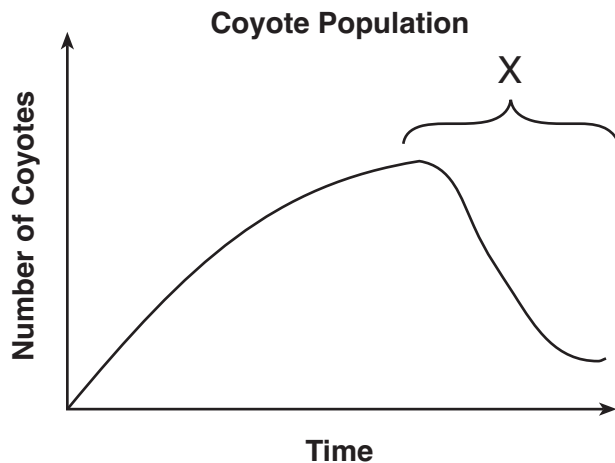

State *one* possible cause for the population decrease at X. [1]

**For Teacher
Use Only**

54

55 The information in the chart below represents the sex chromosome arrangement in humans and birds. Sex chromosomes contain genes involved in sex determination.

Sex Chromosomes in Animals

Animal	Female	Male
humans	XX	XY
birds	ZW	ZZ

In humans, it is the male gamete that is responsible for determining the sex of the offspring. Identify which type of gamete determines the sex of the offspring in birds. Support your answer. [1]

Type of Gamete: _____

55

Part C

Answer all questions in this part. [17]

Directions (56–64): Record your answers in the spaces provided in this examination booklet.

Base your answer to question 56 on the information below and on your knowledge of biology.

**For Teacher
Use Only**

Help for Aging Memories

As aging occurs, the ability to form memories begins to decrease. Research has shown that an increase in the production of a certain molecule, BDNF, seems to restore the processes involved in storing memories. BDNF is found in the central nervous system and seems to be important in maintaining nerve cell health. Researchers are testing a new drug that seems to increase the production of BDNF.

56 Design an experiment to test the effectiveness of the new drug to increase the production of BDNF in the brains of rats. In your answer, be sure to:

- state the hypothesis your experiment will test [1]
- describe how the control group will be treated differently from the experimental group [1]
- identify *two* factors that must be kept the same in both the experimental and control groups [1]
- identify the dependent variable in your experiment [1]

56

Base your answers to questions 57 through 59 on the information below and on your knowledge of biology.

Rabbits eat plants and in turn are eaten by predators such as foxes and wolves. A population of rabbits is found in which a few have a genetic trait that gives them much better than average leg strength.

57 Predict how the frequency of the trait for above average leg strength would be expected to change in the population over time. Explain your prediction. [1]

57

58 State what is likely to happen to the rabbits in the population that do *not* have the trait for above average leg strength. [1]

58

59 It was later discovered that the rabbits born with the trait for above average leg strength also inherited the trait for poor eyesight. Taking into account this new information, explain how your predictions would change. Support your answer. [1]

59

**For Teacher
Use Only**

Base your answer to question 60 on the information below and on your knowledge of biology.

Bacterial resistance to antibiotic treatment is becoming an increasing problem for the medical community. It is estimated that 70% of bacteria that cause infections in hospitals are resistant to at least one of the drugs used for treatment. Dangerous strains of tuberculosis (TB) have emerged that are resistant to several major antibiotic drugs. While drug-resistant TB is generally treatable, it requires much longer treatments with several antibiotics that are very expensive.

- 60 Explain the loss of effectiveness of antibiotic drugs. In your explanation, be sure to:
- identify the genetic event that resulted in the original antibiotic resistance in some strains of bacteria [1]
 - explain how the overuse of antibiotics can increase bacterial resistance [1]

60

Base your answers to questions 61 and 62 on the information below and on your knowledge of biology.

The average life expectancy of humans in the United States increased from 63.3 years in 1943 to 77.6 years in 2003. This, combined with other factors, has led to an increase in population.

- 61 State *one* factor that contributed to the increase in life expectancy in the United States. [1]

61

- 62 State *one* way the increase in population affects other species. [1]

62

63 The diagram below represents a cell found in some complex organisms. The enlarged section represents an organelle, labeled X, found in this cell.

**For Teacher
Use Only**

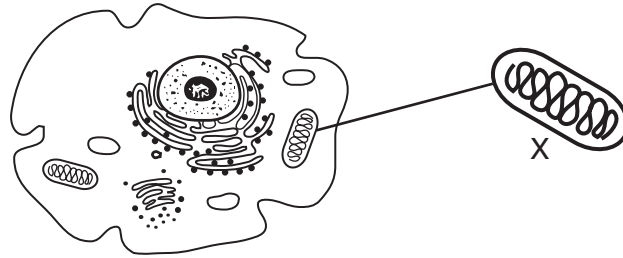

Describe the function of organelle X and explain how it is important to the survival of the cell. In your answer, be sure to:

- identify organelle X [1]
- state the process that this organelle performs [1]
- identify the *two* raw materials that are needed for this process to occur [1]
- identify *one* molecule produced by this organelle and explain why it is important to the organism [2]

63



Base your answer to question 64 on the passage below and on your knowledge of biology.

**For Teacher
Use Only**

The Arctic National Wildlife Refuge

The Arctic National Wildlife Refuge (ANWR) in Alaska is the last great wilderness in America. Many migratory animals stop there to feed and rest. This region also supports an abundance of wildlife, including various types of vegetation, herbivores such as musk oxen and reindeer, and carnivores such as polar bears and wolves.

64 Wolves often hunt reindeer for food. State the effect on the size of the wolf population if the amount of vegetation were to drop suddenly. Support your answer. [1]

64

Part D

Answer all questions in this part. [13]

Directions (65–77): For those questions that are followed by four choices, circle the *number* of the choice that, of those given, best completes the statement or answers the question. For all other questions in this part, follow the directions given in the question and record your answers in the spaces provided.

65 The amino acid sequences of three species shown below were determined in an investigation of evolutionary relationships.

Species A: Val His Leu Ser Pro Val Glu
Species B: Val His Leu Cys Pro Val Glu
Species C: Val His Thr Ser Pro Glu Glu

Based on these data, which *two* species are most closely related? Support your answer. [1]

**For Teacher
Use Only**

65

66 A student carried out a lab activity where she was asked to squeeze a clothespin as many times as she could in one minute and record that number. She immediately tried the same activity again, thinking she could do better the second time, but the number was lower. She immediately tried again, but the number was lower still.

State *one* reason why she continued to get lower numbers, even though she tried to increase the number of squeezes several times. [1]

66

67 A laboratory setup using an artificial cell made from dialysis tubing is shown in the diagram below.

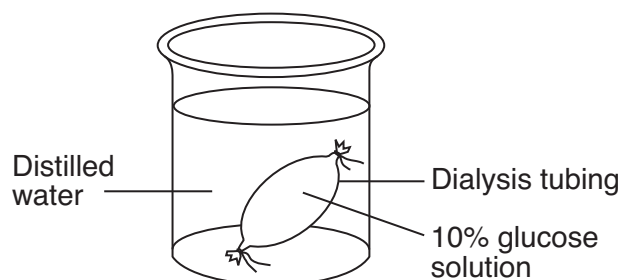

Identify the process that would most likely be responsible for the movement of glucose from inside the artificial cell to the solution outside of the cell. [1]

67

Base your answers to questions 68 through 71 on the information below and on your knowledge of biology.

**For Teacher
Use Only**

Scientists attempted to determine the evolutionary relationships between three different plant species, A, B, and C. In order to do this, they examined the stems and DNA of these species. Diagram 1 represents a microscopic view of the cross sections of the stems of these three species. DNA was extracted from all three species and analyzed using gel electrophoresis. The results are shown in diagram 2. Based on the data they collected, they drew diagram 3 to represent the possible evolutionary relationships.

Diagram 1

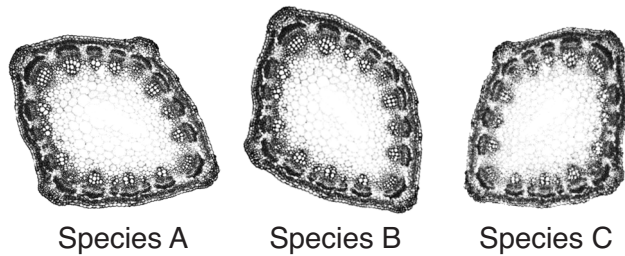

Diagram 2

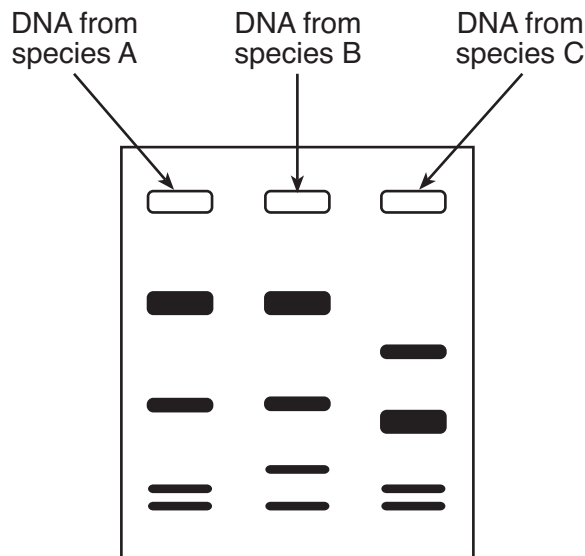
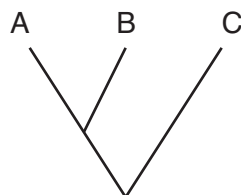

Diagram 3

**Possible Evolutionary Relationships
Between Species A, B, and C**



68 State why the evolutionary relationships shown in diagram 3 are *not* supported by the data provided by the stem cross sections in diagram 1. [1]

**For Teacher
Use Only**

68

69 Explain how the DNA banding pattern in diagram 2 supports the evolutionary relationships between the species shown in diagram 3. [1]

69

70 This technique used to analyze DNA involves the

- (1) synthesis of new DNA strands from subunits
- (2) separation of DNA fragments on the basis of size
- (3) production of genetically engineered DNA molecules
- (4) removal of defective genes from DNA

70

71 Explain why information obtained through DNA analysis is a more reliable indicator of evolutionary relationships than observations of stem cross sections with a microscope. [1]

71

Base your answers to questions 72 through 74 on the information below and on your knowledge of biology.

**For Teacher
Use Only**

A wet-mount slide of red onion cells is studied using a compound light microscope. A drawing of one of the cells as seen under high power is shown below.

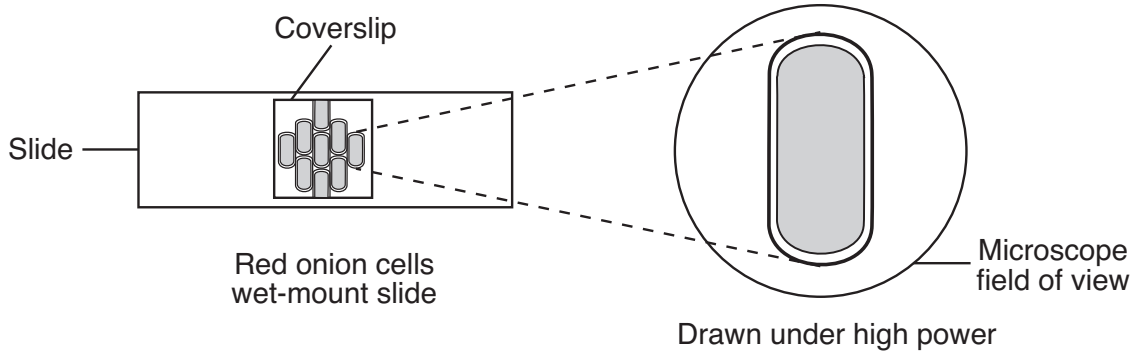

72 On the diagram below, label the location of each of the cell structures listed. [1]

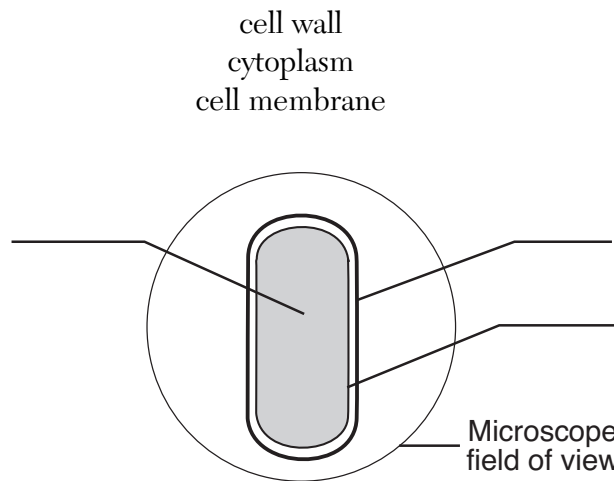

72

73 Describe the proper way to add a saltwater solution to the cells without removing the coverslip. [1]

73

74 In the space below, sketch how the cell would look after the saltwater solution is added to it. [1]

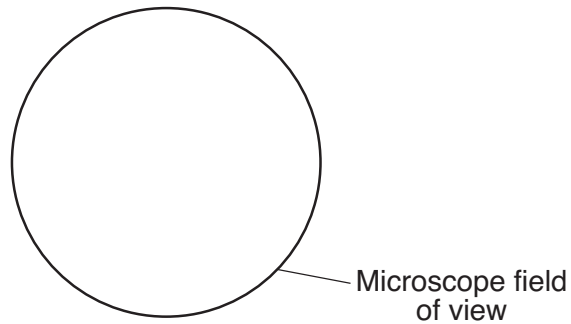

**For Teacher
Use Only**

74

75 A student added an enzyme to a test tube containing a sample of DNA. After a period of time, analysis of the DNA sample indicated it was now broken into three segments. The purpose of the enzyme was most likely to

- (1) cut the DNA at a specific location
- (2) move the DNA to a different organism
- (3) copy the DNA for protein synthesis
- (4) alter the DNA sequence in the segment

75

Base your answers to questions 76 and 77 on the diagram below and on your knowledge of biology. The diagram shows the heads of four different species of Galapagos Islands finches.

**For Teacher
Use Only**

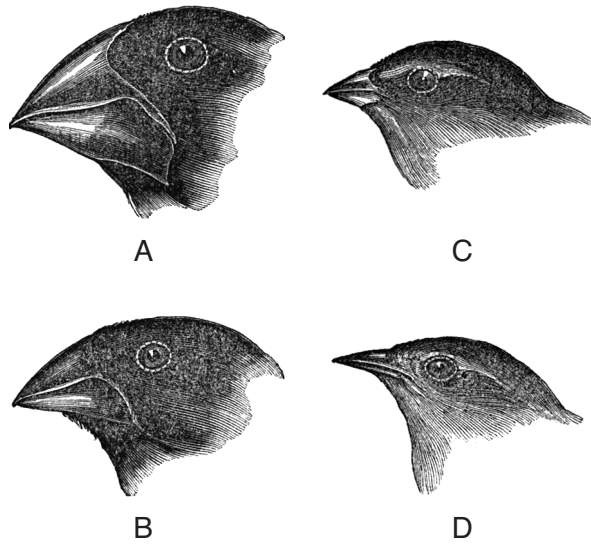

Source: <http://Darwin-online.org>

76 The four different types of beaks shown are most likely the result of

- (1) gene manipulation
- (2) natural selection
- (3) unchanging environmental conditions
- (4) patterns of behavior learned from parents

76

77 Scientists observed that when two closely related species of predatory birds live in different areas, they seek prey early in the morning. However, when their territories overlap, one species hunts at night and the other hunts in the morning. When these two species live in the same area, they apparently modify their

- (1) habitat
 - (2) niche
 - (3) ecosystem
 - (4) biodiversity
-

77

Tear Here

The University of the State of New York

REGENTS HIGH SCHOOL EXAMINATION

LIVING ENVIRONMENT

Wednesday, June 16, 2010 — 1:15 to 4:15 p.m., only

ANSWER SHEET

Female

Student Sex: Male

Teacher

School Grade

Part	Maximum Score	Student's Score
A	30	
B-1	13	
B-2	12	
C	17	
D	13	
Total Raw Score (maximum Raw Score: 85)		<input type="text"/>
Final Score (from conversion chart)		<input type="text"/>
Raters' Initials		
Rater 1		Rater 2

Record your answers to Part A and Part B-1 on this answer sheet.

Part A

- | | | |
|----------|----------|----------|
| 1 | 11 | 21 |
| 2 | 12 | 22 |
| 3 | 13 | 23 |
| 4 | 14 | 24 |
| 5 | 15 | 25 |
| 6 | 16 | 26 |
| 7 | 17 | 27 |
| 8 | 18 | 28 |
| 9 | 19 | 29 |
| 10 | 20 | 30 |

Part A Score

Part B-1

- | | |
|----------|----------|
| 31 | 38 |
| 32 | 39 |
| 33 | 40 |
| 34 | 41 |
| 35 | 42 |
| 36 | 43 |
| 37 | |

Part B-1 Score

The declaration below must be signed when you have completed the examination.

I do hereby affirm, at the close of this examination, that I had no unlawful knowledge of the questions or answers prior to the examination and that I have neither given nor received assistance in answering any of the questions during the examination.

Signature

Tear Here

LIVING ENVIRONMENT

Tear Here

Tear Here

Printed on Recycled Paper

LIVING ENVIRONMENT