

# Large-Type Edition

The University of the State of New York  
REGENTS HIGH SCHOOL EXAMINATION

# LIVING ENVIRONMENT

## v202

Student Name \_\_\_\_\_

School Name \_\_\_\_\_

The possession or use of any communications device is strictly prohibited when taking this examination. If you have or use any communications device, no matter how briefly, your examination will be invalidated and no score will be calculated for you.

Print your name and the name of your school on the lines above.

A separate answer sheet for multiple-choice questions in Parts A, B-1, B-2, and D has been provided to you. Follow the instructions from the proctor for completing the student information on your answer sheet.

You are to answer all questions in all parts of this examination. Record your answers for all multiple-choice questions, including those in Parts B-2 and D, on the separate answer sheet. Record your answers for all open-ended questions directly in this examination booklet. All answers in this examination booklet should be written in pen, except for graphs and drawings, which should be done in pencil. You may use scrap paper to work out the answers to the questions, but be sure to record all your answers on the answer sheet or in this examination booklet as directed.



**When you have completed the examination, you must sign the declaration printed on your separate answer sheet, indicating that you had no unlawful knowledge of the questions or answers prior to the examination and that you have neither given nor received assistance in answering any of the questions during the examination. Your answer sheet cannot be accepted if you fail to sign this declaration.**

**Notice ...**

**A four-function or scientific calculator must be available for you to use while taking this examination.**

**DO NOT START THIS EXAMINATION UNTIL THE SIGNAL IS GIVEN.**

## Part A

**Answer all questions in this part.** [30]

*Directions* (1–30): For *each* statement or question, record on the separate answer sheet the *number* of the word or expression that, of those given, best completes the statement or answers the question.

1 The respiratory system of an elephant functions in a similar way to which organelle in a single-celled organism?

- (1) cell membrane
- (2) nucleus
- (3) vacuole
- (4) chloroplast

2 The carrying capacity of an environment may be *decreased* by

- (1) maintaining biodiversity
- (2) replacing lost minerals
- (3) removing dead organisms
- (4) preventing deforestation

**GO RIGHT ON TO THE NEXT PAGE →**

3 The offspring of a species of bird known as the European roller possess an effective defense mechanism. When they sense a threat by predators, the young birds vomit and cover themselves with a foul-smelling liquid.



European roller

Source: <http://www.hbw.com/species/>

Which two systems work together to alert the young birds of danger and help produce the vomit?

- (1) respiratory and excretory
- (2) circulatory and immune
- (3) nervous and digestive
- (4) reproductive and muscular

4 A *decrease* in the biodiversity of an ecosystem usually leads to

- (1) an increase in predator and prey populations
- (2) the elimination of material cycling
- (3) a decrease in stability
- (4) an increase in dynamic equilibrium

5 Down syndrome occurs when an individual has an extra copy of chromosome 21. This additional genetic material alters development and results in Down syndrome. This genetic abnormality is an example of

- (1) a mutation
- (2) fertilization
- (3) a substitution
- (4) differentiation

6 Most of the reactions by which energy from carbohydrates is released for use by the cell take place within the

- (1) mitochondria
- (2) nuclei
- (3) ribosomes
- (4) vacuoles

7 Which human activity best represents a method for recycling nutrients?

- (1) mixing lawn clippings with vegetable waste to produce compost used to fertilize gardens
- (2) raking and bagging lawn clippings in plastic bags for disposal in landfills
- (3) collecting lawn and garden wastes for burning
- (4) clearing a forested area to provide open land for cattle

8 Rabbit populations vary in size over time. An increase in which factor would likely prevent the rabbit population from steadily increasing?

- (1) food
- (2) mates
- (3) predators
- (4) prey

9 The diagrams below represent two reproductive processes used by different organisms.

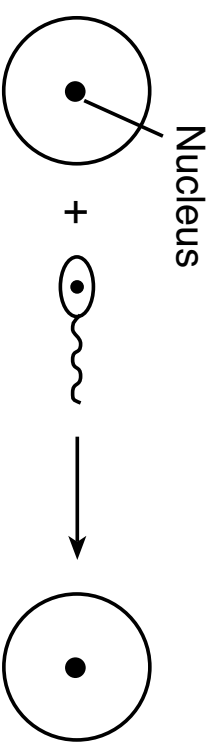

Process A

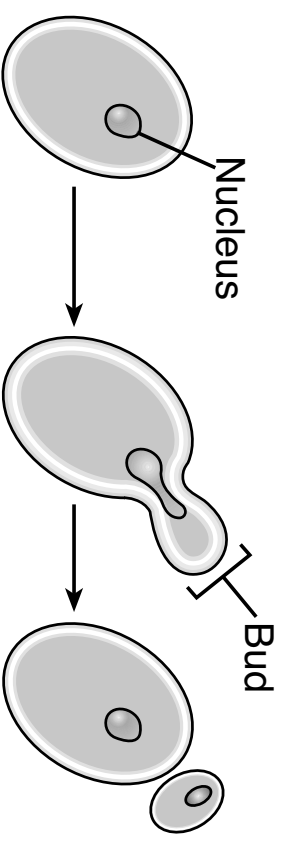

Process B

(Not drawn to scale)

When compared to organisms that utilize process A, organisms that utilize process B would most likely produce offspring with

- (1) a greater variety of genetic combinations
- (2) fewer genetic differences
- (3) more genetic combinations
- (4) more DNA within each nucleus

10 A weightlifter has spent years building his muscular strength. His newborn daughter has normal strength for a baby. Which statement best explains this situation?

- (1) A daughter inherits most of her traits from her mother. The daughter's muscles are unlikely to resemble her father's.
- (2) The weightlifter's wife probably did not lift weights. Both parents must have this trait before the baby can inherit it.
- (3) Babies do not have strong muscles. The daughter's muscles will be unusually strong in a few more months.
- (4) The weightlifter's highly developed muscles resulted from exercise. A characteristic such as this will not be inherited.

11 When it is disturbed, the bombardier beetle is able to produce and release a hot spray of irritating chemicals from the end of its body, as shown in the photo below. As a result, most animals that have experienced this defense avoid the beetles in the future.



Source: <http://www.bbc.com/news/uk-england-leeds-11959381>

The beetle's defense mechanism has developed as a result of

- (1) the need for an effective protection against its enemies
- (2) competition with its predators
- (3) natural selection over many generations
- (4) ecological succession over hundreds of years

12 Rejection of a newly transplanted organ is caused by

- (1) the immune system reacting to the presence of the organ
- (2) antibiotics that stimulate the immune system to attack the organ
- (3) inheritance of genetic disorders from infected individuals
- (4) development of cancerous cells in the organ

13 One of the largest and oldest organisms on Earth is located in Fishlake National Forest in Utah. Pando is an 80,000-year-old grove of aspen trees that covers 100 acres. Although it looks like a forest, DNA analysis of several of the “trees” has confirmed it is really just one huge organism. Therefore, the “trees” must have been reproduced

- (1) sexually and have genetic variability
- (2) asexually and have genetic variability
- (3) sexually and are genetically identical
- (4) asexually and are genetically identical

14 A female giraffe has 62 chromosomes in each of her skin cells.

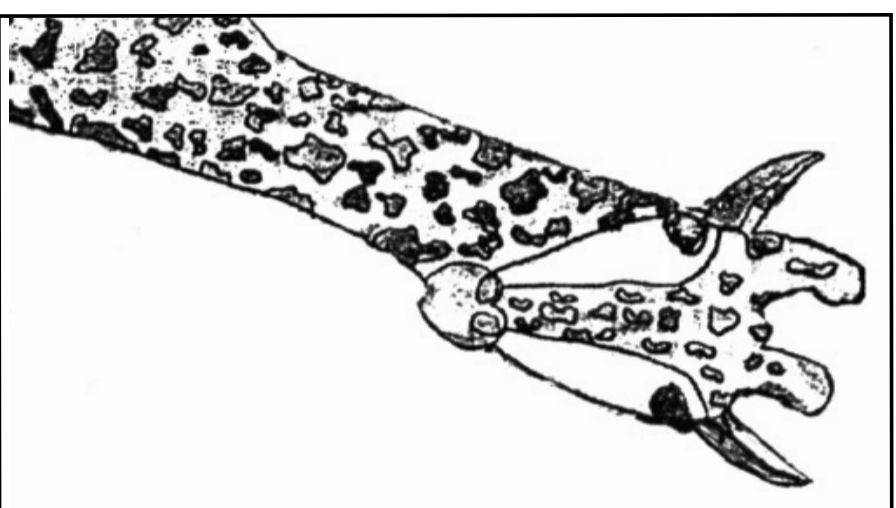

How many chromosomes will be in the skin cells of her offspring?

- (1) 124
- (2) 62
- (3) 31
- (4) 30



- 15 Many female mammals, such as dogs, give birth to litters consisting of multiple offspring. All of the characteristics described below are reproductive adaptations that female dogs have for giving birth and caring for several offspring at once, *except*
- (1) a specialized structure for internal development of several young
  - (2) several pairs of mammary glands that provide milk for their pups
  - (3) ovaries capable of releasing many gametes at one time for fertilization
  - (4) a pancreas that produces excess insulin to trigger the release of eggs
- 16 As blood glucose levels increase, hormones are released to return glucose levels to normal. This is an example of
- (1) a nervous system disorder
  - (2) the synthesis of antibodies
  - (3) a stimulus and a response
  - (4) an antigen and antibody reaction

- 17 BRCA genes are human genes that normally work to help shut down cancer cells before they can harm the body. Scientists have learned that individuals inheriting a damaged form of a BRCA gene are at greater risk of developing breast or ovarian cancer. This discovery is an important first step in
- (1) preventing the uncontrolled meiotic division of cells in humans
  - (2) identifying individuals at risk and recommending preventive treatment
  - (3) being able to detect all the genes that regulate meiosis
  - (4) helping to eliminate all BRCA genes

18 In humans, embryonic development during the first two months is more sensitive to environmental factors than during the remaining months. The best explanation for this statement is that

- (1) during the first two months, organs are being formed and any unusual change during cell division can interfere with normal development
- (2) the genes that control development function only during the first two months of development
- (3) no changes occur in a developing fetus after the second month
- (4) organ development is not affected by environmental factors after the second month

19 Gene editing can be used to swap out an unwanted gene for a desirable one from the same species. Which statement best explains why the desired gene will be found in all cells that come from the genetically edited cell?

- (1) The original cell will reproduce by meiosis and a mutation will occur.
- (2) The altered DNA in the edited cell will be replicated and passed on to each new cell during mitosis.
- (3) DNA replication in body cells will result in sperm and egg cells with the edited gene.
- (4) The desired gene will be inserted into each new cell by using restriction enzymes.

20 Which sequence of events best represents ecological succession?

- (1) A squirrel eats acorns, and a hawk eats the squirrel.
- (2) Grass grows on a sand dune and is slowly replaced by shrubs.
- (3) After many years of planting corn in the same field, minerals present in the soil are used up.
- (4) The decomposition of plant material releases nutrients, and other plants use these nutrients.

21 Which human activity has the potential to greatly affect the equilibrium of an ecosystem?

- (1) cutting down a few small evergreen trees and using them to make holiday decorations
- (2) mowing the playing fields in a city park
- (3) washing a car with a detergent-based cleaner
- (4) emptying an aquarium containing many nonnative fish of several species into a local lake

22 Which statement describes a failure of homeostasis in humans?

- (1) When activity in an individual increases, the body temperature rises and the individual sweats.
- (2) As the concentration of carbon dioxide increases in the human body, the lungs begin to expel more carbon dioxide.
- (3) A viral infection leads to a decrease in the number of white blood cells being produced in the body.
- (4) After an individual gets a cut, certain chemical changes begin the healing process.

23 Some environmental engineering companies have recently designed “manufactured wetlands” to serve as natural sewage treatment plants. Utilizing the ability of wetland organisms to reduce human wastes makes use of naturally occurring

- (1) nutrient cycles
- (2) energy cycles
- (3) limiting factors
- (4) finite resources

24 A hummingbird may need to consume up to 50% of its body weight in sugar each day, just to meet its energy needs. Some of this energy is stored and some is used for metabolic activities, but much of the energy is

- (1) converted into amino acids needed for the production of starch
- (2) released as heat energy back into the hummingbird’s environment
- (3) changed into radiant energy, which can be used by plants for photosynthesis
- (4) used to synthesize inorganic compounds necessary for cellular respiration

25 Sustainable development occurs when people use their resources without depleting them. Which human activity is the best example of sustainable development?

- (1) draining a wetland to build houses
- (2) loggers planting a tree for each one cut down
- (3) using nets to quickly capture large numbers of fish
- (4) building coal-burning power plants to provide electricity

26 Ringworm is a skin infection common among school-aged children. Although the name suggests that a worm causes the disease, it is actually caused by a fungus that lives and feeds on the dead outer layer of the skin. The relationship between ringworm and humans can be described as

- (1) predator/prey
- (2) predator/host
- (3) parasite/prey
- (4) parasite/host

27 Genetically identical yarrow plants were grown at different altitudes. Even though their genetic makeup was identical, the plants grew to different heights. One likely explanation for the different heights of the plants at each altitude is that

- (1) gene expression was influenced by the environment
- (2) genes mutated when the plants were grown at higher elevations
- (3) chromosomes increased in number with elevation change
- (4) the sequence of DNA bases was altered at different altitudes

28 Which biological process is represented in the diagram below?

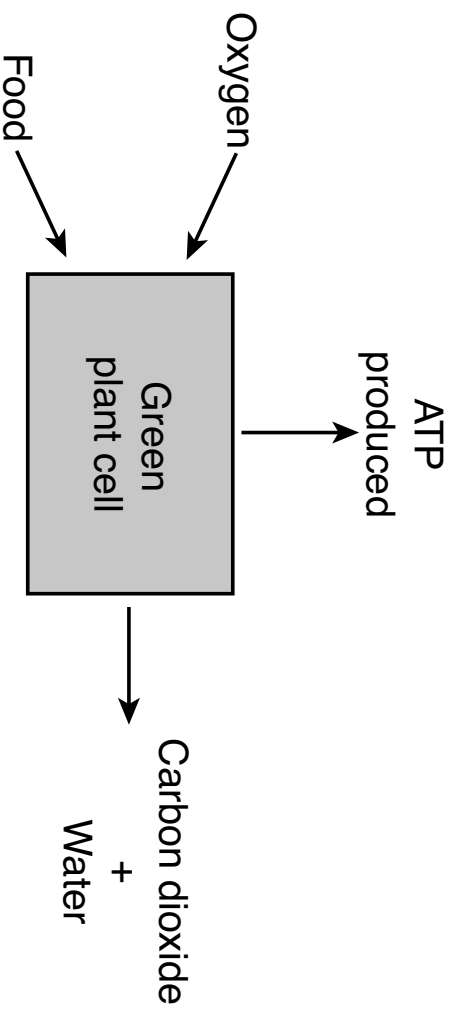

- (1) photosynthesis
- (2) respiration
- (3) digestion
- (4) replication

29 The diagram below shows specialized plant cells that control openings called stomates.

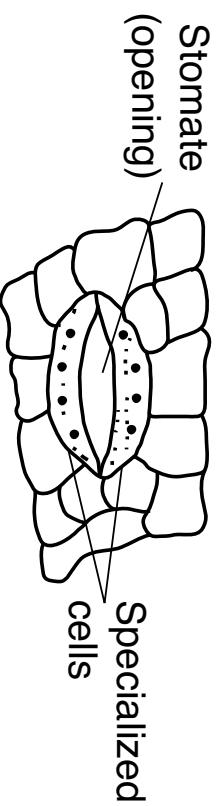

- The proper function of these cells is vital to the survival of the plant because they regulate the
- (1) rate of glucose use by root cells
  - (2) absorption of sunlight by leaf cells
  - (3) products of photosynthesis in the stem
  - (4) exchange of gases in leaves

30 Substance X directly supplies energy for various life functions, as shown in the diagram below.

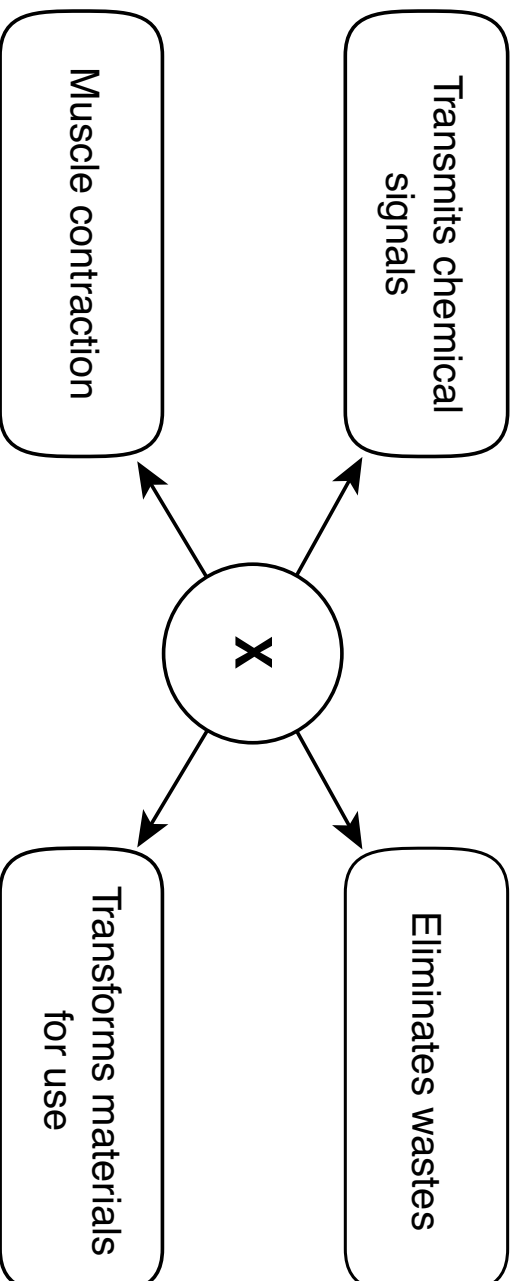

Which substance is represented by X in the diagram?

- (1) ATP
- (2) DNA
- (3) starch
- (4) glucose

---

**GO RIGHT ON TO THE NEXT PAGE →**

## Part B-1

**Answer all questions in this part.** [13]

*Directions* (31–43): For *each* statement or question, record on the separate answer sheet the *number* of the word or expression that, of those given, best completes the statement or answers the question.

Base your answers to questions 31 through 33 on the information below and on your knowledge of biology.

A student set up an experiment to test the effect of the number of seedlings planted in one pot on the rate of growth. All conditions in the experiment were the same, except for the number of plants in each pot. The results are shown in the graph below.

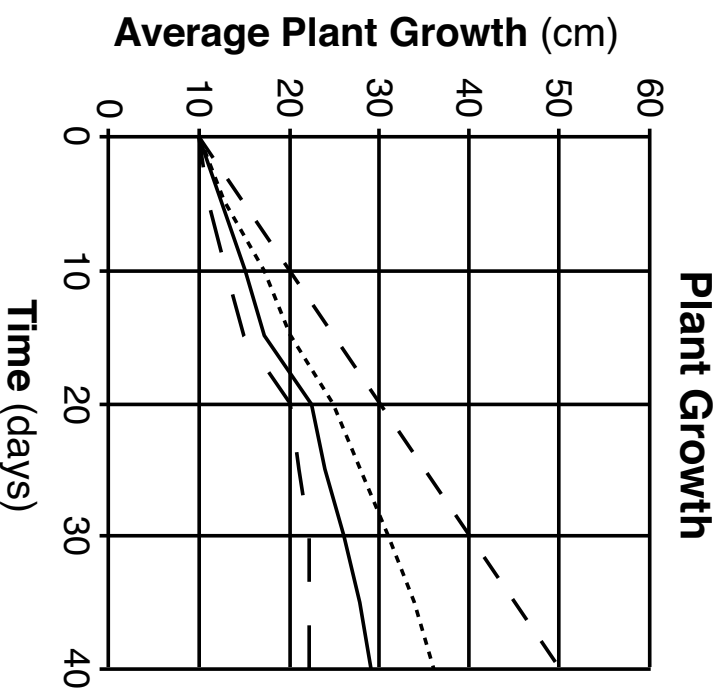

<b>Key</b>	
---	Plant growth (cm) - 5 plants per pot
.....	Plant growth (cm) - 10 plants per pot
—	Plant growth (cm) - 15 plants per pot
—	Plant growth (cm) - 20 plants per pot

Source: Adapted from <http://science.halleyhosting.com/sci/soph/scimethod/q/q1/q9.htm#method>



- 31 The most likely reason for the differences in plant growth in the different pots was
- (1) cyclic changes in the plants' ecosystems
  - (2) ecological succession over time
  - (3) the amount of light available for each setup
  - (4) competition for resources in each setup

- 32 According to the graph, which statement is true concerning the growth of the plants?
- (1) The plants in the pot with only 5 plants grew to be an average of 40 cm tall in 30 days.
  - (2) The plants in the pot with only 10 plants grew to be an average of 30 cm tall in 20 days.
  - (3) The plants in the pot with 15 plants grew an average of 20 cm taller after a period of 10 days.
  - (4) The plants in the pot with 20 plants grew an average of 20 cm taller after a period of 40 days.

- 33 The dependent variable for this experiment was
- (1) the number of plants per pot
  - (2) time in days
  - (3) average plant growth
  - (4) the amount of water per pot
-

Base your answers to questions 34 and 35 on the diagram below and on your knowledge of biology. The diagram represents interactions between organisms in an ecosystem.

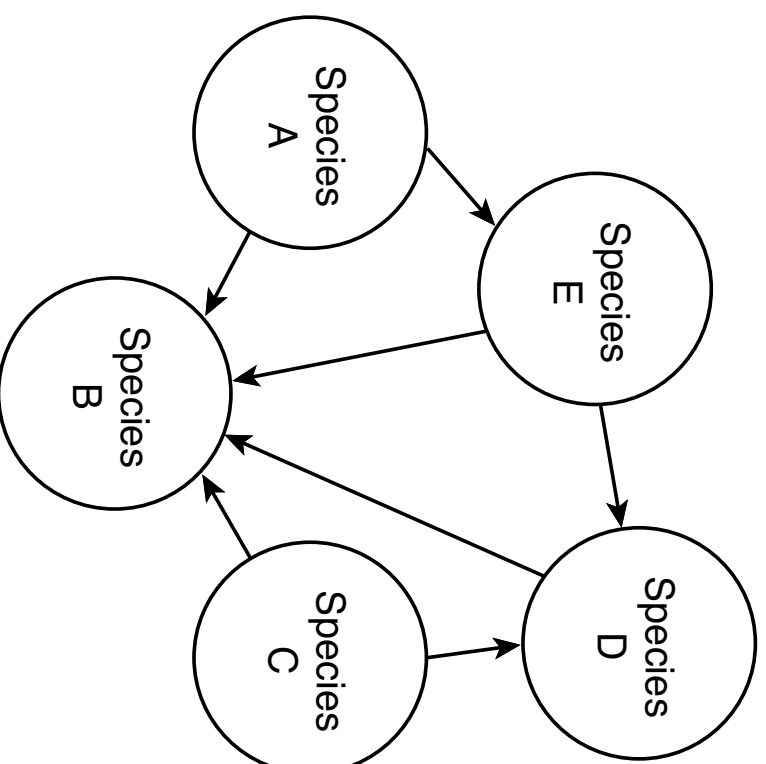

34 Which statement correctly identifies a possible role of *one* organism in this ecosystem?

- (1) Species *A* may carry out autotrophic nutrition.
- (2) Species *B* may be a producer that synthesizes nutrients.
- (3) Species *C* carries out heterotrophic nutrition.
- (4) Species *D* can recycle energy from the Sun.

35 Which statement correctly describes an interaction that contributes to the stability of this ecosystem?

- (1) Species *E* is not affected by the activity of species *A*.
  - (2) Species *B* returns compounds to the environment that may later be used by species *C*.
  - (3) Species *C* recycles nutrients from species *B* and *D* to obtain energy.
  - (4) Species *D* is directly dependent on the autotrophic activity of species *B*.
-

Base your answers to questions 36 and 37 on the information below and on your knowledge of biology.

The Venus flytrap is a plant that uses specialized leaves in order to capture and digest small insects.



Source: <https://www.britannica.com/plant/Venus-flytrap>

36 Although the Venus flytrap uses its prey to obtain certain molecules that it needs, it is still classified as a producer because it

- (1) uses its prey to produce food
- (2) consumes the prey to produce energy
- (3) synthesizes energy by using oxygen and releasing carbon dioxide
- (4) synthesizes glucose by using carbon dioxide and water

37 Enzymes secreted by cells in the leaves of the Venus flytrap can digest

- (1) proteins into amino acids
  - (2) sugars into starches
  - (3) amino acids into fats
  - (4) proteins into sugars
-

Base your answers to questions 38 and 39 on the information below and on your knowledge of biology.

### **Ulcers: Mystery Solved**

Stomach ulcers are painful sores that develop in the stomach. Doctors once thought that ulcers were caused by stress. In the 1980s, a pair of physicians, Barry J. Marshall and J. Robin Warren, questioned the cause of ulcers. They found the bacterium *Helicobacter pylori* in the ulcer tissue of their patients. Even though they repeatedly presented their findings to colleagues, they were ignored until Marshall performed an astonishing experiment: He drank broth containing the bacteria and made himself sick with an ulcer! He then cured himself by taking an antibiotic.

The results were published in 1985, but it took another 10 years for doctors to regularly use antibiotics to treat ulcers. Marshall and Warren received a Nobel Prize in 2005 for this discovery.

- 38 Which choice represents a possible hypothesis for Marshall's experiment?
- (1) Does *Helicobacter pylori* cause stomach ulcers in people?
  - (2) If a person takes an antibody, then they will not develop an ulcer.
  - (3) Does exposure to infectious bacterial cells make people sick?
  - (4) If a patient is infected by *Helicobacter pylori*, then they will get an ulcer.
- 39 The work of Marshall and Warren shows that
- (1) hypotheses made by physicians are always correct
  - (2) scientific explanations are revised based on new evidence
  - (3) peer review always leads to the immediate acceptance of results
  - (4) conclusions must always be consistent with those made by other scientists
-

40 The structural formulas shown below represent parts of two different complex carbohydrate molecules composed of glucose subunits. Molecules 1 and 2 differ in their overall structure.

**Molecule 1**

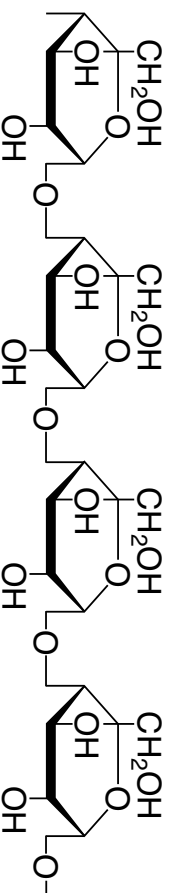

**Molecule 2**

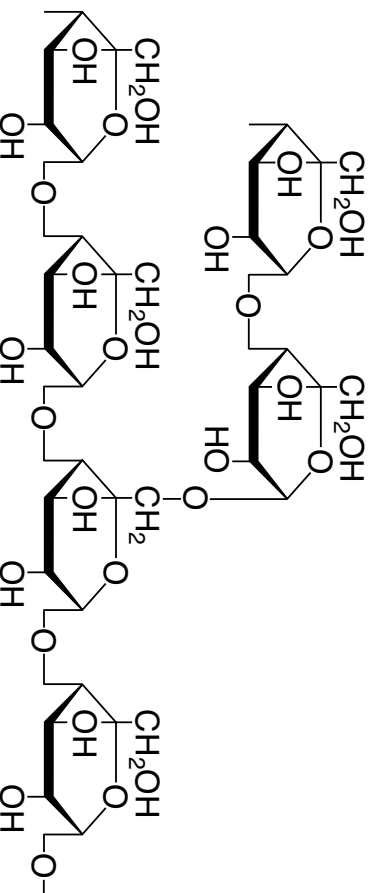

Source: Adapted from <http://www.rsc.org/Education/Teachers/Resources/cfb/carbohydrates.htm>

Due to the differences in structure, each of these molecules most likely

- (1) is composed of different molecular bases
- (2) forms a different protein
- (3) contains different elements
- (4) performs a different function

41 To capture their prey, spiders have fangs, which pierce the body wall of insects and inject venom. Spider venoms usually contain specific proteins that attack the cell membranes of the prey. The membranes and most of the contents of the insect's body turn into a liquid that the spider then ingests for food.

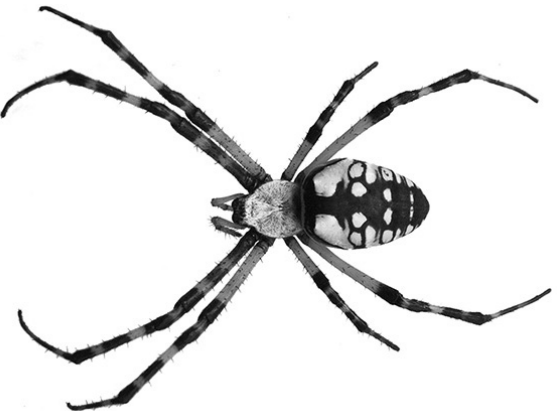

Source: <https://www.pest-control.com/>

These specific venom proteins are most likely

- (1) ATP molecules
- (2) DNA molecules

- (3) biological catalyzes
- (4) regulatory hormones



42 Lymphatic capillaries are found throughout the body. Both the lymphatic and circulatory systems transport substances between the bloodstream and body tissues. These two systems are also involved in fighting infections.

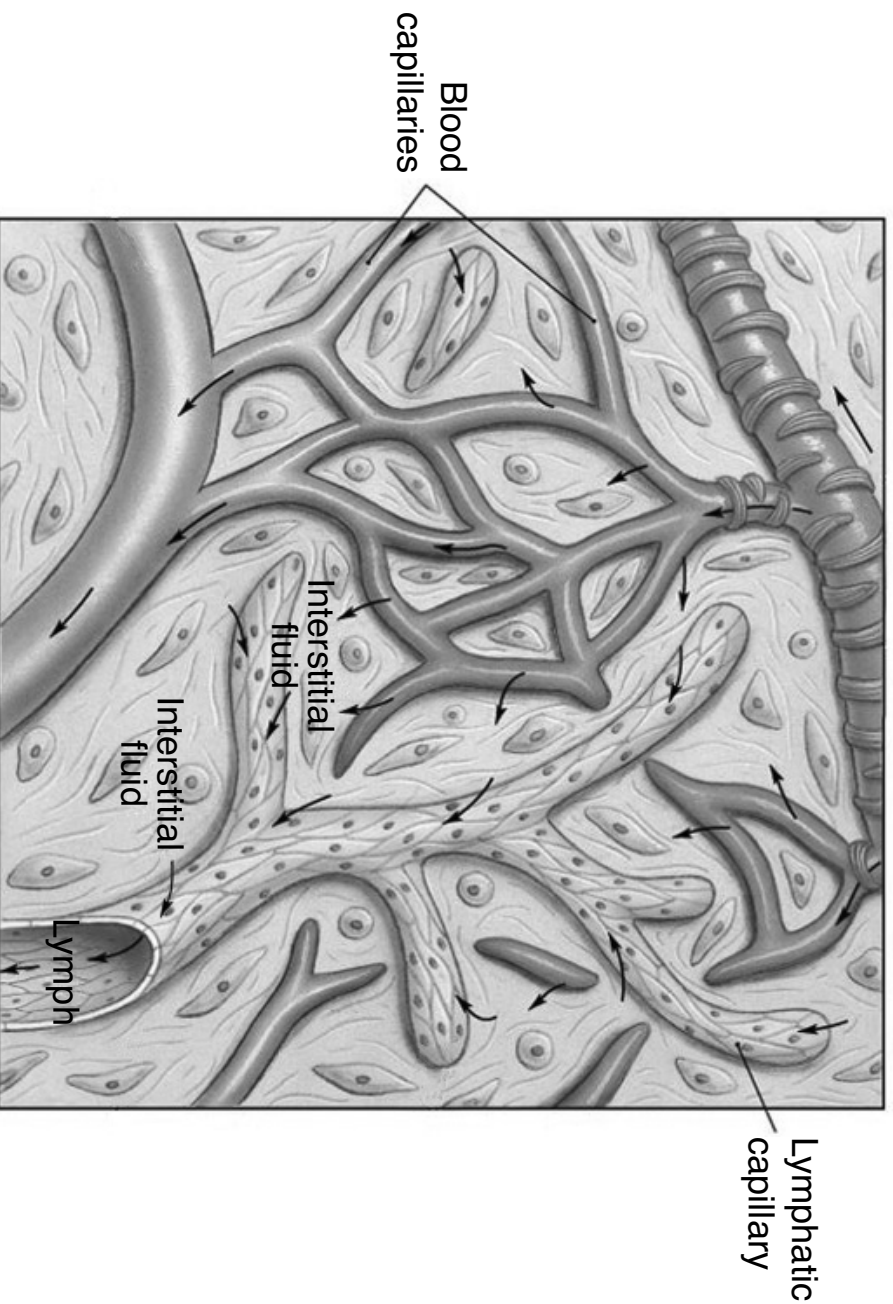

Source: Adapted from <http://droualb.faculty.mjc.edu>

The arrows shown in the diagram that go from the blood capillaries to the interstitial fluid most likely represent the

- (1) release of red blood cells, so that they can diffuse into body cells and fight bacteria
- (2) movement of materials from the circulatory system that will eventually enter lymphatic capillaries
- (3) transport of digestive enzymes from the blood to help with the digestion of glucose in muscle cells
- (4) transport of glucose molecules from the blood to be used by cells to attack proteins and fats

43 The graph below shows how the introduction of the opossum shrimp, as a food source for salmon, affected a lake ecosystem in Montana.

### Changes in Montana Lake Species

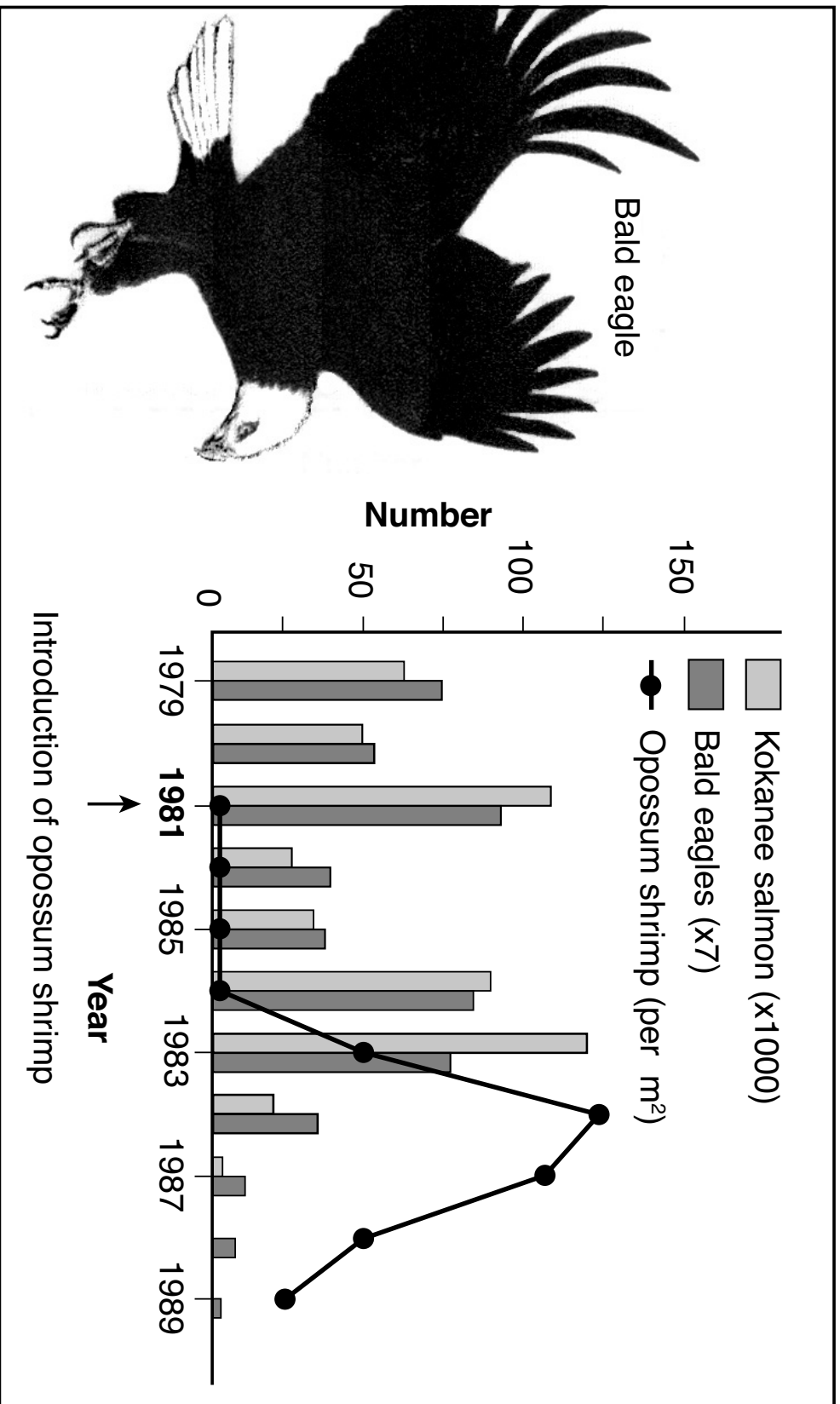

Source: *Biology*, 9th Ed. Sylvia Mader, McGraw-Hill, Boston, 2007, p.929

Based on the data in this graph, one likely conclusion that can be made is that over approximately ten years

- (1) the lake ecosystem stabilized after the introduction of the new species
- (2) competition between organisms was reduced as more producers were introduced into the lake
- (3) more predators moved into the lake ecosystem once the opossum shrimp were added
- (4) the introduction of the opossum shrimp into the lake ecosystem disrupted the food webs that were present

**GO RIGHT ON TO THE NEXT PAGE →**

## Part B–2

**Answer all questions in this part.** [12]

*Directions (44–55):* For those questions that are multiple choice, record on the separate answer sheet the *number* of the choice that, of those given, best completes each statement or answers each question. For all other questions in this part, follow the directions given and record your answers in the spaces provided in this examination booklet.

Base your answers to questions 44 through 47 on the information below and data table on page 30 and on your knowledge of biology.

Peregrine falcons are an endangered species in New York State. This crow-sized predator feeds primarily on birds. Starting in the 1940s, exposure to the pesticide DDT in their prey caused declines in the peregrine falcon population. These pesticides caused eggshell thinning, which drastically lowered breeding success. By the early 1960s, peregrine falcons no longer nested in New York State. After the United States banned DDT in 1972, efforts were made to reintroduce peregrine falcons into the Northeast. Since the 1980s, the peregrine falcons are once again breeding in many areas of New York State.

## Questions 44-47 continued



Source: <http://www.dailymail.co.uk/news/article-1018309/Peregrine-falcons-return-breed-time-200-years.html>

**GO RIGHT ON TO THE NEXT PAGE →**

The table below shows the number of peregrine falcon offspring produced in New York State over a 20-year period.

**Number of Peregrine Falcon Offspring  
Produced in New York State From 1992 to 2012**

Year	Number of Offspring Produced
1992	30
1996	48
2000	75
2004	79
2008	129
2012	148

*Directions (44–45):* Using the information in the data table, construct a line graph on the grid on the next page, following the directions below and on the next page.

44 Mark an appropriate scale, without any breaks in the data, on each labeled axis. [1]

**GO RIGHT ON TO THE NEXT PAGE →**

45 Plot the data on the grid. Connect the points and surround each point with a small circle. [1]

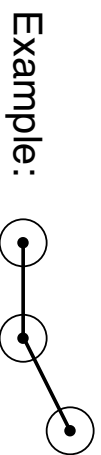

**Number of Peregrine Falcon Offspring Produced  
in New York State from 1992-2012**

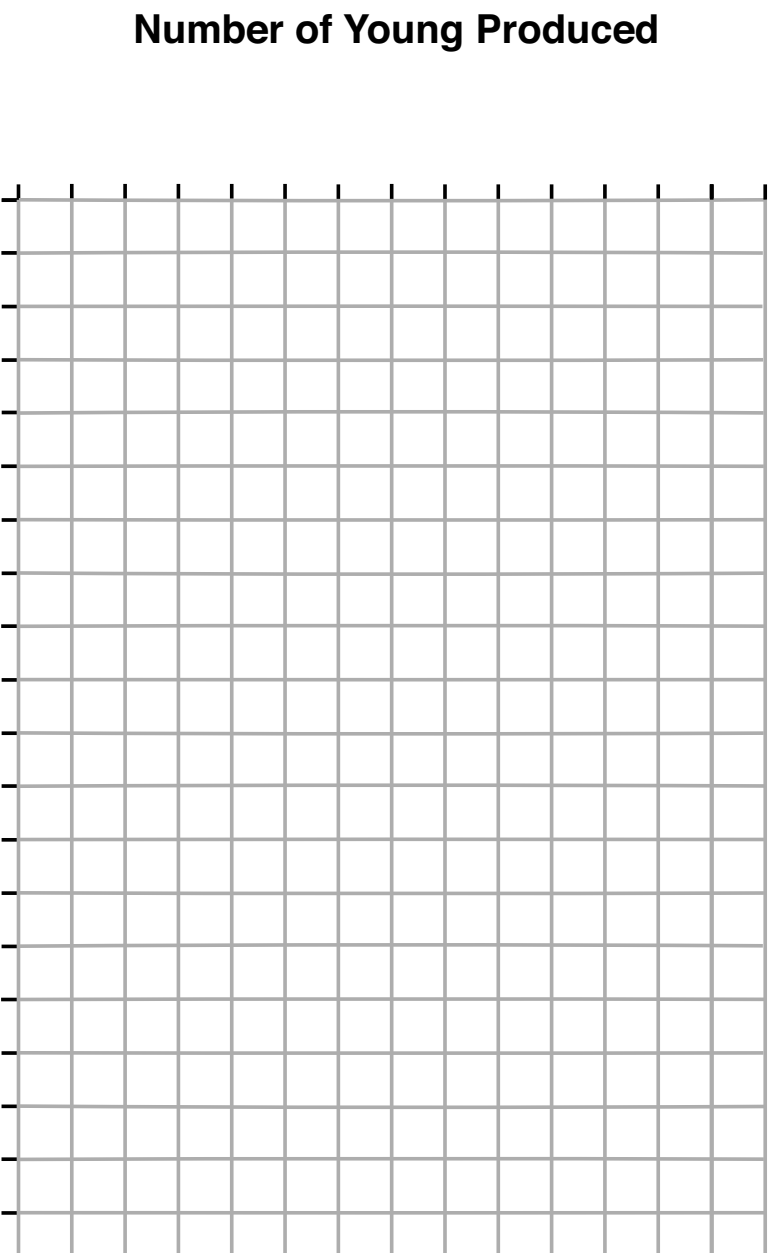

**GO RIGHT ON TO THE NEXT PAGE →**

46 Identify a body system in the falcon that was directly affected by DDT and led to the loss of nesting peregrine falcons from New York State in the early 1960s. Support your answer. [1]

Body system: \_\_\_\_\_

Support: \_\_\_\_\_

**Note: The answer to question 47 should be recorded on your separate answer sheet.**

47 Which conclusion is best supported by the information presented in the graph?

- (1) The greatest decrease was during the time period of 1992 and 1996.
- (2) The greatest increase was during the time period of 2004 and 2008.
- (3) There has been a steady decline since the banning of DDT in 1972.
- (4) The population reached carrying capacity in 2004.

\_\_\_\_\_



Base your answers to questions 48 and 49 on the information below and on your knowledge of biology.

A scientist added an antibiotic to a Petri dish containing bacterial colonies. A day later, the scientist noticed that many colonies had died, but a few remained. The scientist continued to observe the dish and noted that, eventually, the remaining colonies of bacteria increased in size.

48 Explain why the results of this study may indicate *one disadvantage* of using antibiotics to fight infections. [1]

---

---

**Note: The answer to question 49 should be recorded on your separate answer sheet.**

49 The survival of some bacterial colonies was most likely due to

- (1) the bacterial cells changing so that they could live
  - (2) a resistance to the antibiotic
  - (3) meiotic cell division in the bacteria
  - (4) a DNA change caused by the antibiotic
-

Base your answers to questions 50 and 51 on the information below and on your knowledge of biology.

The diagrams below provide information about two separate species of tree frogs found in the United States. The shaded areas represent the habitats of each of the two species.

### **Tree Frogs of the United States**

**Gray Tree Frogs**



**Green Tree Frogs**

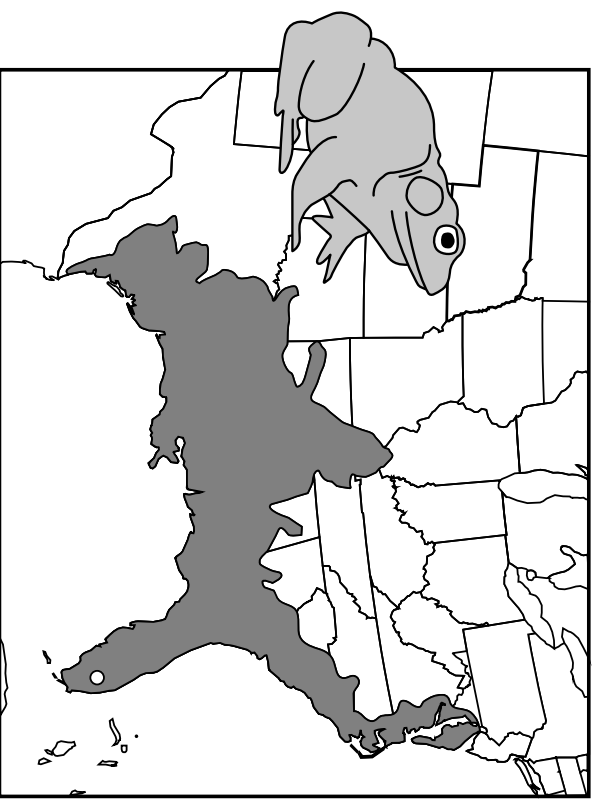

Source: Adapted from Roger Conant and Joseph T Collins. 1998. *A Field Guide to Reptiles & Amphibians of Eastern & Central North America* (Peterson Field Guide Series).

**Note: The answer to question 50 should be recorded on your separate answer sheet.**

50 One likely reason that the gray tree frog occupies a larger environmental area than the green tree frog is that the gray tree frog species

- (1) eats only prey found in central areas in the United States
- (2) is adapted to live in any environment in the United States
- (3) has adaptations that enable survival in a wider variety of habitats
- (4) outcompetes the green tree frogs in Florida and any state where they both live

51 Identify a biological process that led to the presence of 90 different species of frogs throughout the United States. Support your answer. [1]

Biological process: \_\_\_\_\_

---

---

---

**GO RIGHT ON TO THE NEXT PAGE →**

Base your answer to question 52 on the information below and on your knowledge of biology. The diagram below represents the human female reproductive system.

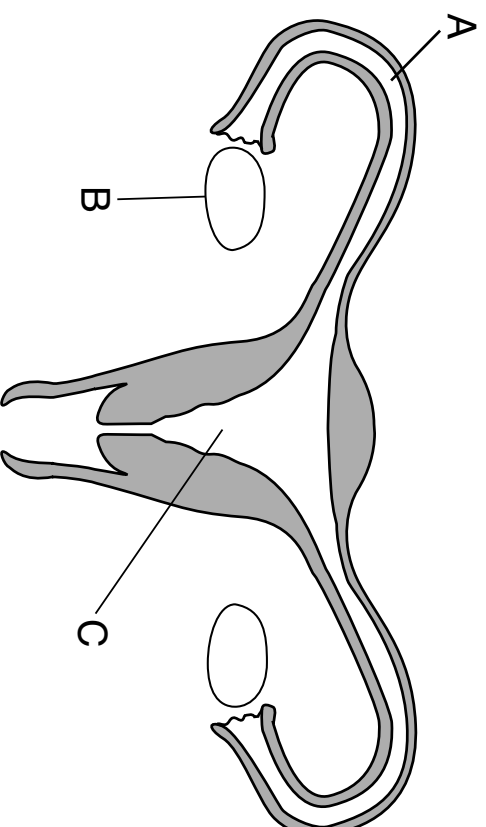

52 Select *one* of the lettered parts from the diagram. Circle the letter of the part that you selected, and identify the part. State how a malfunction in the structure that you identified could interfere with an individual's ability to reproduce. [1]

Part selected (circle one)      A      B      C

Identification: \_\_\_\_\_

Explanation: \_\_\_\_\_

---

---

---

53 The diagram below represents a cell nucleus. Complete the diagram so that it shows the arrangement of the genetic material in the two new cells that are produced by mitosis. [1]

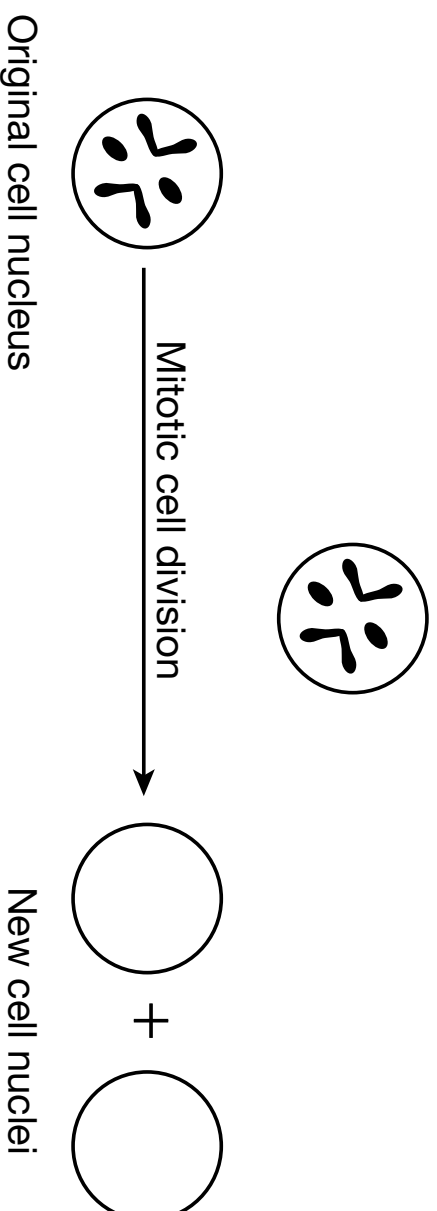

54 Sometimes a hypothesis is not supported. Yet, scientists consider the findings valuable. State *one* reason scientists would value an experiment that does *not* support the initial hypothesis. [1]

---

---

55 The sequence below represents different organizational levels within the human body, from the simplest to more complex. Complete the sequence by correctly filling in the missing levels. [1]

organelles → \_\_\_\_\_ → tissues → \_\_\_\_\_ → organ systems → organism

---

## Part C

### Answer all questions in this part. [17]

*Directions (56–72):* Record your answers in the spaces provided in this examination booklet.

Base your answers to questions 56 through 58 on the passage below and on your knowledge of biology.

#### **Indian Ocean Ecosystem in Danger**

The Indian Ocean is under increasing environmental pressures. Until recently, this ocean was considered to have the least ecologically disrupted coastline. However, as the surface water temperatures have increased, there has been a reduction in the phytoplankton population (microscopic producers). This reduction in phytoplankton has been linked to a decline in some fish populations.

Also affecting the fish populations is the urbanization of coastal areas. As the human population grows in this area, more of the coastline region is being developed. In addition, the mining of natural resources has led to oil spills, the destruction of mangrove forests, and an increase in the area's acidity level.

Countries along the coast are trying to encourage development while, at the same time, trying to maintain a healthy coastal ecosystem.

56 Explain how a reduction in phytoplankton can lead to a reduction in fish populations in the Indian Ocean. [1]

---

---

57 Describe how *one* specific human activity mentioned in the passage could *negatively* affect the Indian Ocean ecosystem. [1]

Human activity: \_\_\_\_\_

---

---

58 State *one* specific reason why it is important to maintain a healthy ecosystem in the Indian Ocean. [1]

---

---

---

Base your answers to questions 59 through 61 on the photo on the next page and reading passage below, and on your knowledge of biology.

### **Invasive Water Chestnuts Challenge Environmentalists**

Environmental scientists are troubled by the rapid spread of the water chestnut plant. This invasive plant is a freshwater species with leaves that blanket the surface of water. The leaves grow so densely, they stop people from swimming and prevent boats from moving.

Invasive water chestnut leaves prevent 95% of the sunlight from reaching the water below. Local animals and insects cannot eat this plant. New York ecosystems infested by the water chestnut are quickly disrupted. Water chestnut seeds can survive more than ten years under water in the sediments.

The most effective way to kill the water chestnut is to pull out each plant by hand. This can be done in a small pond, but for rivers and lakes that are blocked by huge numbers of water chestnut plants, other methods are needed. Chemical herbicides kill the leaves, but, after several weeks, the water chestnut plants grow back. Large machines have been used to clear these plants and seeds from the water and sediments of ecosystems, but the machines remove many other organisms too.

**GO RIGHT ON TO THE NEXT PAGE →**





Water chestnut  
seed

Source: [estuarylive.pbworks.com](http://estuarylive.pbworks.com)

59 State *one* way that the presence of water chestnut plants affects the other organisms in the freshwater ecosystem. [1]

---

---

60 Some scientists recommend bringing in biological controls, such as introducing a new species of insect to eat the water chestnut leaves and stop its growth. State *one* advantage and *one disadvantage* of using biological controls in this situation. [1]

Advantage: \_\_\_\_\_

\_\_\_\_\_

Disadvantage: \_\_\_\_\_

\_\_\_\_\_

61 Harvesting machines are used to scrape water chestnut plants and seeds from the bottom of lakes and rivers. State *one disadvantage* of this method of controlling water chestnuts. [1]

\_\_\_\_\_

\_\_\_\_\_

\_\_\_\_\_

Base your answers to questions 62 and 63 on the information below and on your knowledge of biology.

**Rising CO<sub>2</sub> [Carbon Dioxide] Levels in Ocean Block Sharks' Ability to Smell Prey**

... Changes in the chemistry of the world's oceans expected by century's end could impact the hunting ability of sharks, which depend heavily on their sense of smell to locate prey, researchers say.

As ocean waters turn increasingly acidic from absorbing atmospheric CO<sub>2</sub> created by human activities, the odor-detecting ability of sharks to locate prey could diminish, they say. ...

Source: Jim Algar, *Tech Times*, 9/9/14

62 Identify *one* human activity and describe how it contributes to increasing levels of carbon dioxide in the environment. [1]

Human activity: \_\_\_\_\_

---

---

---

63 Describe how the inability of sharks to detect their prey could affect an ocean ecosystem. [1]

---

---

---

---

Base your answers to questions 64 through 66 on the information and photo below and on your knowledge of biology. The photo shows an adult female weasel.

### **Weasels Are Built for the Hunt**

Weasels are fierce and quick-witted carnivores that must compete for food with larger predators. Their slender, elongated body plan allows them to pursue prey in tight spaces that other carnivores can't enter, a key factor in controlling rodent and rabbit populations. This body plan is important to the success of weasels. Female weasels have evolved to give birth to fetuses that have not fully completed development. The fetuses complete their development externally. In this way, there is no baby bump to limit the mother's access to tight feeding locations.

A high energy level is key to the weasel's success in capturing prey, but it comes at a price. To survive, weasels need to eat a third of their body weight per day. This need can make them unpopular with poultry farmers, because they can enter through the smallest opening and consume large numbers of chickens.



Source: NY Times 6/13/16

64 State how the body plan of the weasel is effective for successfully competing with other organisms. [1]

---

---

65 If the weasels are so successful, explain why they do *not* completely overpopulate the areas where they live. [1]

---

---

66 Indicate whether the weasels' relationship with humans is positive or negative by circling the appropriate term below. Support your answer. [1]

Relationship (circle one):      positive      negative

Support: \_\_\_\_\_

---

---

Base your answers to questions 67 and 68 on the information and diagram below and on your knowledge of biology.

### **HIV Infection**

The human immunodeficiency virus (HIV), which can lead to AIDS, is a type of virus that adds its genetic material to the DNA of the host cell. HIV reproduces within the host cell and exits through a process called budding.

In the process of budding, the newly forming virus merges with the host cell membrane and pinches off, taking with it a section of the host-cell membrane. It then enters into circulation.

### **HIV Budding**

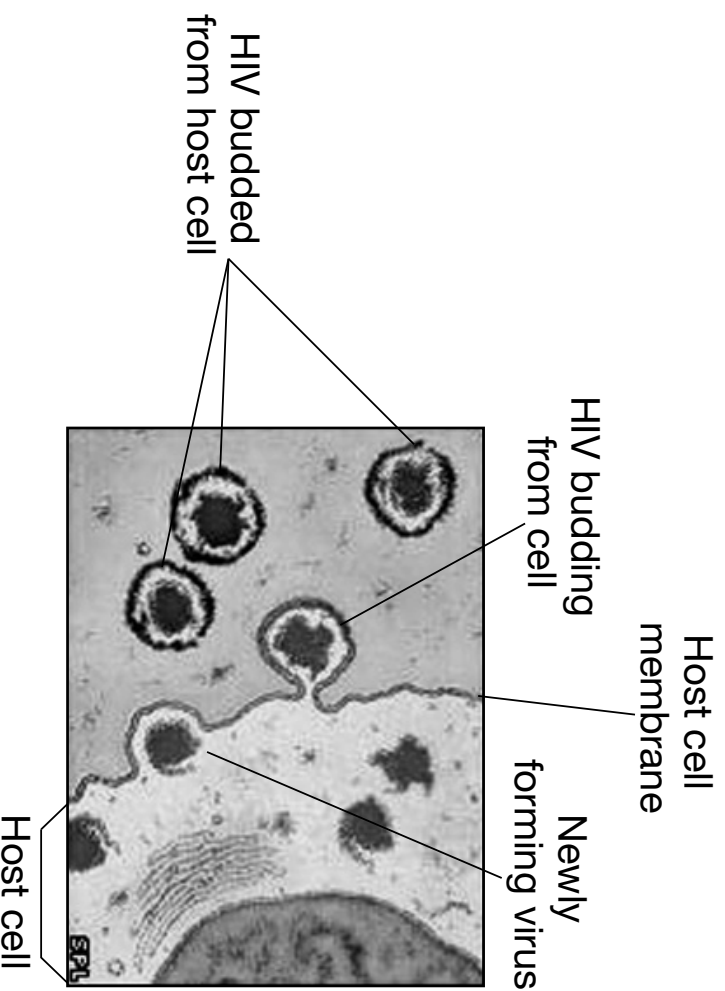

Source: Adapted from <http://news.bbc.co.uk/2/hi/health/5221744.stm>

67 Explain how an outer covering composed of a section of a cell membrane from the host would protect HIV from attack by the host's immune system. [1]

---

---

68 Describe *one* specific way that HIV makes the body unable to deal with other pathogens and cancer. [1]

---

---

Base your answers to questions 69 through 72 on the information below and on your knowledge of biology.

### **Snakes Used to Have Legs and Arms Until These Mutations Happened**

The ancestors of today's slithering snakes once sported full-fledged arms and legs, but genetic mutations caused the reptiles to lose all four of their limbs about 150 million years ago, according to two new studies. ...

Both studies showed that mutations in a stretch of snake DNA called ZRS (the Zone of Polarizing Activity Regulatory Sequence) were responsible for the limb-altering change. But the two research teams used different techniques to arrive at their findings. ...

...According to one study, published online today (Oct. 20, 2016) in the journal *Cell*, the snake's ZRS anomalies [differences] became apparent to researchers after they took several mouse embryos, removed the mice's ZRS DNA, and replaced it with the ZRS section from snakes. ...

...The swap had severe consequences for the mice. Instead of developing regular limbs, the mice barely grew any limbs at all, indicating that ZRS is crucial for the development of limbs, the researchers said. ...

Looking deeper at the snakes' DNA, the researchers found that a deletion of 17 base pairs within the snakes' DNA appeared to be the reason for the loss of limbs.

Source: <http://www.livescience.com/56573-mutation-caused-snakes-to-lose-legs.htm>

69 State *one* possible advantage for a snake to have no limbs instead of four limbs. [1]

---



70 Identify the technique that the scientists used to remove the ZRS DNA from mice and replace it with the ZRS section from snakes. [1]

---

71 Identify the type of mutation responsible for the loss of limbs in snakes. [1]

---

72 Without having DNA samples from snakes 150 million years ago, state how scientists could know that snakes once actually had legs. [1]

---

---

---

## Part D



**Answer all questions in this part.** [13]

*Directions (73–85):* For those questions that are multiple choice, record on the separate answer sheet the *number* of the choice that, of those given, best completes each statement or answers each question. For all other questions in this part, follow the directions given and record your answers in the spaces provided in this examination booklet.

Base your answers to questions 73 and 74 on the information and chart below and on your knowledge of biology.

### Finding Relationships Between Organisms

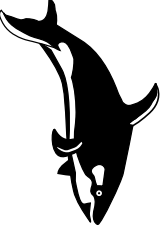
Organisms living in the same environment may have similar body structures, but this does not always indicate a close biological relationship. The chart below provides information about four organisms that live in an Antarctic Ocean ecosystem.

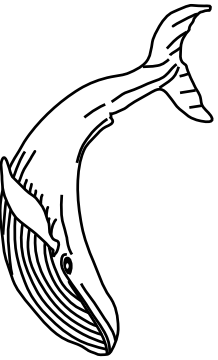
<b>Body Structures of Four Antarctic Marine Organisms</b>				
<b>Organism</b>	<b>Killer whale</b>	<b>Adélie penguin</b>	<b>Leopard seal</b>	<b>Baleen whale</b>
<b>Skin covering</b>	Very little hair	Feathers	Thick hair	Very little hair
<b>Diagram*</b>				
*Pictures are not drawn to scale.				

**Note: The answer to question 73 should be recorded on your separate answer sheet.**

73 Two features that would be the most useful in determining which of these organisms are most closely related are

- (1) presence of hair and similar proteins
- (2) presence of feathers and similar body structures
- (3) habitat and diet
- (4) body size and color

**Note: The answer to question 74 should be recorded on your separate answer sheet.**

74 Which lab procedure can be done to find molecular evidence for relationships between these Antarctic marine organisms?

- (1) Compare slides of cell organelles.
  - (2) Examine fossils and ocean sediments.
  - (3) Set up and perform gel electrophoresis.
  - (4) Use a dichotomous key and test for pH.
-

**Note: The answer to question 75 should be recorded on your separate answer sheet.**

75 As an extension of the lab activity *Making Connections*, a biology teacher asked students to brainstorm variables other than exercise that would affect heart rate. The students hypothesized that eating a lunch high in protein would decrease heart rates. They recorded resting heart rates of 20 students, had them eat high-protein meals, and then recorded their heart rates again. The heart rates of 15 students were lower while the heart rates for 5 students were higher after lunch.

The best explanation for the observation that the heart rates of 5 students were higher after lunch is

- (1) the heart rates of female students are not affected by a high-protein meal
- (2) the students all participated in physical education class immediately before lunch
- (3) the students all had varying physical fitness levels and consumed different amounts of protein
- (4) the students were all the same gender and age

Base your answers to questions 76 and 77 on the passage below and on your knowledge of biology.

A recent study of Darwin's finches in the Galapagos Islands identified the gene, HMGA2, that is involved in beak size. It played a role in which finches feeding on smaller seeds survived a severe drought in 2004-2005. Following the drought, the average size of the medium ground finch beak decreased. This change was traced directly to changes in the frequency of the HMGA2 gene. Previous studies have shown that HMGA2 affects body size in animals, including dogs and horses, and even humans.

**Note: The answer to question 76 should be recorded on your separate answer sheet.**

76 One possible reason that such diverse species could be affected by the HMGA2 gene is that

- (1) they all lived on the Galapagos Islands
- (2) they share a common ancestor
- (3) the drought caused the formation of the gene
- (4) the gene allowed all these species to grow larger

77 State *one* possible reason the medium ground finches with a smaller beak were able to survive during the 2004-2005 drought. Support your answer. [1]

---

---

Base your answer to question 78 on the information and the Universal Genetic Code Chart below and on your knowledge of biology.

### Universal Genetic Code Chart Messenger RNA Codons and the Amino Acids for Which They Code

		SECOND BASE								
		U	C	A	G					
FIRST BASE	U	UUU } UUC } UUA } UUG }	UCU } UCC } UCA } UCG }	UAU } UAC } UAA } UAG }	UGU } UGC } UGA } UGG }	PHE LEU	SER	TYR	CYS STOP TRP	U C A G
	C	CUU } CUC } CUA } CUG }	CCU } CCC } CCA } CCG }	CAU } CAC } CAA } CAG }	CGU } CGC } CGA } CGG }	LEU	PRO	HIS GLN	ARG	U C A G
	A	AUU } AUC } AUA } AUG }	ACU } ACC } ACA } ACG }	AAU } AAC } AAA } AAG }	AGU } AGC } AGA } AGG }	ILE MET or START	THR	ASN LYS	SER ARG	U C A G
	G	GUU } GUC } GUA } GUG }	GCU } GCC } GCA } GCG }	GAU } GAC } GAA } GAG }	GGU } GGC } GGA } GGG }	VAL	ALA	ASP GLU	GLY	U C A G
		THIRD BASE								

Original DNA for protein X:      TAC-GGC-TTA-GCT-CCC-GCG-CTA-AAA

Mutated DNA for protein X:      TAC-GGC-TTG-GCT-CCT-GCG-CTA-AAA

78 Would the mutated DNA strand affect the functioning of protein X? Support your answer. [1]

---

---

---

**GO RIGHT ON TO THE NEXT PAGE →**

Base your answers to questions 79 and 80 on the diagram below and on your knowledge of biology. The diagram represents a hypothetical result of a technique used in a lab.

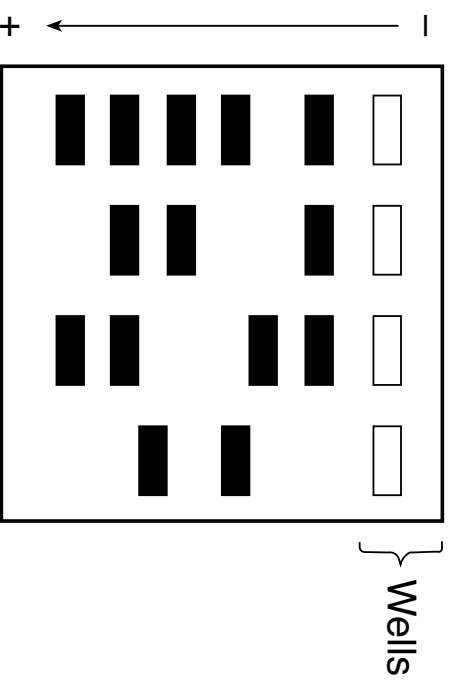

79 State where on the diagram the largest fragments of DNA would be located. [1]

---

80 Identify the factor that caused the fragments to move through the gel rather than remaining in the wells. [1]

---

---



Base your answer to question 81 on the diagram below and on your knowledge of biology.

The diagram represents a sugar cube being dropped into an undisturbed beaker of water at room temperature. One sugar molecule is labeled.

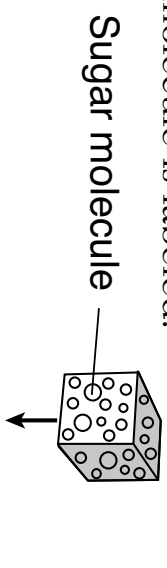

(Not drawn to scale)

**Note: The answer to question 81 should be recorded on your separate answer sheet.**

81 Which diagram below represents the distribution of sugar molecules in the water a day later?

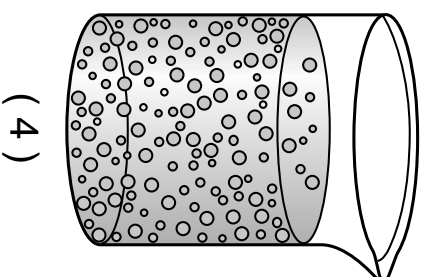
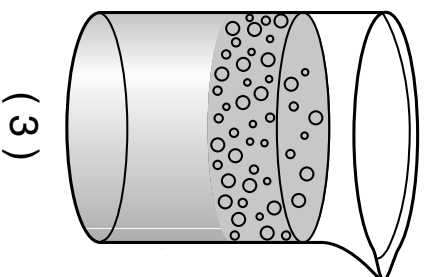
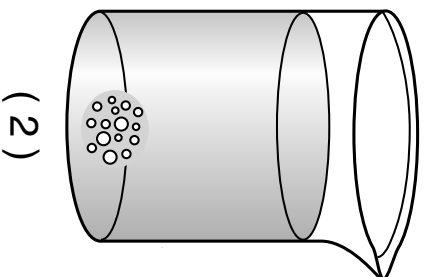
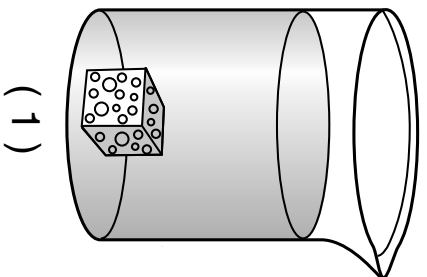

**Note: The answer to question 82 should be recorded on your separate answer sheet.**

82 In an effort to determine how closely related several plant species are, a student performed the laboratory test shown below.

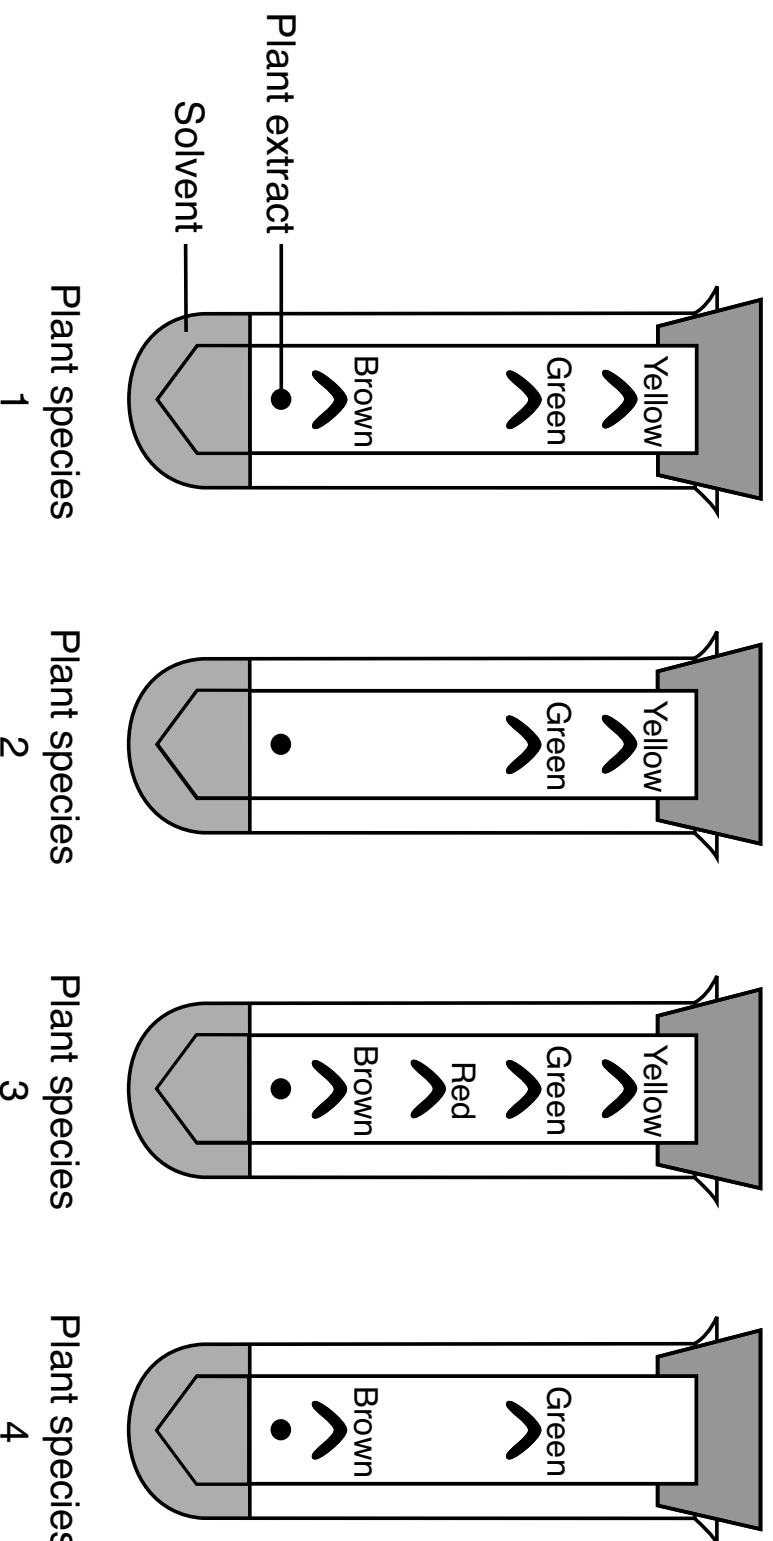

The method used by the student to compare plant extracts from the different species is

- (1) gel electrophoresis
- (2) DNA banding
- (3) a staining technique
- (4) paper chromatography

Base your answer to question 83 on the graph below and on your knowledge of biology. The graph shows the average heart rate data for a group of students before, during, and after exercise.

**Heart Rate Response to Exercise**  
(class average)

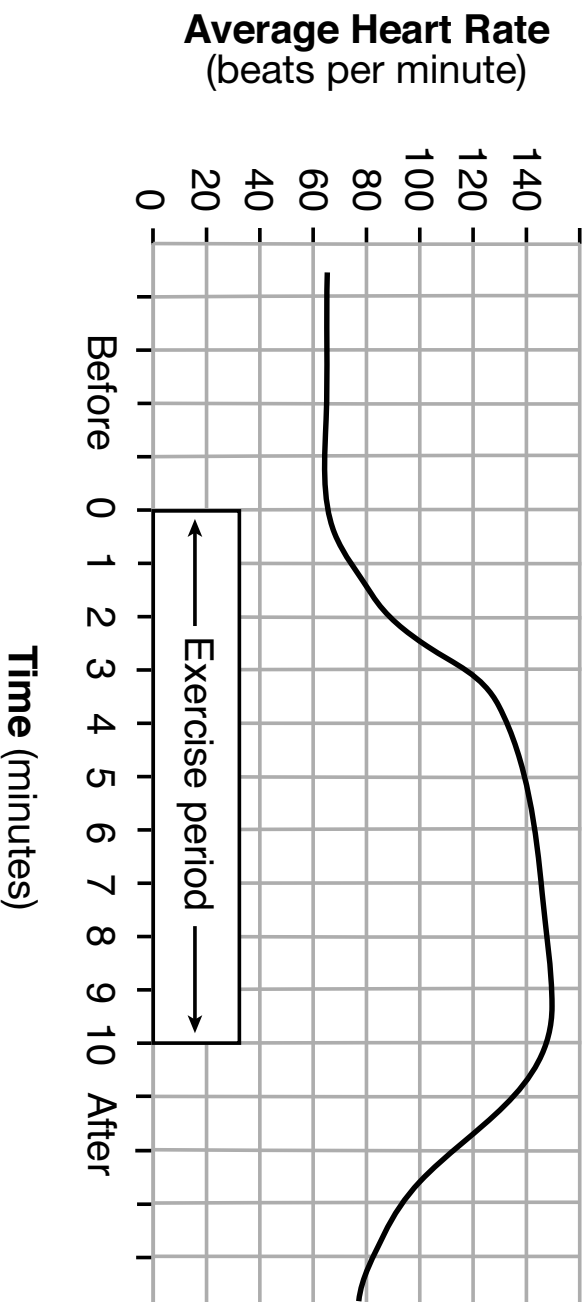

83 State *one* benefit of the increase in average heart rate during exercise. [1]

---

---

---

Base your answers to questions 84 and 85 on the information below and on your knowledge of biology.

### A Clothespin Experiment

A student in a Living Environment class designed an experiment to investigate if the number of times a student squeezes a clothespin varies with the hand used. Her hypothesis was that students could squeeze a clothespin more times in a minute when they used their dominant hand than when they used their nondominant hand.

During her investigation, she first squeezed and released a clothespin as often as possible for 20 seconds with her dominant hand. She recorded the number of squeezes in a chart.

She performed three trials before resting. After that, she repeated the entire procedure with her nondominant hand. Some of the data are shown in the table below.

- 84 Calculate the clothespin-squeezing rates per minute and average for the dominant hand. Record the data in the data table below for all three trials, as well as the average squeezing rate per minute. You should have four numbers recorded. [1]

#### Clothespin Squeezing Activity

<b>Trial</b>	<b>20-Second Clothespin Squeezing (Dominant Hand)</b>	<b>Clothespin-Squeezing Rate Per Minute (Dominant Hand)</b>	<b>20-Second Clothespin Squeezing (Nondominant Hand)</b>	<b>Clothespin-Squeezing Rate Per Minute (Nondominant Hand)</b>
Trial 1	26	_____	18	54
Trial 2	33	_____	28	84
Trial 3	24	_____	29	87
Average		_____		75

85 After performing the experiment, the student's laboratory write-up indicated that the hypothesis was supported. Do you agree with this student? Support your answer. [1]

Agree (circle one):

Yes

No

Support: \_\_\_\_\_

\_\_\_\_\_

\_\_\_\_\_

