

Large-Type Edition

The University of the State of New York

REGENTS HIGH SCHOOL EXAMINATION

LIVING ENVIRONMENT

Wednesday, June 15, 2022 — 1:15 to 4:15 p.m., only

Student Name _____

School Name _____

The possession or use of any communications device is strictly prohibited when taking this examination. If you have or use any communications device, no matter how briefly, your examination will be invalidated and no score will be calculated for you.

Print your name and the name of your school on the lines above.

A separate answer sheet for multiple-choice questions in Parts A, B-1, B-2, and D has been provided to you. Follow the instructions from the proctor for completing the student information on your answer sheet.

You are to answer all questions in all parts of this examination. Record your answers for all multiple-choice questions, including those in Parts B-2 and D, on the separate answer sheet. Record your answers for all open-ended questions directly in this examination booklet. All answers in this examination booklet should be written in pen, except for graphs and drawings, which should be done in pencil. You may use scrap paper to work out the answers to the questions, but be sure to record all your answers on the answer sheet or in this examination booklet as directed.

When you have completed the examination, you must sign the declaration printed on your separate answer sheet, indicating that you had no unlawful knowledge of the questions or answers prior to the examination and that you have neither given nor received assistance in answering any of the questions during the examination. Your answer sheet cannot be accepted if you fail to sign this declaration.

Notice ...

A four-function or scientific calculator must be available for you to use while taking this examination.

DO NOT START THIS EXAMINATION UNTIL THE SIGNAL IS GIVEN.

Part A

Answer all questions in this part. [30]

Directions (1–30): For *each* statement or question, record on the separate answer sheet the *number* of the word or expression that, of those given, best completes the statement or answers the question.

- 1 When the carrying capacity for a species in a habitat is reached, the population of the species levels off. This slowing of the rate of growth is most likely due to
- (1) limited resources
 - (2) renewable energy
 - (3) an increase in decomposers
 - (4) a lack of competition

- 2 On a hot day, dogs sweat through their paw pads and pant, which helps keep them cool. Both the sweating and panting are
- (1) due to a loss of oxygen
 - (2) a failure of cell communication
 - (3) due to a lack of adaptation to the environment
 - (4) a response to a stimulus

- 3 The formation of the many kinds of body cells that make up an embryo begins with
- (1) chemical changes in the cell membranes
 - (2) the clumping together of proteins within the cells
 - (3) specific genes being activated
 - (4) the rapid metabolism of sugar molecules

GO RIGHT ON TO THE NEXT PAGE →

4 Some salmon have been genetically modified to grow bigger at a faster rate than wild salmon. They are kept in fish-farming facilities and are not released into the wild. Which statement regarding genetically modified salmon is most likely true?

- (1) Wild salmon reproduce sexually, while genetically modified salmon reproduce asexually.
- (2) Wild salmon have an altered protein sequence, but genetically modified salmon do not.
- (3) Genetically modified salmon and wild salmon would have different DNA sequences.
- (4) Genetically modified salmon and wild salmon would have identical DNA sequences.

5 A farmer stopped maintaining a field that was once used to grow crops. Over time, the field eventually became a forest. These changes best illustrate the process of

- (1) ecological succession
- (2) nutrient recycling
- (3) decomposition
- (4) competition

6 During a woman's menstrual cycle, ovulation occurs and an egg is released. This process is important because it allows for

- (1) eggs to be produced by mitosis and be fertilized by a sperm
- (2) sperm to fertilize the egg in the uterus
- (3) multiple sperm to fertilize one egg, which then forms the placenta
- (4) the egg to leave the ovary and be fertilized by a sperm

7 The primary function of estrogen and progesterone is to

- (1) regulate growth
- (2) control heart rate
- (3) monitor blood sugar levels
- (4) regulate reproductive cycles

8 Which characteristic is common to most types of cancer?

- (1) production of low levels of ATP
- (2) inadequate levels of antigens
- (3) rapid and uncontrolled cell division
- (4) destruction of red blood cells

9 The human body fights an infection when a pathogen is detected. As a result, the pathogen stimulates the production of

- (1) bacteria
- (2) antibodies
- (3) vaccines
- (4) antibiotics

10 Levels of organization in humans are represented below.

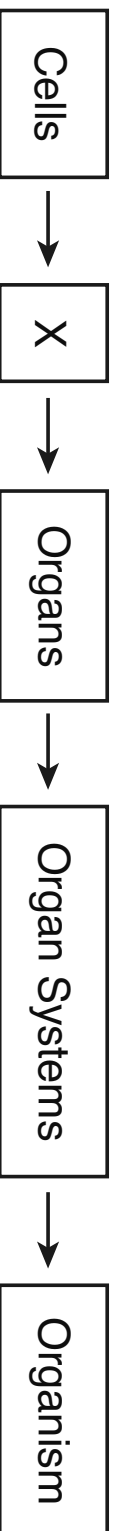

Level X most likely represents

- (1) molecules
- (2) organelles
- (3) tissues
- (4) ribosomes

11 A biological process is represented below.

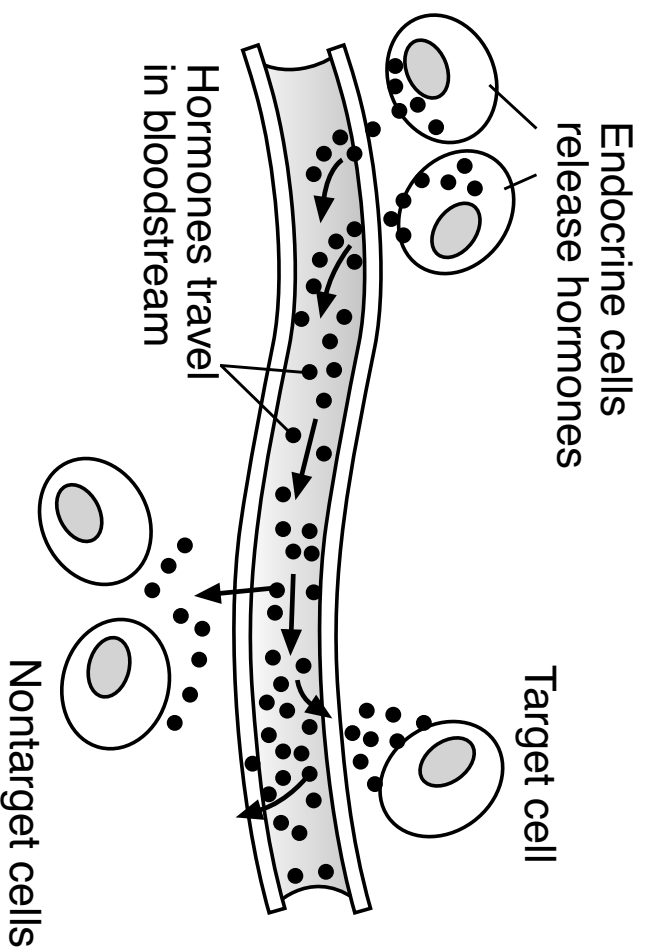

The reason the hormones affect the target cell and *not* the other cells is that the

- (1) hormone provides energy only for the target cell
- (2) target cell has specific receptors for the hormone
- (3) nontarget cells produce antibodies that block the hormone
- (4) hormones can only leave the bloodstream near the target cell

12 The diagram below represents one of a number of different types of mutations that can occur in DNA.

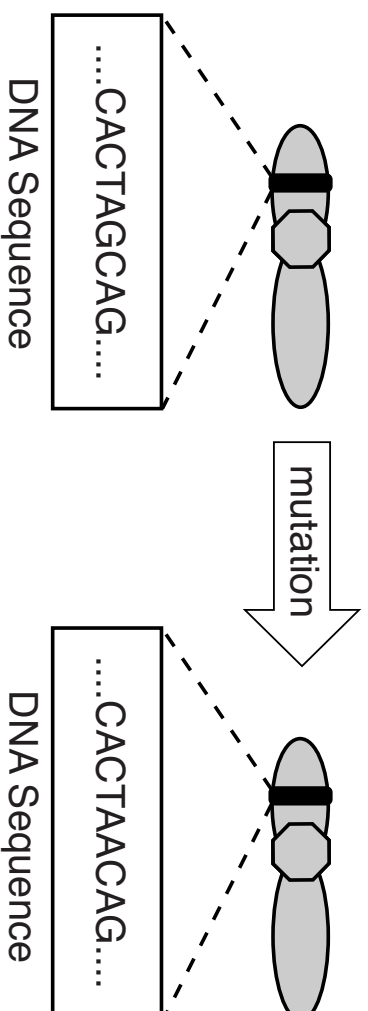

This mutation can best be described as the

- (1) pairing of an adenine (A) base with thymine (T)
- (2) the insertion of an adenine (A) base into both strands of the DNA molecule
- (3) the substitution of an adenine (A) base for guanine (G)
- (4) deletion of an adenine (A) base from the DNA molecule

13 After digesting the nutrients from a meal high in carbohydrates, the body

- (1) releases insulin to return the blood sugar levels to normal
- (2) secretes enzymes to absorb starch into the intestines
- (3) produces water to maintain dynamic equilibrium in the blood
- (4) maintains homeostasis by increasing wastes produced in muscle cells

14 The diagram below represents a pair of guard cells changing shape, reducing the size of the stomatal opening in a leaf.

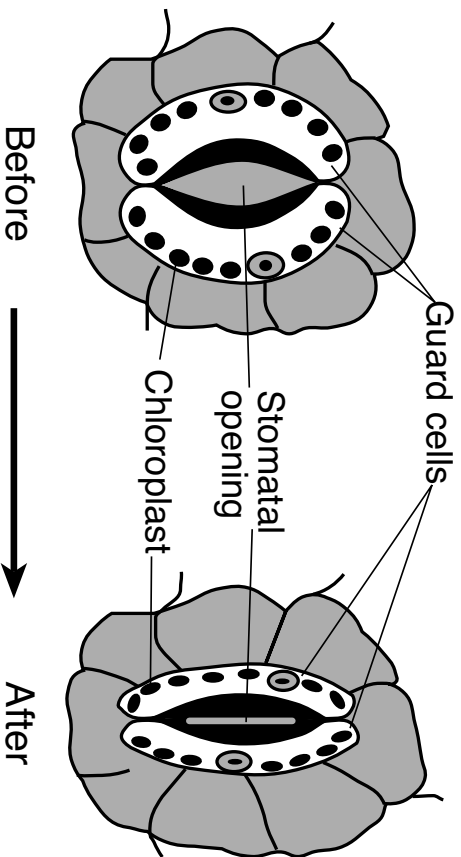

Source: Adapted from: <http://o.quizlet.com>

This is an adaptation that benefits plants by

- (1) increasing the flow of liquid water into leaves, which increases the rate of food and oxygen production
- (2) regulating the flow of water vapor out of leaves, preventing excess water loss by the plant
- (3) increasing the flow of oxygen molecules into the leaves, which increases the rate of photosynthesis
- (4) preventing the flow of carbon dioxide into the leaves, which would reduce the rate of respiration

15 Experiments in mice show that a guardian gene that protects against type 1 diabetes can be altered by exposure to antibiotics during development. The exposure alters the gut bacteria, leading to a loss of the guardian gene's protection. The loss of this protection most directly interferes with

- | | |
|-----------------|------------------|
| (1) homeostasis | (3) reproduction |
| (2) excretion | (4) respiration |

GO RIGHT ON TO THE NEXT PAGE →

16 A food web is represented below.

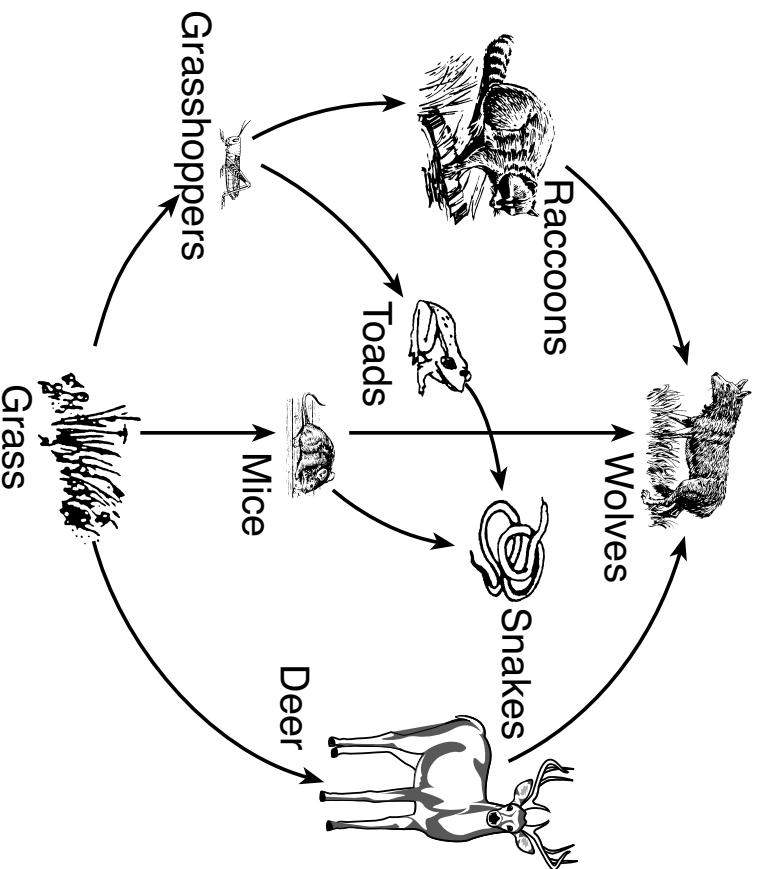

Which organism is correctly paired with its role in the ecosystem?

- (1) The grass is both a consumer and a decomposer.
- (2) The toads function as consumers and autotrophs.
- (3) The grasshoppers function as consumers and heterotrophs.
- (4) The snakes are both consumers and herbivores.

17 Many adults lack the ability to digest the milk sugar, lactose. Often, this is due to the insufficient production of the enzyme lactase, which breaks down lactose. This is not due to an allergy to milk. Milk allergies are different because they

- (1) are often not harmful to the person
- (2) result in a build-up of the substance in the body
- (3) are the result of the digestive system attacking the substance
- (4) result from an overreaction of the immune system to a harmless substance

18 One reason energy must be constantly added to a stable ecosystem is because some energy is

- (1) lost at each feeding level
- (2) incorporated into fossil fuels
- (3) destroyed by decomposers
- (4) digested by herbivores

19 Which statement best illustrates direct competition within a species?

- (1) A chipmunk is caught and eaten by a hungry fox.
- (2) A deer attempts to escape a mountain lion that is chasing it.
- (3) Two muskrats mate and produce a litter of offspring.
- (4) Several squirrels eat acorns from the oak tree where they live.

20 After a kidney transplant, special medications are taken. Otherwise, the patient's immune system might react to the transplanted kidney by

- (1) producing specialized proteins that would attack the kidney
- (2) signaling the body to synthesize new DNA molecules
- (3) stimulating the circulatory system to attack red blood cells
- (4) stimulating the kidney to produce reproductive hormones

21 Information that scientists are able to obtain from the fossil record includes

- (1) confirmation that Earth is 4.5 million years old
- (2) data supporting the hypothesis that animal species do not change over time
- (3) the exact means by which life on Earth began
- (4) evidence about past environments and the history of life

22 Fire ants have a powerful venom that is deadly to the small animals they eat. The deadly venom has reduced the populations of birds who build nests on the ground.



Source: <http://www.sbs.utexas.edu/fireant/>

The relationship between fire ants and ground-nesting birds is an example of

- (1) producer/consumer
- (2) predator/prey
- (3) scavenger/decomposer
- (4) parasite/host

23 When an altered ecosystem is left undisturbed, the most likely result would be

- (1) the gradual evolution of all of the original species
- (2) a rapid return to the original ecosystem
- (3) the elimination of all of the predator species
- (4) a gradual shift toward a stable ecosystem

24 Dead zones are areas found in the oceans and some large lakes where there is not enough oxygen to support life. Algae blooms occur when excess nutrients are introduced as pollutants from fertilizers, sewage-treatment plants, and the burning of fossil fuels. When the algae die and undergo decay, bacteria rapidly use up the oxygen in the area. Which human activity would most likely result in a *decrease* in the size and number of dead zones?

- (1) irrigating fields and lawns to increase runoff into the ocean and rivers
- (2) building more coal-fired electrical generating plants
- (3) reducing the use of chemicals on farm fields and golf courses
- (4) constructing more sewage-treatment plants on the shores of lakes and rivers

25 A recent study found high levels of the toxic industrial pollutant mercury in the feathers of some songbirds. Those birds sang shorter, simpler versions of the songs they use to attract mates. Which statement regarding this finding is supported by the study?

- (1) Mercury pollution will result in the extinction of all songbirds.
- (2) Mercury prevents songbirds from obtaining required nutrients.
- (3) Human activities usually affect the smallest animals in ecosystems.
- (4) Human activities can have negative effects on a species.

26 Which row in the chart below shows the connection between processes, structures, and hormones involved in the formation of an embryo?

| Row | Process | Structure Involved | Hormone Involved |
|------------|------------------|---------------------------|-------------------------|
| (1) | differentiation | lungs | insulin |
| (2) | gamete formation | testes | testosterone |
| (3) | union of gametes | cell nuclei | insulin |
| (4) | respiration | lungs | estrogen |

GO RIGHT ON TO THE NEXT PAGE →

27 A food web and an energy pyramid are represented below.

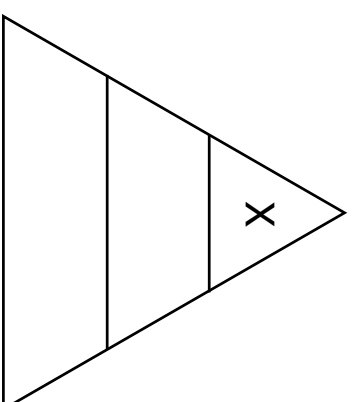
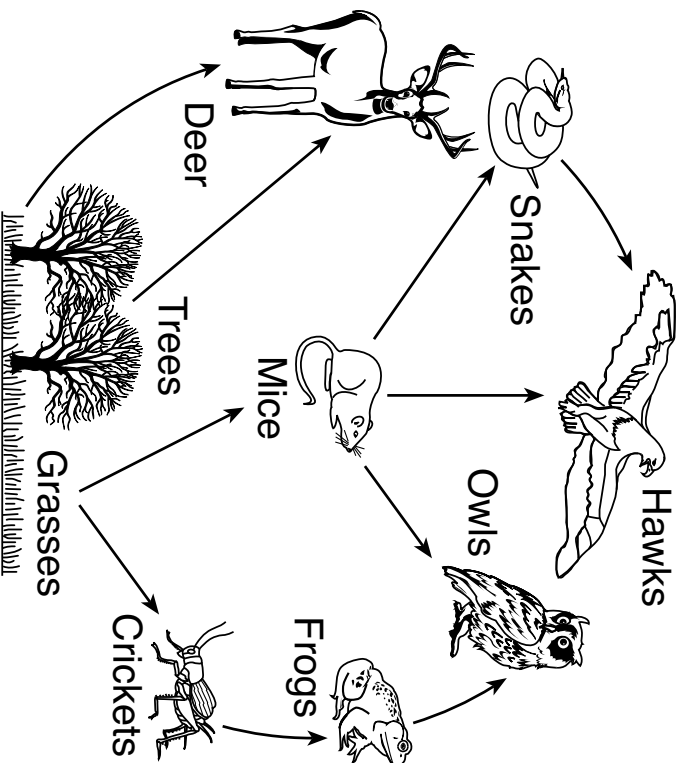

A group of organisms from the food web that would be found at level X of the energy pyramid is the

- (1) owls
- (2) deer

- (3) trees
- (4) crickets

28 It may be possible to bring back some extinct species using recent advances in genetic technology. Opinions regarding this issue are split within the scientific community. The table below summarizes some of the arguments on both sides.

| Pro | Con |
|---|--|
| <ul style="list-style-type: none">• It would increase the biodiversity of an ecosystem.• It would bring back organisms that are extinct. | <ul style="list-style-type: none">• The organisms that are brought back will compete with existing species.• The process is very expensive. |

The arguments made by both sides provide evidence that

- (1) genetic technology is the best way to correct the damage humans have done to the environment
- (2) the introduction of genetic technology will benefit all organisms equally
- (3) any new technology that increases the biodiversity of the area should be used
- (4) the use of new technology requires decisions based on an assessment of costs, benefits, and risks

29 Which statement best explains the purpose of the microorganisms in this aquarium?

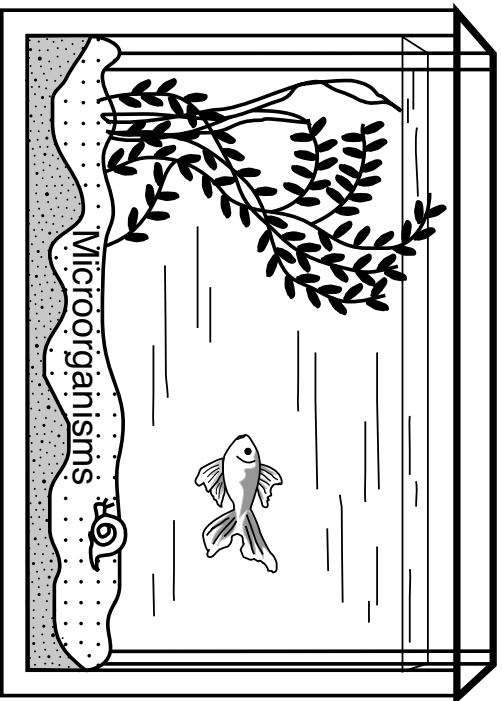

- (1) Microorganisms recycle nutrients that support the ecosystem.
- (2) Microorganisms recycle the energy in this ecosystem.
- (3) Microorganisms are a source of food for the plant.
- (4) Microorganisms are an abiotic factor important for decomposition.

30 A new species of floating photosynthetic algae was accidentally introduced into a pond ecosystem. It gradually replaced all the original algal species. A possible reason for the replacement could be that the new species

- (1) outcompeted the original algae populations for prey present in the ecosystem
- (2) required more resources than the original algae populations in the pond
- (3) outcompeted the original algae populations for abiotic factors
- (4) is less adapted to the pond ecosystem than the original algae populations

GO RIGHT ON TO THE NEXT PAGE ➡

Part B-1

Answer all questions in this part. [13]

Directions (31–43): For *each* statement or question, record on the separate answer sheet the *number* of the word or expression that, of those given, best completes the statement or answers the question.

31 The process of meiotic division in human females is represented below.

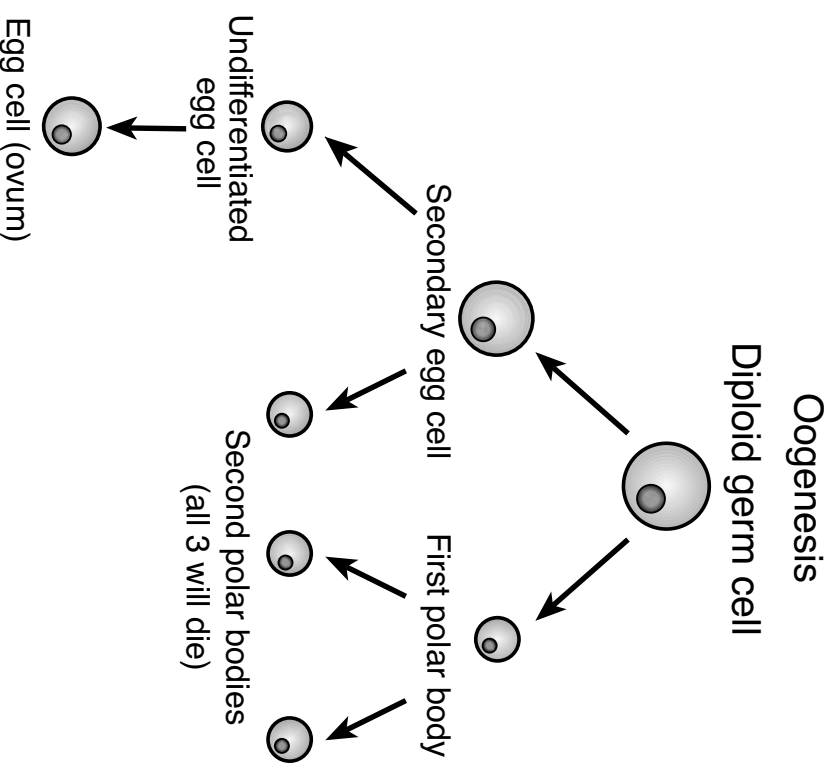

Source: Adapted from <http://bio-education.weebly.com/uploads>

Question 31 continued

This process normally produces

- (1) one functional gamete with one-quarter of the genetic information found in the diploid germ cell
- (2) one functional gamete with one-half of the genetic information found in the diploid germ cell
- (3) four functional gametes, each with one-quarter of the genetic information found in the diploid germ cell
- (4) four functional gametes, each with one-half of the genetic information found in the diploid germ cell

GO RIGHT ON TO THE NEXT PAGE →

32 A student read that liquid extracted from an *Aloe vera* plant promotes the healing of burned tissue. She decided to investigate the effect of different concentrations of *Aloe vera* extract on the regeneration (regrowth of lost or damaged tissue) rate in planaria. Planaria are small flatworms known for their ability to regenerate.

Planaria Regeneration

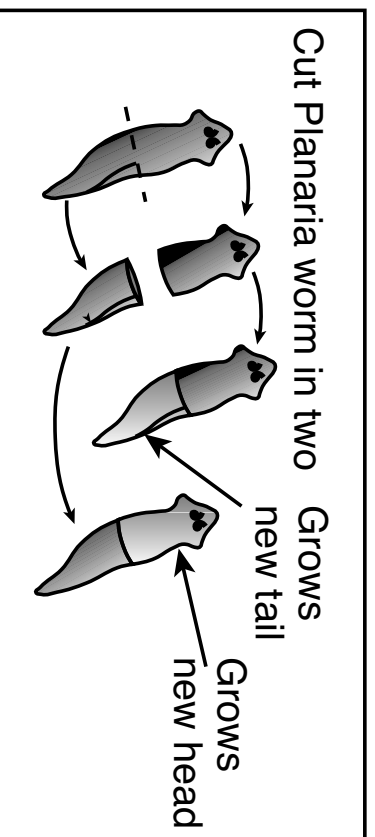

Source: Adapted from
<https://goo.gl/images/4wfcYv>

The student used a sterile scalpel to cut each of 30 planaria in half. This gave her 10 heads and 10 tails for each of three experimental groups. The planaria were kept in separate Petri dishes in the same amount of water and at the same temperature. Group 1 received 0% *Aloe vera* extract, Group 2 received a 20% concentration of the extract, and Group 3 received a 40% concentration. On days 7, 10, and 14, she recorded the amount of tissue regeneration in all three groups. She observed that the group with 20% *Aloe vera* added regenerated more slowly than the group with 40% added.

A reasonable inference based on these results would be that

- (1) *Aloe vera* affected the rate of cell division, resulting in an increased rate of regeneration
- (2) the control group, which received no *Aloe vera*, did not regenerate
- (3) if she applied 30% *Aloe vera* to a group, it would regenerate tissue more rapidly than the 40% group
- (4) the application of *Aloe vera* to earthworms would have no effect on tissue regeneration

33 The graph below represents the rate of a chemical reaction involving a particular human enzyme that breaks down starch.

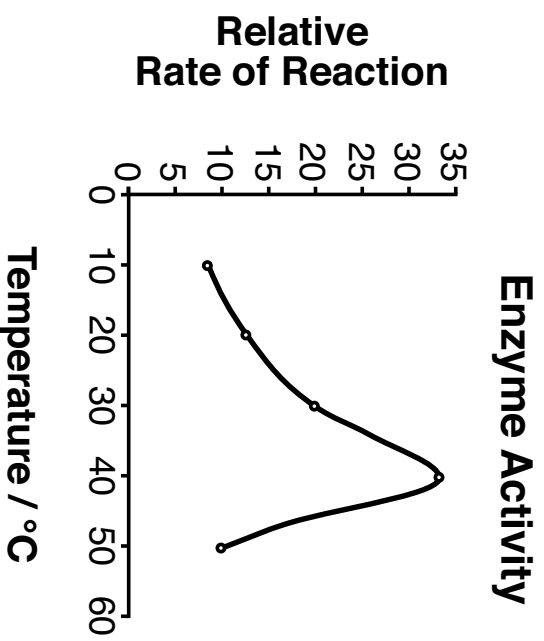

Source: Adapted from <http://mygmascience.files.wordpress.com/2011/11/enzyme-rate-of-reaction1.jpg>

The most likely reason the action of the enzyme *decreases* after 40°C is that

- (1) the DNA in the enzyme mutates and can no longer break down the starch
- (2) enzymes die after working for a long period of constant activity in the body
- (3) the shape of the enzyme changes due to environmental conditions
- (4) as the temperature of the enzyme rises, the pH of the environment changes, deactivating the enzyme

34 Researchers studied the relationship between lichen nitrogen content and the growth of lichens on trees. They recorded the amount of growth after determining the percentage of the tree that was covered in lichens. Their data are shown in the graph below.

Lichen Nitrogen Content and Tree Coverage

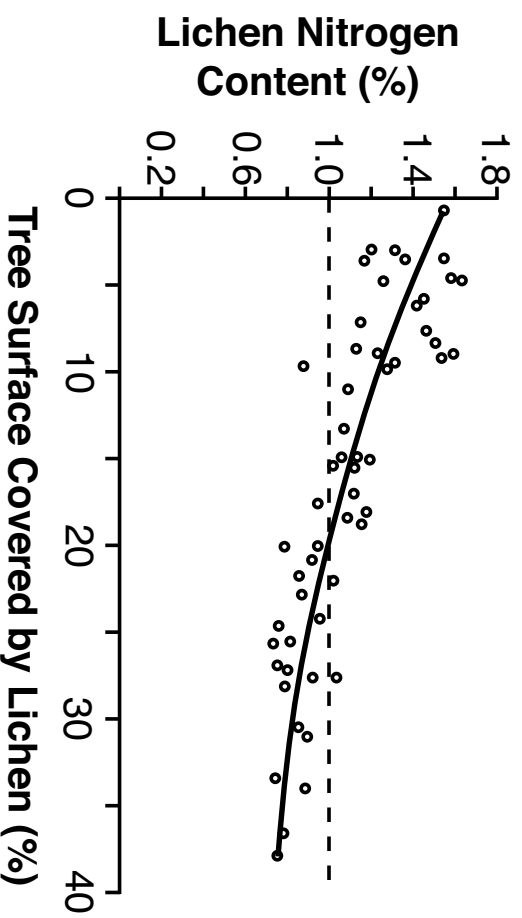

Source: McDermott, Amy, "Sentinels of Forest Health,"
Science News, Nov. 26, 2016, pp.20-23

Which statement best describes the relationship between the nitrogen content and the growth of the lichen?

- (1) As nitrogen content in the lichen increases, the growth of the lichen increases.
- (2) As nitrogen content in the lichen decreases, the growth of the lichen decreases.
- (3) As nitrogen content in the lichen decreases, the growth of the lichen increases.
- (4) There is not a clear relationship between the amount of nitrogen in the lichen and growth.

35 Scientific claims should be questioned if

- (1) peer review was used to examine the claims made by scientists
- (2) the experimental results cannot be repeated by other scientists
- (3) conclusions follow logically from the evidence
- (4) the data are based on samples that are very large

36 Organisms living in a forest ecosystem rely on the Sun as a source of energy for metabolic processes. The following events occur as energy is captured by a plant and used in the metabolic processes of an herbivore.

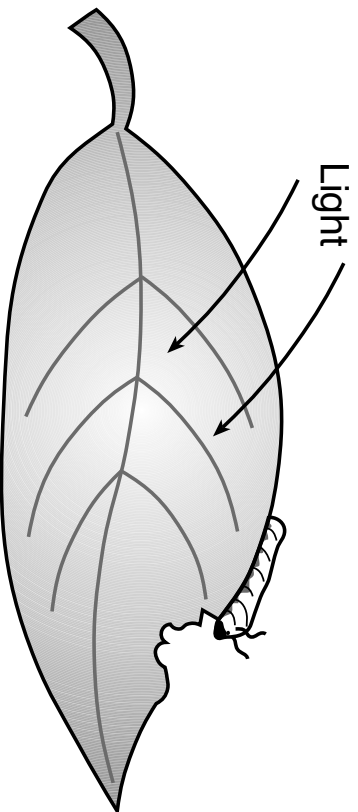

- [A] Energy is released from chemical bonds.
- [B] Energy is stored in large organic molecules.
- [C] Energy is transferred to molecules of ATP.
- [D] Energy is absorbed by plant cells.

The most likely order in which these events occur is

- (1) [A] – [D] – [B] – [C]
- (2) [B] – [A] – [C] – [D]
- (3) [D] – [A] – [B] – [C]
- (4) [D] – [B] – [A] – [C]

Base your answer to question 37 on the graph below and on your knowledge of biology. The graph shows the carbon dioxide (CO₂) concentration of the atmosphere since the year 1000.

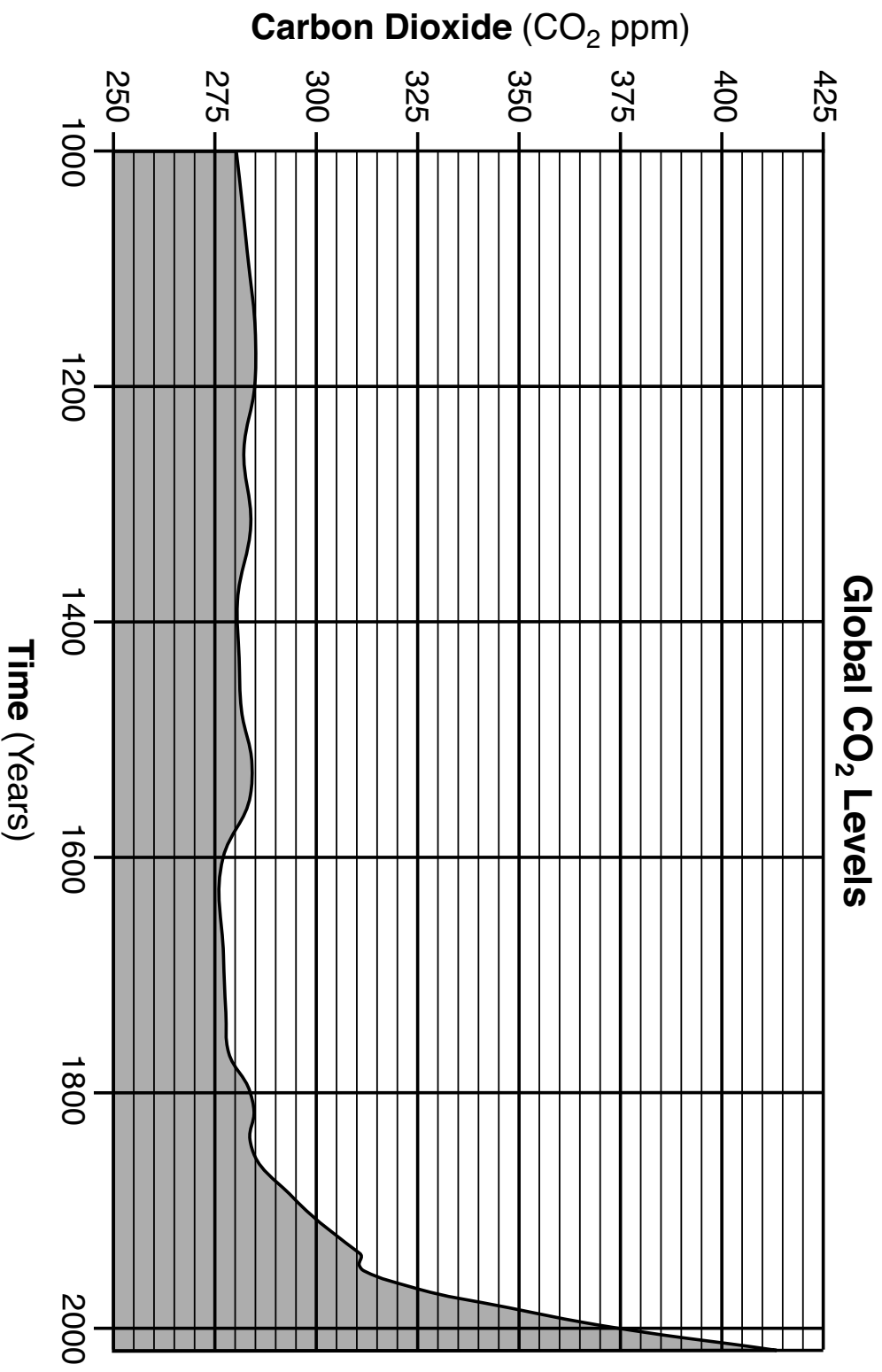

Source: Adapted from <https://www.co2.earth/co2-ice-core-data>

37 What was the approximate change in CO₂ level from the year 1000 to the year 2000?

- (1) an increase of 135 ppm
- (2) an increase of 95 ppm
- (3) a decrease of 135 ppm
- (4) a decrease of 95 ppm

Base your answers to questions 38 and 39 on the diagram below and on your knowledge of biology. The diagram represents a series of events that occur within living organisms.

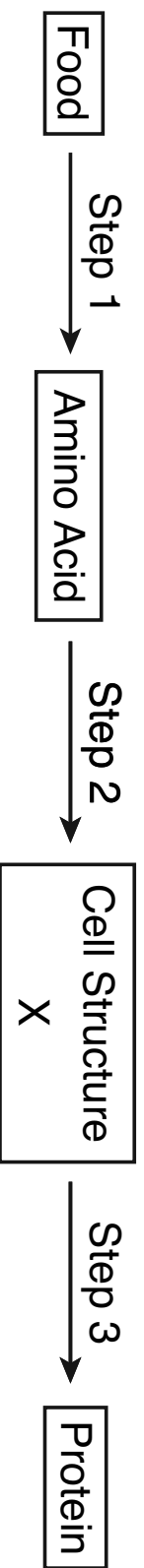

38 The process that occurs at Step 1 is

- (1) respiration
- (2) circulation

- (3) excretion
- (4) digestion

39 Cell structure X is a

- (1) ribosome
- (2) vacuole

- (3) cell membrane
- (4) mitochondrion

GO RIGHT ON TO THE NEXT PAGE →

40 Two types of cells from an individual are represented below.

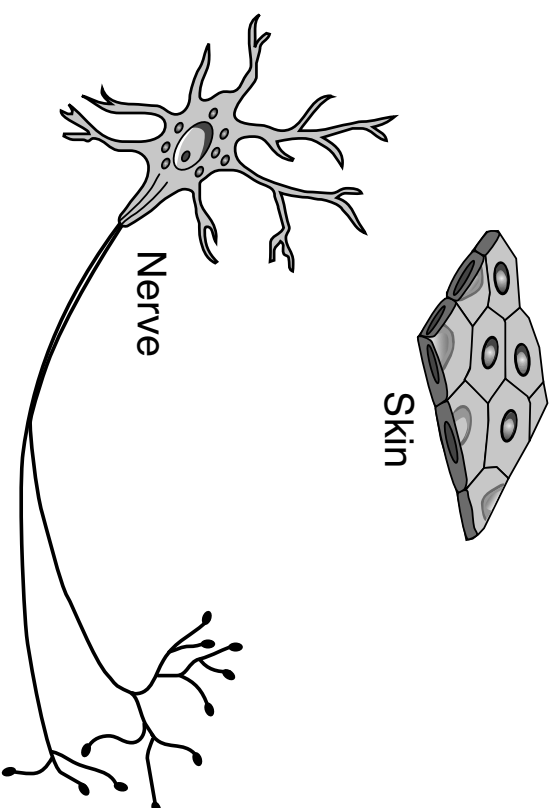

Question 40 is continued on the next page

Question 40 continued

Which model, that shows only some of the chromosomes in each of the two types of cells, best explains why these cells are so different?

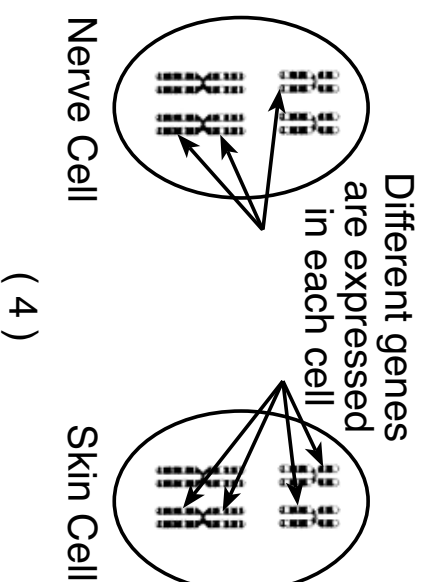
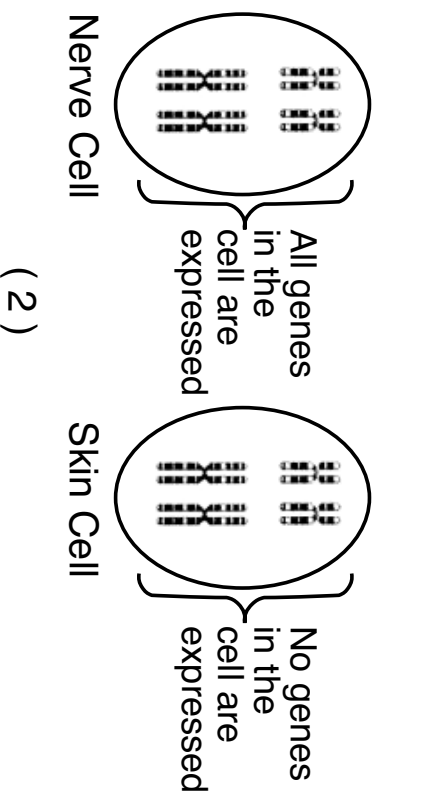
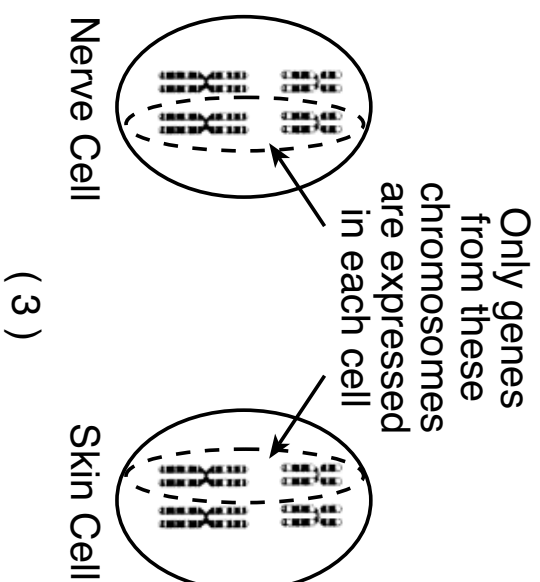
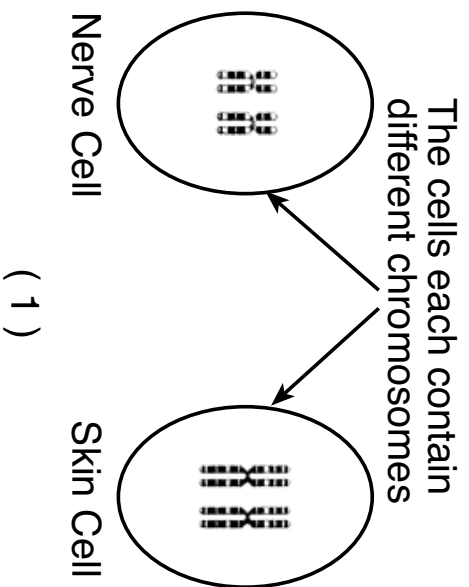

Base your answers to questions 41 and 42 on the passage below and on your knowledge of biology.

Bed Bugs... They're Back!

Bed bugs aren't just a problem from centuries past. Bed bug infestations have been increasing for more than a decade. This has been largely due to the insects' ability to quickly develop resistance to the insecticides used to kill them.

Bed bugs have a tough outer coat, called a cuticle, which helps protect them. Researchers have found that some resistant bed bugs have gene mutations that allow the cuticle to produce substances that break down the insecticides. Others have gene mutations that direct the building of biological pumps, which allow the cuticle to pump the harmful insecticide out of the bug.

- 41 The substances which allow the bed bugs to break down insecticides and the biological pumps which remove the insecticides from the bed bugs are examples of
- (1) the failure of homeostasis
 - (2) genetic engineering
 - (3) biological adaptations
 - (4) selective breeding
- 42 A gene mutation resulting in insecticide resistance would most likely increase in the bed bug population because
- (1) more bed bugs will need to be resistant to the insecticide
 - (2) the insecticide-resistant bed bugs will survive and reproduce
 - (3) the bed bugs with the resistance gene will reproduce asexually
 - (4) spraying an insecticide will allow more bed bugs without mutations to survive
-

43 The graph below summarizes how effective the seasonal flu vaccine has been at preventing infection with the flu virus. The data were collected over a 13-year period.

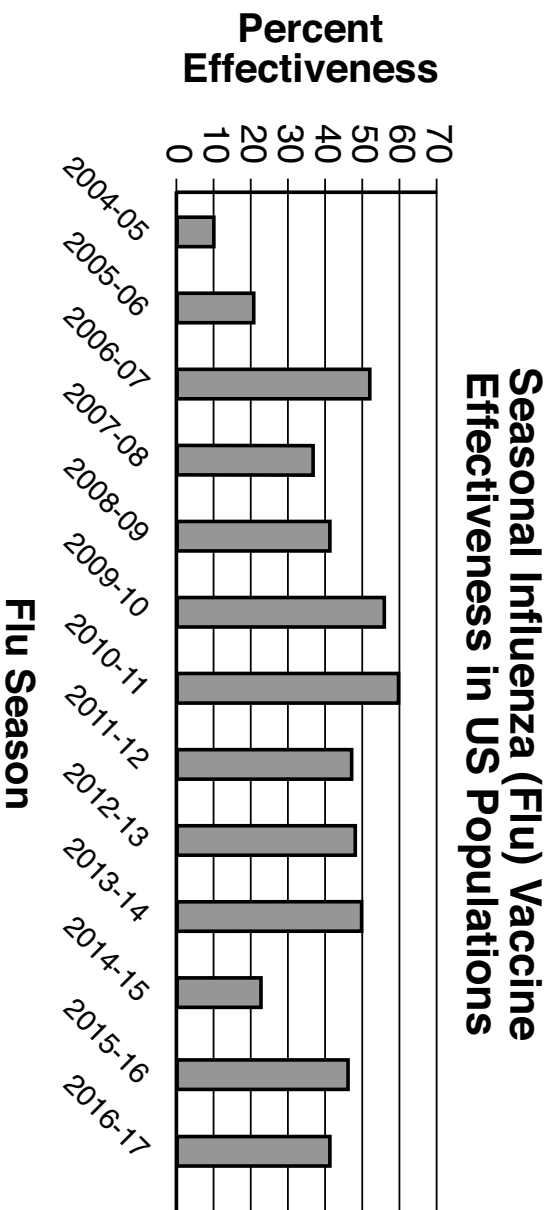

Source: <https://www.sciencenews.org/article/universal-flu-shot-may-be-nearing-reality>

Based on the data provided, a reasonable interpretation would be that

- (1) in 2004-2005, some individuals caught the flu from the vaccine
- (2) the virus mutated in 2014-2015, resulting in the vaccine being less effective
- (3) people have become immune to the flu vaccine over the 13-year period
- (4) the vaccine has become increasingly effective over the 13-year period

Part B-2

Answer all questions in this part. [12]

Directions (44–55): For those questions that are multiple choice, record on the separate answer sheet the *number* of the choice that, of those given, best completes each statement or answers each question. For all other questions in this part, follow the directions given and record your answers in the spaces provided in this examination booklet.

44 As part of an assignment, students were asked to record examples of genetic variation in their family. One student listed the following:

- I am the youngest in my family.
- I have brown eyes.
- I have a scar.
- I am a vegetarian.

Only one of these statements is an example of a genetic trait. Identify the genetic trait and support your answer. [1]

Base your answers to questions 45 through 49 on the information and data table below and on your knowledge of biology.

Overfishing of Newfoundland Cod

When fishing results in small catches, it is said that the species has been overfished. Over the last 75 years, ocean fish populations have dropped by almost 90%. The data below show the approximate amount, in thousands of tons, of Newfoundland cod caught each year from 1970 to 1995.

**Approximate Amount of Newfoundland
Cod Catches, 1970-1995**

| Years | Tons x 10³ of Newfoundland Cod Caught |
|--------------|---|
| 1970 | 1500 |
| 1975 | 1300 |
| 1980 | 600 |
| 1983 | 700 |
| 1985 | 300 |
| 1987 | 400 |
| 1990 | 210 |
| 1993 | 100 |
| 1995 | 50 |

Directions (45-46): Using the information in the data table, construct a line graph on the grid provided on the next page, following the directions below.

45 Mark an appropriate scale, without any breaks in the data, on each labeled axis. [1]

46 Plot the data on the grid. Connect the points and surround each point with a small circle. [1]

Example:

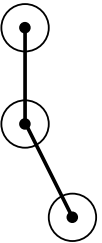

The grid for questions 45-46 is on the next page.

Catch in Tons X 10³

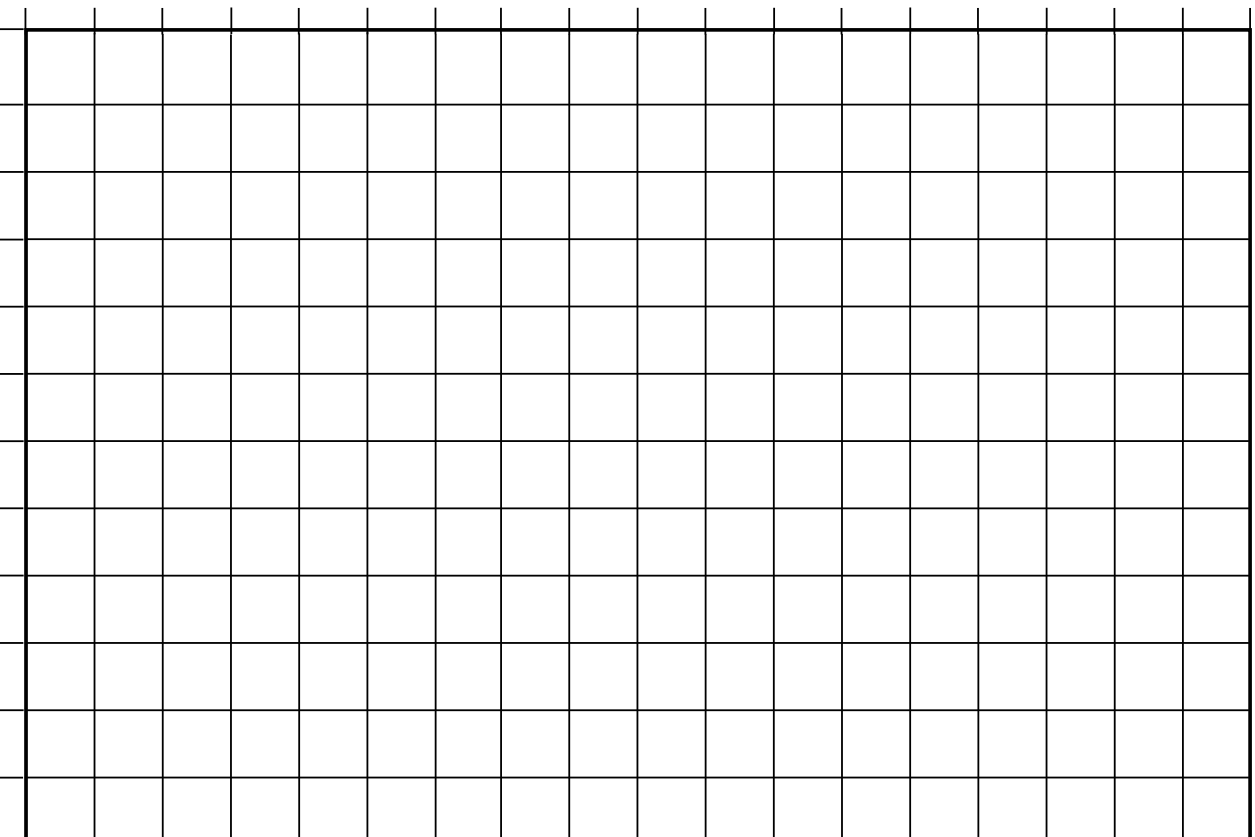

Years

Note: The answer to question 47 should be recorded on your separate answer sheet.

47 During which five-year span did the largest drop in fishing occur?

- (1) 1970 and 1975
- (2) 1975 and 1980
- (3) 1980 and 1985
- (4) 1990 and 1995

48 Other than maintaining an adequate food supply for humans, state *one* other advantage of *not* overfishing the oceans. [1]

Note: The answer to question 49 should be recorded on your separate answer sheet.

49 In 2003, biologists encouraged nations to decrease the number of fish caught in order to help global fish populations recover. This seems to be helping some fish populations to increase. This increase in the size of some fish populations is a result of human

- (1) actions that killed many of the predators of these fish populations
 - (2) decisions that weighed the need for food with the need to maintain fish populations
 - (3) activities that are increasing the use of nonrenewable resources of the oceans
 - (4) decisions that are increasing the use of renewable ocean resources
-

GO RIGHT ON TO THE NEXT PAGE ➡

Base your answers to questions 50 and 51 on the information and diagram below and on your knowledge of biology.

The diagram illustrates the evolution of tetrapods. A tetrapod is a four-footed animal.

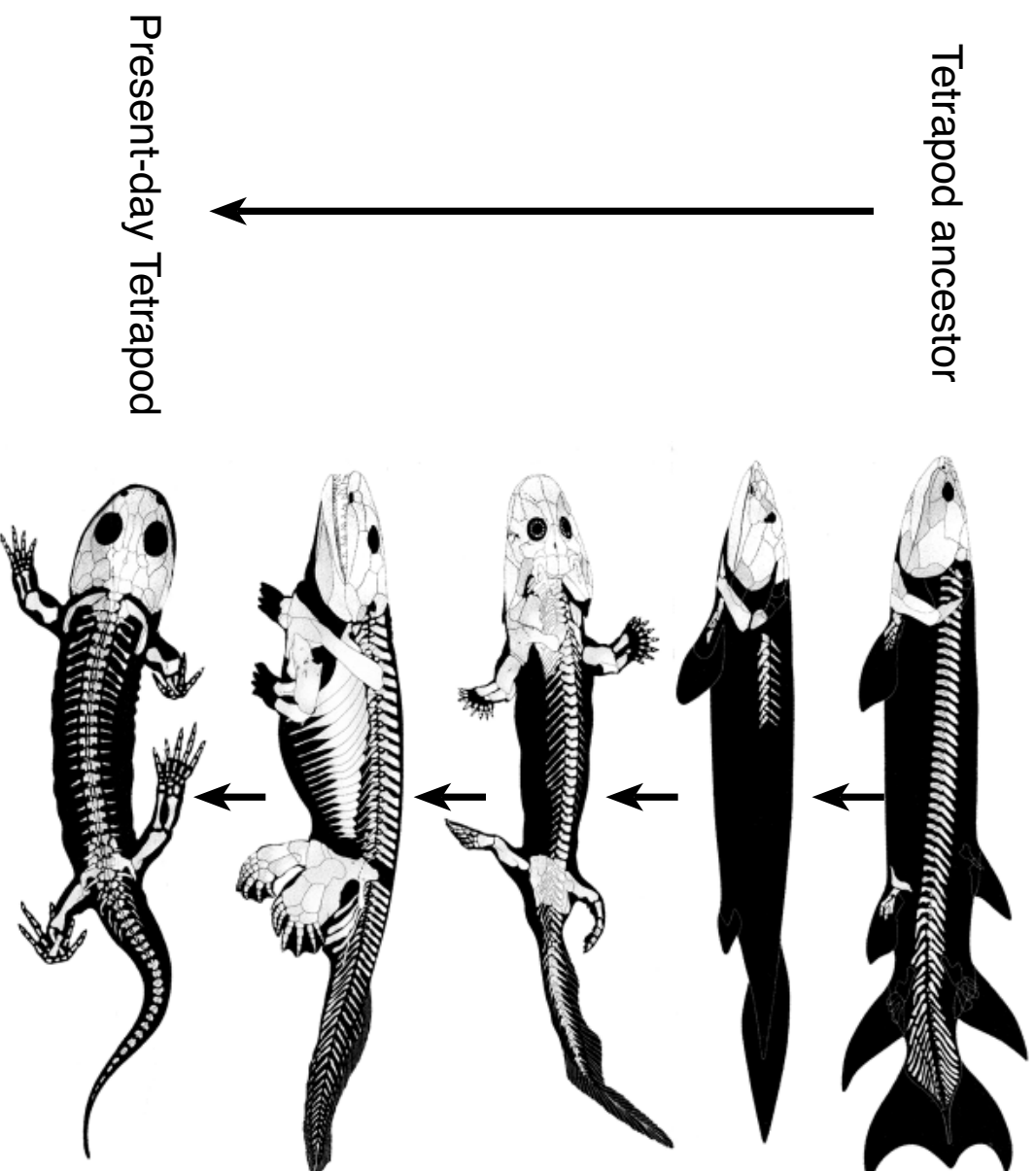

Source: Adapted from Coates, M., *Palaeobiology 2*, Briggs D. et al., eds., p.75, © 2001 Blackwell Publishing

Note: The answer to question 50 should be recorded on your separate answer sheet.

50 The changes observed over time occurred as the organisms

- (1) needed to change the habitat where they lived from land to water
- (2) needed to change the habitat where they lived from water to land
- (3) developed variations that made it possible for them to move from land to water
- (4) developed variations that made it possible for them to move from water to land

51 Describe *one* way scientists can determine the correct sequence of fossils that represents the ancestry of an organism such as a tetrapod. [1]

GO RIGHT ON TO THE NEXT PAGE →

Base your answers to questions 52 through 55 on the diagram and graph below and on your knowledge of biology.

The diagram represents some organisms in a pond food web. The graph shows the changes in the size of the bacteria population also present in the food web over time.

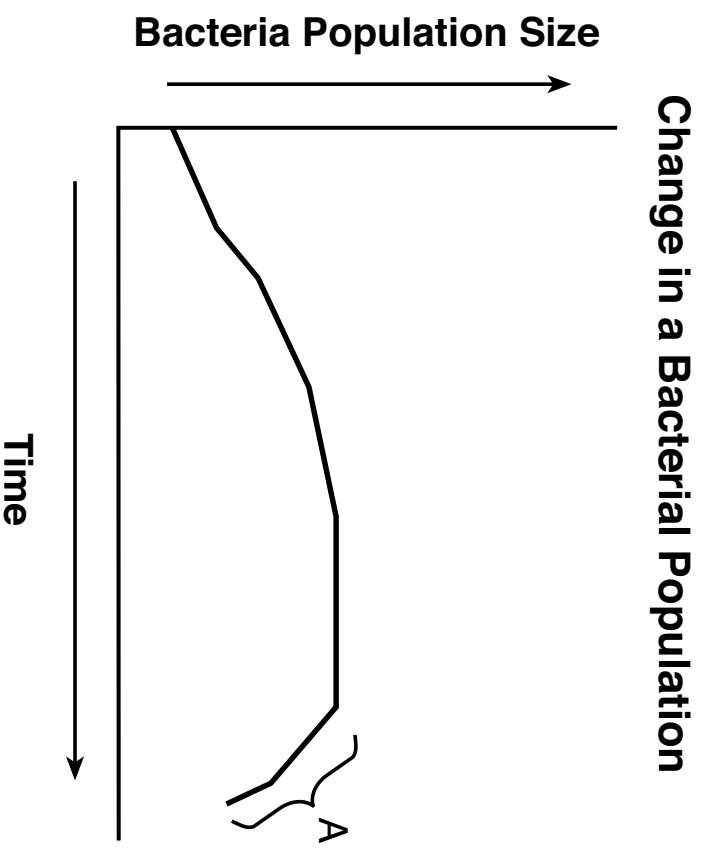
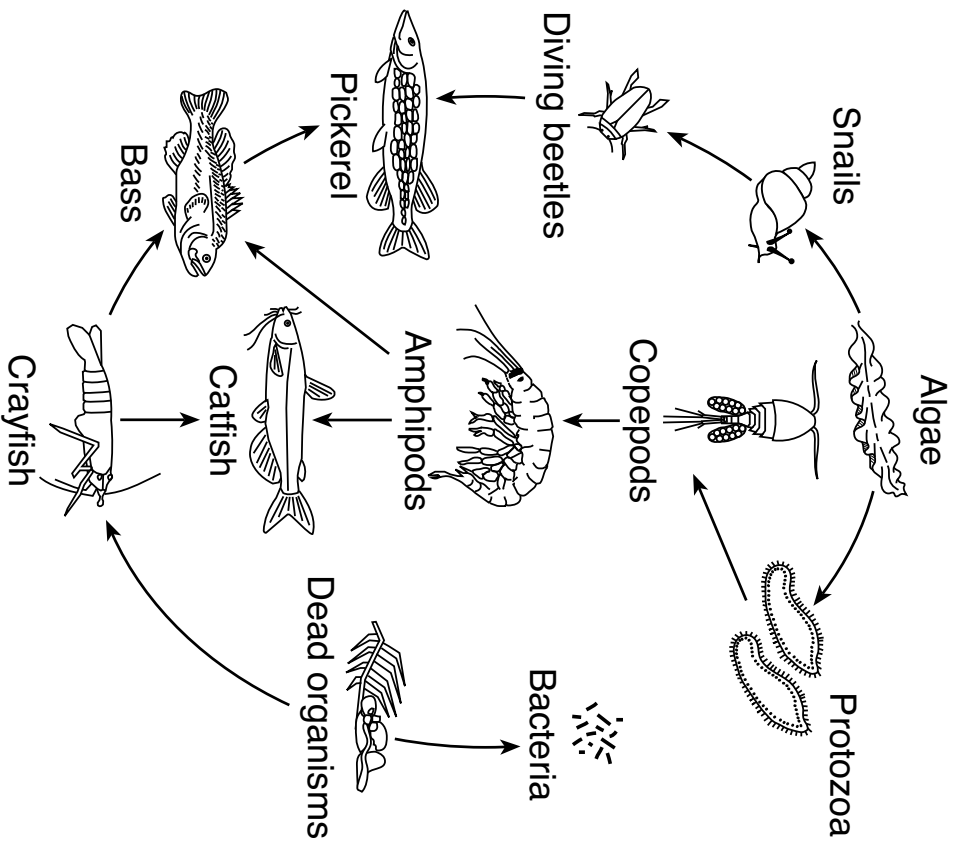

52 Identify the population represented in this food web that has the greatest amount of stored energy. [1]

53 State what would most likely happen to the bass population if a pesticide that was used in this ecosystem killed the entire pickerel population. Support your answer. [1]

54 Identify the role of the bacteria in this food web and state the importance of this particular role. [1]

55 State *one* possible reason for the change in the bacterial population size in the area labeled A on the graph. [1]

Part C

Answer all questions in this part. [17]

Directions (56–72): Record your answers in the spaces provided in this examination booklet.

Base your answers to questions 56 through 58 on the data table below and on your knowledge of biology.

Changes in Size of the Ozone Hole

| Year | Ozone Hole Area (million km²) |
|-------------|---|
| 1980 | 3.3 |
| 1985 | 18.8 |
| 1990 | 21.1 |
| 1996 | 26.9 |
| 2000 | 29.9 |
| 2005 | 27.2 |
| 2010 | 22.6 |
| 2017 | 19.6 |

Source: <https://ozonewatch.gsfc.nasa.gov>

In 1987 an agreement was reached called the Montreal Protocol, which limited the world's production of chemicals that could damage the ozone shield.

56 Identify *one* risk associated with the destruction of the ozone shield. [1]

57 Using evidence from the data table, explain whether or not the Montreal Protocol has been effective. [1]

58 Describe *one* possible *negative* consequence that is important to consider when an international agreement such as the Montreal Protocol is adopted. [1]

Base your answers to questions 59 through 62 on the information below, on the next page, and on your knowledge of biology.

Fungicides and Bumblebees



Source: Adapted from <https://polinizador.files.wordpress.com/2011/03/img670-6-18-07.jpg>

Bumblebees are extremely important in agriculture. They pollinate many flowering plants, including food crops such as tomatoes, pumpkins, and blueberries. The bees gather wet, sticky pollen from flowers and take it to their nests. Fungi, present on the pollen, keep it from spoiling. In the nest, bumblebee larvae feed on both the pollen and fungi.

Through his research, Dr. Shawn Steffan discovered that the stored pollen and nectar that bumblebee larvae feed on is rich in yeast, a type of fungus. Based on this observation, he proposed that the application of fungicides, chemicals that kill fungi, on agricultural crops could affect the quality of bumblebee food and ultimately the health of bumblebee colonies. He hypothesized that if the fungi associated with the pollen suffer, then the bumblebee larvae will also suffer.

Dr. Steffan designed an experiment in which five colonies of bumblebees only fed on flowers treated with fungicides. In five other colonies, the bumblebees only fed on flowers that were free of fungicides. At the conclusion of the experiment, the control-bee colonies averaged about 43 individuals. The colonies that fed on flowers with fungicides (and no fungus) averaged only about 12 individuals.

59 Using information from the reading, explain how the results of the experiment support Dr. Steffan's hypothesis. [1]

60 Dr. Steffan proposed that one way to protect the bees might be to only spray agricultural crops when they were not flowering. Explain how this would prevent harming bumblebee larvae. [1]

61 In addition to the use of pesticides, studies also show that bee species inhabiting smaller geographic areas are more sensitive to changes in climate. Explain how climate change could have a greater impact on bee species inhabiting smaller geographic areas than those inhabiting larger geographic areas. [1]

62 Explain why it is important to preserve bumblebee populations. [1]

63 Scientists build models based on what they know from previous research to develop testable hypotheses. Scientists Watson and Crick first constructed an incorrect triple-helix model of DNA with the bases (A, T, C, G) arranged on the outside of the molecule. Explain why their triple-helix model was valuable even though it was not correct. [1]

64 State *one* reason why a human heart muscle cell would probably contain a higher proportion of mitochondria than a skin cell. [1]

65 Phytoplankton are photosynthetic organisms that live in aquatic environments. Although microscopic, their vast numbers provide a plentiful resource for many aquatic food webs. Explain why populations like phytoplankton are required to sustain an aquatic food web. [1]

Base your answers to questions 66 through 68 on the information below and on your knowledge of biology.

How One Bull Cost the Dairy Industry \$420 Million

It all started with a bull named Chief. He had 16,000 daughters, 500,000 granddaughters, and 2 million great-granddaughters. Today, 14% of the genes present in Holstein dairy cows came from Chief.

Chief was popular because his daughters were fantastic milk producers. The problem is, he also had a single copy of a deadly mutation. The mutation spread undetected through the Holstein cow population and was responsible for the spontaneous death of 500,000 fetal calves. The loss of these calves cost the dairy industry \$420 million.

Over the past 35 years, using Chief's sperm, instead of sperm from an average bull, resulted in \$30 billion in increased milk production. Due to Chief's genetic contribution, the average dairy cow today produces four times more milk than a dairy cow in the 1960s.

Chief embodies the trade-offs associated with selective breeding.



Chief

Source: <https://www.progressivedairy.com>

66 Explain why using Chief to produce so many offspring is an example of selective breeding. [1]

67 Explain how the use of Chief to produce offspring had both advantages and disadvantages. [1]

68 Explain how genetic engineering could be used to improve the chance that more of Chief's offspring would survive. [1]

Base your answers to questions 69 through 72 on the information below and on your knowledge of biology.

The Tuskless Female Elephants of Gorongosa National Park

Elephants are large mammals that live in parts of Africa and Asia. They typically have tusks which are a pair of elongated teeth that the animals use to strip bark off of trees and dig holes to obtain water and minerals. Tusks are also used by males when they compete with each other to impress females during the mating season. Males born without tusks are at a high risk of being severely wounded during these competitions.

In several regions in Africa, elephants have been killed for their ivory tusks. The ivory can be sold for large sums of money, even though the sale of ivory is illegal in many parts of the world. During a 15-year civil war in Mozambique, many large-tusked elephants in Gorongosa National Park were killed and their ivory sold to buy arms and ammunition. The elephant population decreased during the war from over 2000 individuals to only a few hundred. Female elephants that had no tusks (an inheritable trait) made up only about 6% of the entire population before the war began.

When the war ended in 1992, the wildlife in the park was better protected against poaching. The elephant population has recovered fairly well, but a significant change has been noted: The tuskless female elephants that survived the civil war now make up more than 50% of the older female population in the park. About 33% of the female offspring that were born after the war are also tuskless. No tuskless males have been seen.

- 69 Explain how an elephant without the ability to grow tusks could be born into a population of elephants that all have tusks. [1]
-

70 At the start of the civil war, only about 6% of the female elephants had no tusks. Explain why over one-half of the females that survived the war had no tusks. [1]

71 Explain why so many (33%) of the female elephants born in the years after the war have no tusks. [1]

72 Even without poaching being a factor, explain why tuskless males are rarely seen. [1]

Part D

Answer all questions in this part. [13]

Directions (73–85): For those questions that are multiple choice, record on the separate answer sheet the *number* of the choice that, of those given, best completes each statement or answers each question. For all other questions in this part, follow the directions given and record your answers in the spaces provided in this examination booklet.

Base your answer to questions 73 and 74 on the information below, the scatter plot on the next page, and on your knowledge of biology.

Before watching a scary movie, the members of a theater audience agreed to have their heart rates monitored. They were asked to sit in silence for 10 minutes before the film began. The movie was then shown from beginning to end.

The scatter plot below summarizes the data collected by all of the heart monitors from ten minutes before the start of the movie to the end of the movie.

Scary-Movie Heart Rates

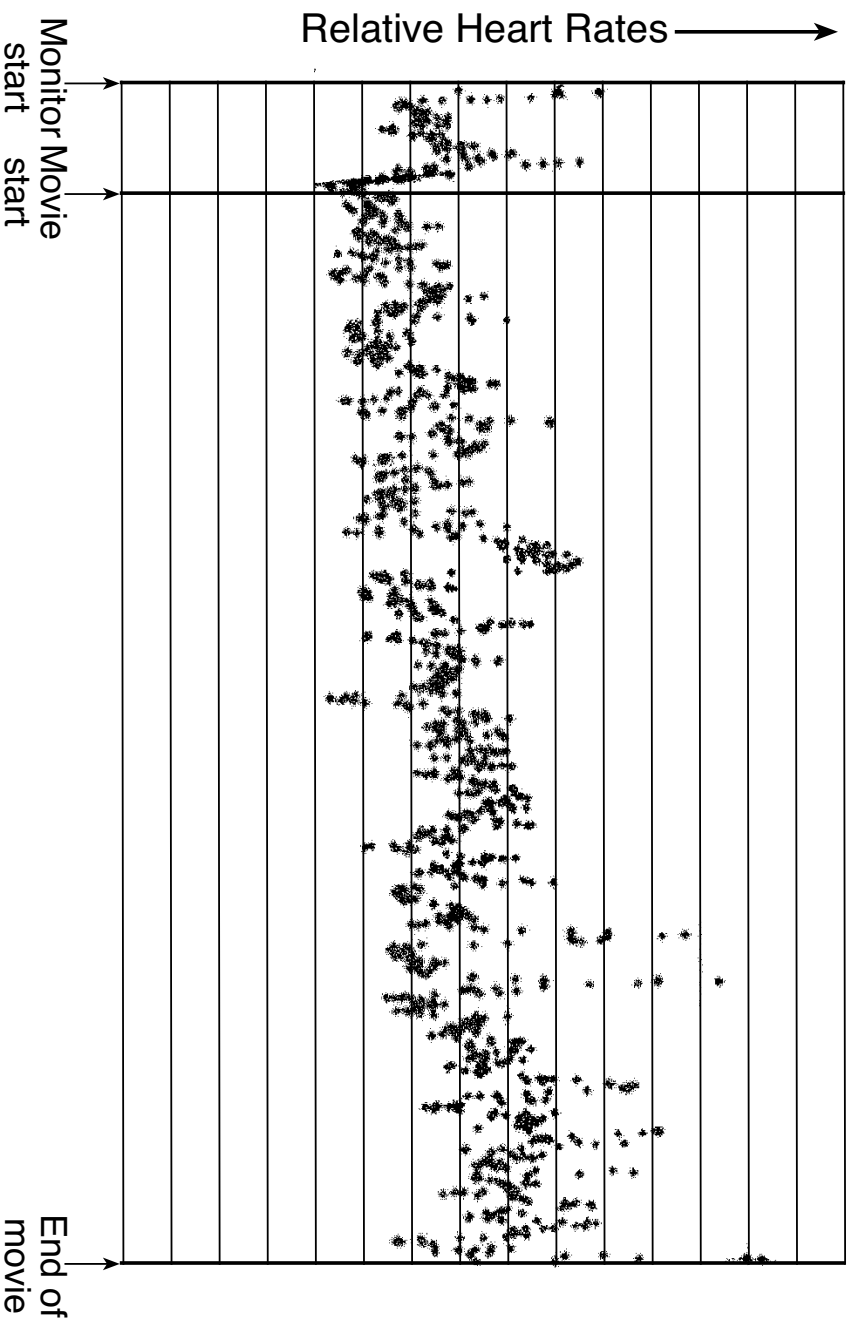

Source: <http://www.theguardian.com/film/filmblog/2014/sep/01/watched-horror-film-heart-rate-monitor-as-above-so-below>

Note: The answer to question 73 should be recorded on your separate answer sheet.

73 In this experiment, the dependent variable is the

- (1) heart rate of the audience members
- (2) scene being viewed by the audience
- (3) amount of time the movie played
- (4) number of viewers with heart-rate monitors

Note: The answer to question 74 should be recorded on your separate answer sheet.

74 Which is a possible hypothesis most likely being tested in this experiment?

- (1) Silence in a theater increases the heart rates of the audience members.
 - (2) The length of a movie causes changes in heart rate.
 - (3) Do heart rates increase when watching scary movies?
 - (4) Watching scary movies will increase the heart rates of audience members.
-

Note: The answer to question 75 should be recorded on your separate answer sheet.

75 A student filled two Petri dishes with a clear gel made with corn starch. He was given two unknown solutions (*A* and *B*) and was asked to determine which solution contained a chemical that digests starch.

Using a clean cotton swab, he dipped it into solution *A* and wrote a “?” invisibly onto the gel in one of the Petri dishes. He repeated the same procedure on the second Petri dish with a clean cotton swab he dipped in solution *B*.

Twenty minutes later, he added starch-indicator solution to the surface of both Petri dishes. The surface of the Petri dish with solution *A* added turned completely blue. Most of the surface of the Petri dish to which solution *B* was added was blue, except the “?” was clear. The results are illustrated on the next page.

Question 75 is continued on the next page.

Question 75 is continued.

Petri Dishes With Starch Gel After 20 Minutes

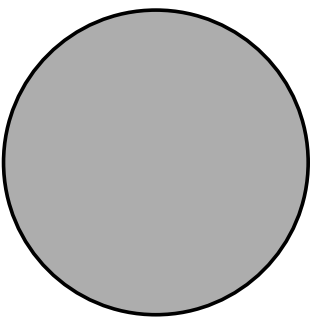

Petri dish swabbed
with solution A



Petri dish swabbed
with solution B

An observation that supports the student's conclusion that solution *B* contained a chemical that digests starch is that the

- (1) damp cotton swab absorbed some of the starch where it touched the gel
- (2) starch indicator changed the color of the gel to blue
- (3) area swabbed with solution *B* remained clear
- (4) chemical in the starch indicator reacted with the chemical in *B*

GO RIGHT ON TO THE NEXT PAGE →

Base your answer to question 76 on the information below, on the next page, and on your knowledge of biology. The diagram shows variations in the beaks (bills) of some finches on the Galapagos Islands.

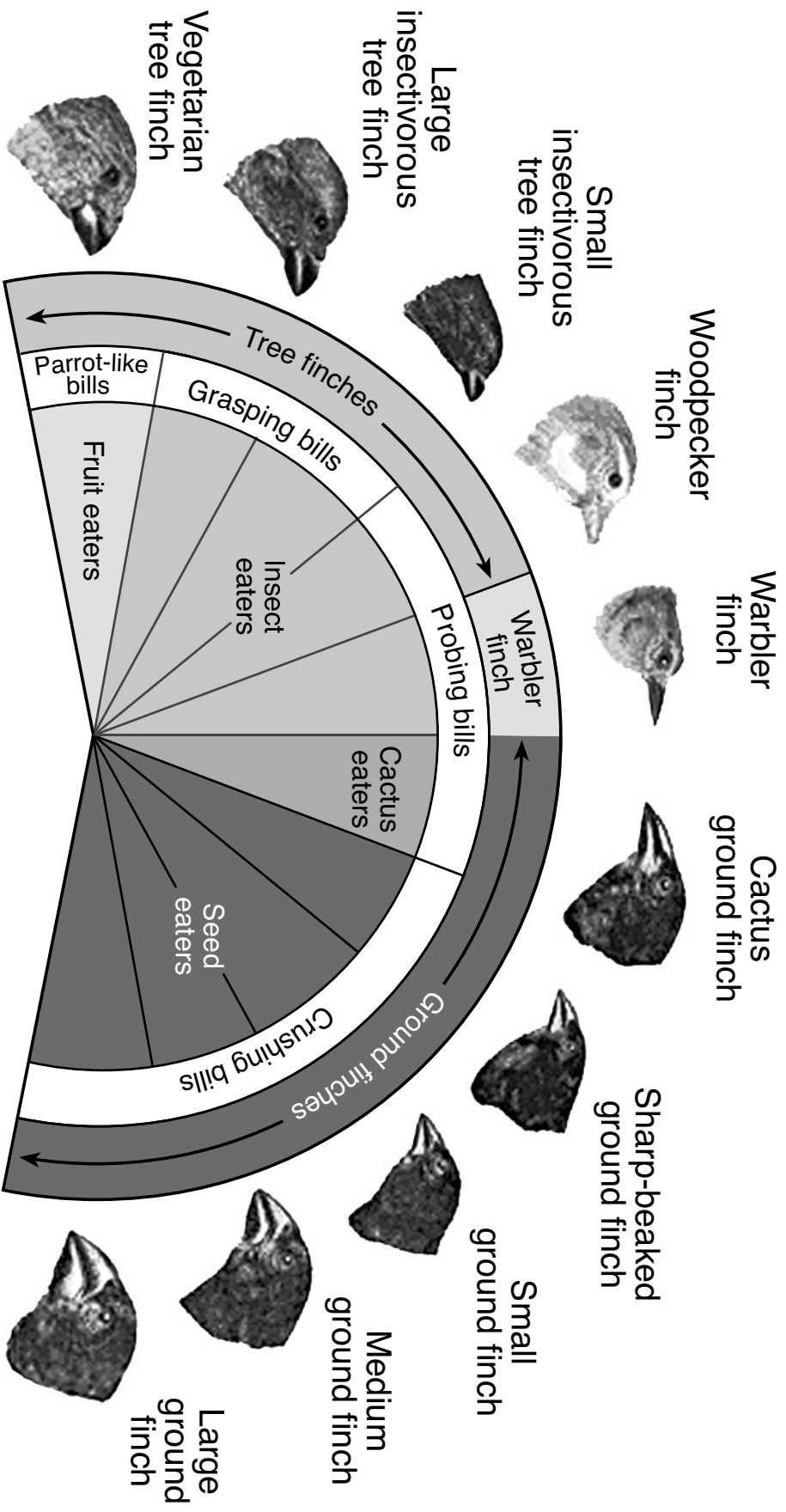

Source: www.pbs.org

The photographs of four different finch species that are found in the Galapagos are shown below.



A

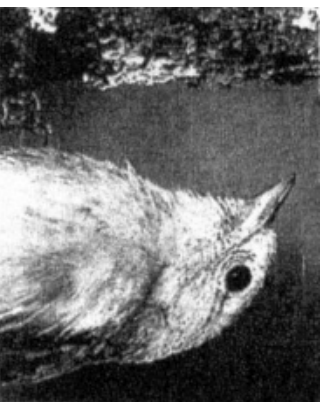

B



C

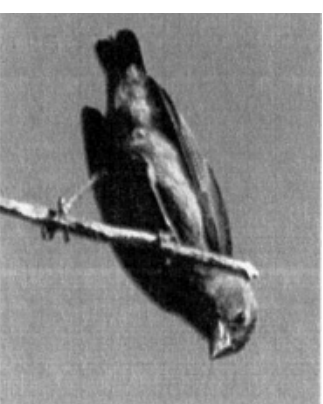

D

Source: *Biology*, Mader, Sylvia, McGraw-Hill, Boston, 2007, p.287, and Wikipedia

Note: The answer to question 76 should be recorded on your separate answer sheet.

76 Which row in the chart below correctly identifies one of these finches?

| Row | Finch | Beak Characteristic | Food Source | Species |
|-----|-------|---------------------|-------------|--------------------|
| (1) | A | Probing | Fruit | Large ground finch |
| (2) | B | Probing | Insects | Warbler |
| (3) | C | Parrot-like | Seeds | Cactus finch |
| (4) | D | Crushing | Fruit | Small ground finch |

Base your answer to question 77 on the diagram below and on your knowledge of biology.

The diagram represents three groups of red blood cells. Groups A and B were each placed in different solutions for the same period of time.

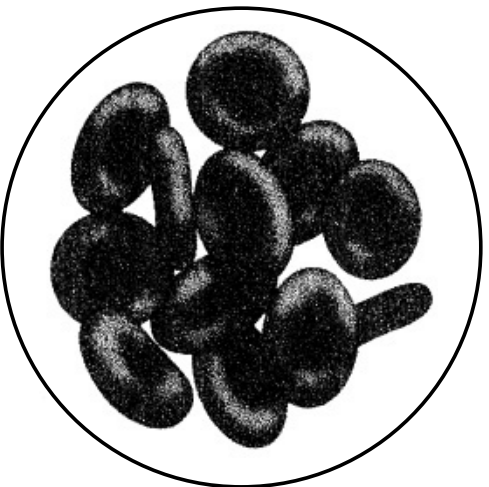

Normal

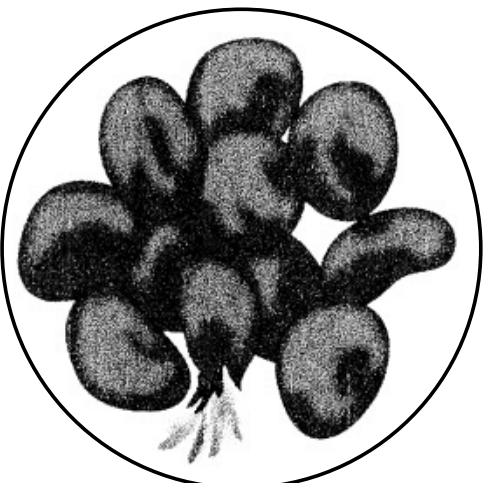

A

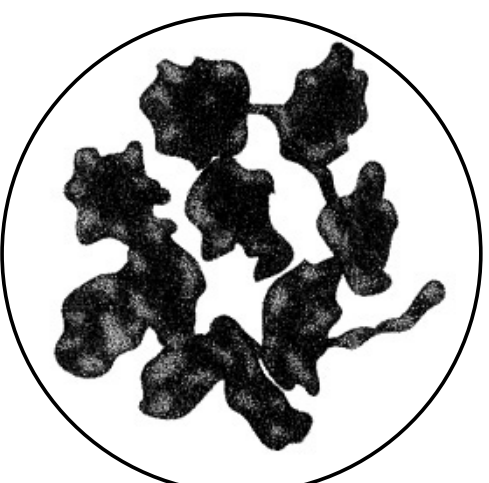

B

77 Identify which group of cells, A or B, had most likely been placed in distilled water. Support your answer. [1]

Base your answer to question 78 on the information below and on your knowledge of biology.

A student placed artificial cells, each containing a 25% sugar solution, into three different beakers containing sugar solution which varied in concentration from 0% to 25%. The setups are shown below.

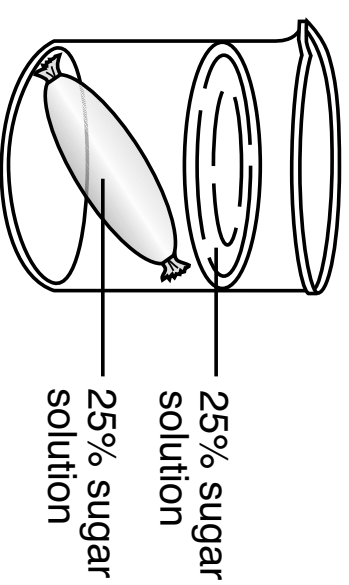
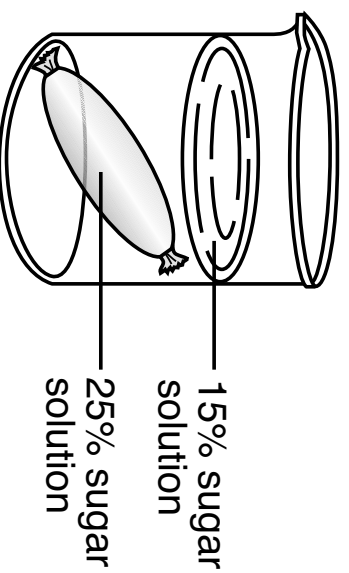
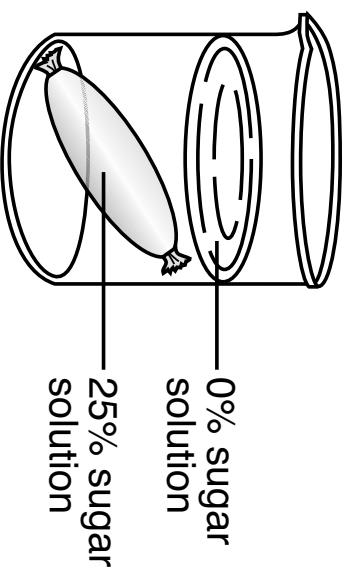

78 The student collected data on the mass of each artificial cell. The student predicted that the cell in the beaker with 25% sugar solution would have the greatest change in mass after 24 hours. Would his prediction be correct? Support your answer. [1]

79 Identify *one* waste product that is more effectively removed from muscle cells as a result of increased pulse rate. [1]

Base your answers to questions 80 and 81 on the information and chart below and on your knowledge of biology.

The chart represents the results of gel electrophoresis of DNA from an unknown individual and four known individuals.

Gel Electrophoresis Results of DNA From Five Individuals

| Unknown Individual | Individual A | Individual B | Individual C | Individual D |
|--------------------|--------------|--------------|--------------|--------------|
| — | — | — — — | — | — |
| — | — | — — — | — | — |
| — — — | — | — | — | — — — |
| — — | — | — — | — | — — |

80 Identify the unknown individual as *A*, *B*, *C*, or *D* by comparing the gel electrophoresis results. Support your answer. [1]

Note: The answer to question 81 should be recorded on your separate answer sheet.

81 Before conducting an electrophoresis procedure, enzymes are added to DNA in order to

- (1) convert the DNA into gel
 - (2) cut the DNA into fragments
 - (3) remove smaller DNA fragments from the samples
 - (4) synthesize larger fragments of DNA
-

GO RIGHT ON TO THE NEXT PAGE →

Note: The answer to question 82 should be recorded on your separate answer sheet.

82 Variations in the flying speed of a finch population are represented in the graph below. The top flying speed of a predator of these finches is also indicated on the graph.

Flying Speeds of Finches

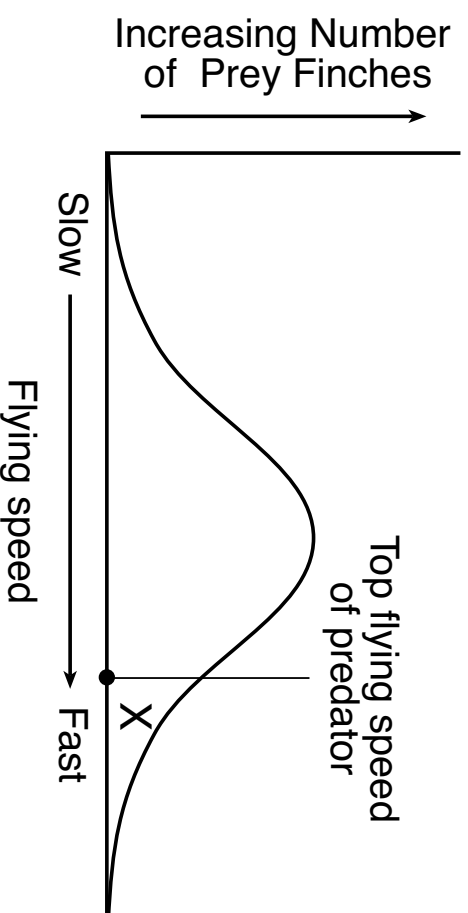

When describing finches with flying speeds in the region indicated by the X on the graph, it would be accurate to say that these individuals are more likely to

- (1) reproduce and increase the frequency of fast finches in the population
- (2) survive and undergo mutations that increase their flying speeds
- (3) require less food than the slower finches in the population
- (4) produce offspring that fly at average speeds

Base your answer to question 83 on the information below and on your knowledge of biology.

RNA Codons and the Amino Acids for Which They Code

| | | | | | | | |
|-------------------|--------------------|--------------------------|-------------------|--------------------------|------------------------------------|--------------------------|----------------------------------|
| AUU AUC AUA | } ILE (Isoleucine) | ACU ACC ACA ACG | } THR (Threonine) | AAU AAC AAA AAG | } ASN (Asparagine) LYS (Lysine) | AGU AGC AAA AGG | } SER (Serine) ARG (Arginine) |
|-------------------|--------------------|--------------------------|-------------------|--------------------------|------------------------------------|--------------------------|----------------------------------|

83 If a sequence of bases in DNA changes from TGA to TGG, would it result in a new inheritable trait? Support your answer. [1]

Base your answers to questions 84 and 85 on the information below and on your knowledge of biology.

The diagram below represents a recently developed evolutionary tree for some species of birds. The new tree diagram is based on the analysis of data collected from 169 bird species and includes a change in the placement of flamingos. The flamingos are now grouped with the grebes and pigeons instead of with egrets and penguins.

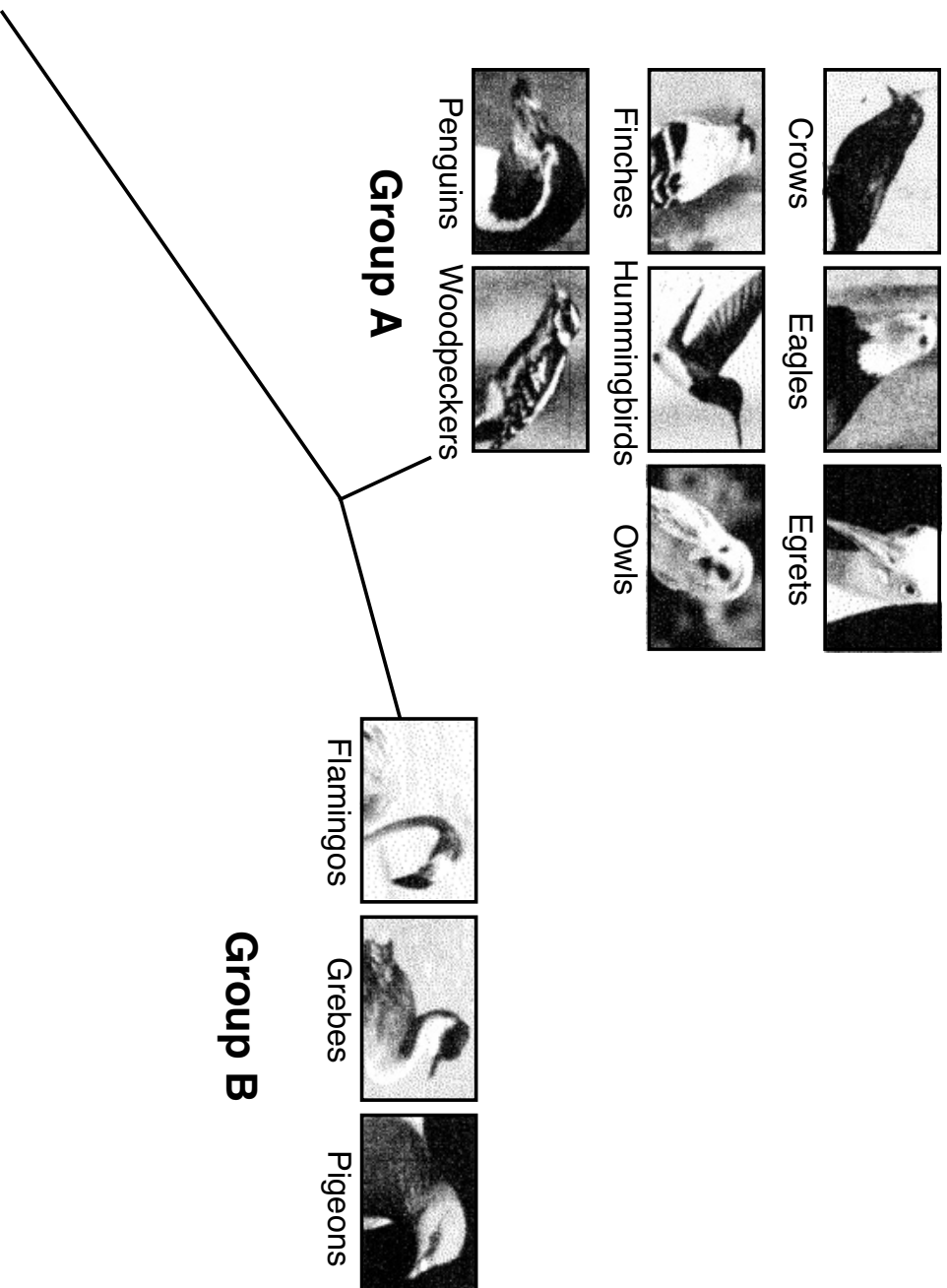

Source : Science News 1/10/15

84 Identify *one* type of molecular evidence that was most likely used to develop this new tree. Explain how this evidence would support the new position of the Flamingos. [1]

85 Based on the photos on the previous page, select *two* bird species, one from Group A and one from Group B, and state *one* reason why researchers may have originally thought these two species should be on the same branch of the tree. [1]

Bird species from Group A: _____

Bird species from Group B: _____
